

## ECARO-25™ AGENT STORAGE CONTAINERS

### DESCRIPTION

Fike Series 70 Clean Agent Containers are used in fire extinguishing systems to store the Clean Agent until a fire develops and the agent must be released. The Clean Agent is retained in the container by a valve assembly which contains a fast-acting rupture disc. The disc will be ruptured, and the Clean Agent released, through the operation of an actuator by an electric signal that is automatically or manually controlled. The valve is available in three sizes: 1" (25mm), 2 1/2" (65mm) and 3" (80mm). The 1" (25mm) valve is used on the 20 (8.5 L), 35 (15 L), 60 (27 L), and 100 pound (44 L) containers; the 2 1/2" (65mm) valve is used on the 125i (51 L) and 215i pound (90 L) containers; the 3" (80mm) valve is used on the 215 (88 L), 375 (153 L), 650 (267 L) and 1000 pound (423 L) containers. After a discharge, the valve is field reconditioned by simply replacing three components.

Fike Series 70 Clean Agent Containers have passed extensive testing by Factory Mutual and Underwriters Laboratory and are used in installations where 8 to 836 pounds (3.5 to 379.5 kg) of HFC-125 agent is required. To eliminate the need for multiple containers, or using more Clean Agent than necessary, these containers can be filled in 1 pound (0.5 kg) increments to their maximum capacity.

Each container for ECARO-25 Clean Agent Systems is super pressurized with dry nitrogen to 360 psig (25 bar), at 70° F (21° C), to provide a quick and effective discharge in 10 seconds or less.

Fike Series 70 Clean Agent Containers are supplied with a pressure gauge that permits a quick, visual, inspection of container pressure. Optional items include a Liquid Level Indicator, and a Low Pressure Supervisory Switch. The Liquid Level Indicator provides the convenience of determining the container's agent weight without removing it from its installed location. The Low Pressure Supervisory Switch provides constant monitoring of the container's internal pressure. In the event of a decrease in container internal pressure from 360 psig to 288 psig (24.8 bar to 18.8 bar), the Supervisory Switch normally opened/closed contacts will close/open. This will cause a supervisory trouble alarm at the system control panel.

Fike Series 70 Clean Agent Containers are available for installation in the upright, inverted or horizontal positions, depending upon the user's particular needs and the type and size container specified. The mounting location of the container is quite flexible. It can be mounted at the exact point of discharge or at a remote location by adding distribution piping from the container to the nozzle system. (Refer to the Fike Design, Installation and Maintenance Manual - P/N 06-285).

The operating temperature range is +32° to +120°F (0° to 49.0°C) in any installation. If the Clean Agent reaches an internal temperature range of 130° to 150°F (49.9° to 65.5°), it will create a sufficient internal pressure to burst the rupture disc and release the Clean Agent through the piping network.



### APPROVALS

- UL Listed - Ex 4623
- FM Approved - OY4ABAF (HFC-227ea)

Form No. C.1.41.01-6

## RELIABILITY

Fike Series 70 Clean Agent Containers are manufactured in strict accordance with Department of Transportation (D.O.T.) regulations. The Fike Series 70 Clean Agent Containers have successfully passed testing by Factory Mutual and Underwriters Laboratories, Inc. Before leaving the factory, each container must pass extensive leakage testing, and pressure testing to 1000 psig (69 bar). The containers are constructed from carbon steel alloys and painted with a durable, baked enamel finish.

## INSTALLATION

Fike Series 70 Clean Agent Containers are supplied with a mounting bracket that is designed to provide the most effective and versatile installation for that particular container. The 20, 35 and 60 pound (8, 15 and 27 L) container brackets employ two U-bolts for securing the container to the bracket. The 125i and 215i pound (51 and 90 L) containers utilize an “L” shaped bracket for direct wall mounting or, with an optional floor mounting kit, can be mounted on a floor in the “valve down” position. The 100 (44) and 215 (87) through 1000 pound (423 L) containers are supplied with one U-shaped mounting strap for mounting to a wall or other secure surface.

## CLEAN AGENT STORAGE CONTAINER DATA - U.S. STANDARD

Fike P/N	Size (lbs)	Valve (in)	Empty Wt (lbs)	HFC-125 Agent Fill Range (lbs)	Valve Position	D.O.T. Regulation
70-098	20	1	21	8-16	Horizontal or Upright	4BW500
70-089	35	1	31	14-30	Horizontal or Upright	4BW 500
70-152	60	1	52	25-54	Horizontal or Upright	4BW500
70-153	100	1	74	39-87	Upright	4BW500
70-041	125i	2 1/2	145	46-101	Inverted	4BA500
70-077	215i	2 1/2	200	80-178	Inverted	4BA500
70-154	215	3	157	78-173	Upright	4BW500
70-155	375	3	224	136-302	Upright	4BW500
70-156	650	3	385	236-528	Upright	4BW500
70-157	1000	3	540	374-836	Upright	4BW500

---

CLEAN AGENT STORAGE CONTAINER DATA - METRIC

	Size (L)	Valve (MM)	Empty Wt (KG)	HFC-125 Agent Fill Range (KG)	Valve Position	D.O.T. Regulation
70-098	8.5	25	6.4	3.5-7.5	Horizontal or Upright	4BW500
70-089	15	25	9.5	6.5-13.5	Horizontal or Upright	4BW500
70-152	27	25	14.1	11.5-24.5	Horizontal or Upright	4BW500
70-153	44	25	23.6	18.0-39.0	Upright	4BW500
70-041	51	65	65.8	21.0-46.0	Inverted	4BA500
70-077	90	65	90.7	36.5-81.0	Inverted	4BA500
70-154	88	80	71.2	35.5-78.5	Upright	4BW500
70-155	153	80	101.6	61.5-137.0	Upright	4BW500
70-156	267	80	174.6	107.0-239.5	Upright	4BW500
70-157	423	80	244.9	169.5-379.5	Upright	4BW500

CLEAN AGENT STORAGE CONTAINER DIMENSIONS

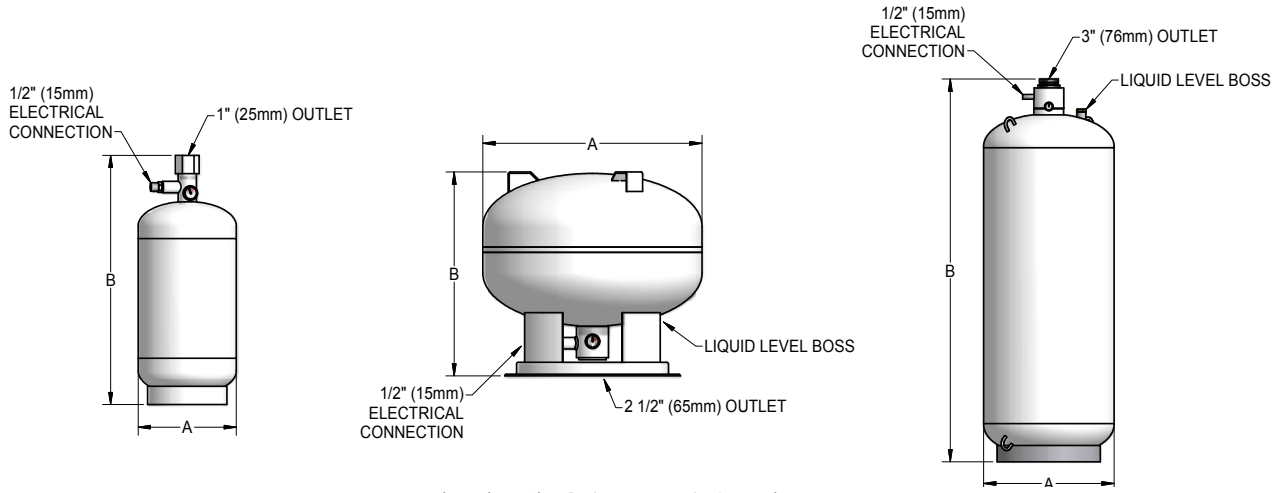

20 - 100LB (8.5 to 44L) Container  
LLi on 100LB (44L) only

125i and 215i LB (51 to 90L) Container

215 - 1000LB (88-423L) Container

U.S. Sizes and Dimensions										
Size-LB	20	35	60	100	125i	215i	215	375	650	1000
A (in)	7.25	7.25	10.75	10.75	20.00	24.00	20.00	20.00	24.00	24.00
B (in)	21.50	32.50	28.00	38.75	20.25	23.75	28.87	42.50	48.75	70.00
Metric Sizes and Dimensions										
Size-L	8.5	15	27	44	51	90	88	153	267	423
A (mm)	184	184	273	273	508	610	508	508	610	610
B (mm)	546	826	711	984	515	605	733	1080	1237	1778

## ARCHITECT AND ENGINEERING SPECIFICATIONS

The Clean Agent shall be stored in Fike Series 70 Clean Agent Storage Containers. The containers shall be capable of being filled, in one-pound (0.5kg) increments, to their listed maximum capacity. The Clean Agent container shall be activated by a signal from the control panel which is processed by the Agent Release Module. This module shall store the power required to operate the actuator. The valve shall contain a scored, non-fragmenting, rupture disc to provide an immediate, total discharge of all the agent. HFC-125 Clean Agent is stored in the container as a liquid, having a natural vapor pressure of 200 psig at 77°F (13 barg at 25°C). To aid in discharge, the container shall be super-pressurized to 360 psig at 70°F (25 bar at 21°C) with dry nitrogen. Agent discharge shall be completed in 10 seconds or less.

Clean Agent Storage Containers shall be actuated by an electrical signal that is automatically or manually controlled. Normal operating temperature shall be +32° to +120°F (0° to 49°C) in any installation.

Clean Agent Storage Containers shall be equipped with a pressure gauge to display internal pressure. This gauge shall be an integral part of the container and color coded for fast referencing of pressure readings. A Low Pressure Supervisory Switch shall be made available, as an option. A decrease in internal container pressure from 360 to 288 psig (24.8 to 18.8 bar) shall cause the normally opened/closed Supervisory Switch contacts to close/open, indicating a trouble or supervisory condition, at the control panel.

Clean Agent Storage Containers shall be fastened to a wall, or other secure surface, using an optional mounting bracket that is designed for the most effective and versatile installation of each container.



Copyright © Fike Corporation All Rights Reserved.

Form No. C.1.41.01-6 January, 2009 Specifications are subject to change without notice.

---