

Fenwal Engineered Fire Suppression System

Designed for use with 3M™ Novec™ 1230 Fire Protection Fluid

Bottom Discharge Agent Storage Container

F-44-1920-1



A UTC Fire & Security Company

P/N: 44-19204X-00X

FEATURES

- 350, 560, and 850-lb. Capacities
- Electric Initiator Actuation
- 3-inch Discharge Valve
- Optional Liquid Level Indicator
- Standard Low Pressure Supervisory Pressure Switch
- UL Listed
- FM Approved

DESCRIPTION

Fenwal Engineered Fire Suppression System Designed for use with 3M™ Novec™ 1230 Fire Protection Fluid Bottom Discharge Agent Storage Containers store Novec 1230 fluid super-pressurized with dry nitrogen to 360 psig (70°F). They are painted red and are equipped with a 3-inch burst disc type discharge valve, a replaceable initiator well, a screen assembly, pressure gauge, supervisory pressure switch with cable assembly, fill port, overpressure relief valve, safety cap, liquid level measuring device (optional) and lifting lugs. A 3-inch Flex Hose (P/N 29-117134-002) is available to facilitate piping connections. Initiator assemblies P/N 44-191001-001 must be ordered for each container.

OPERATION

The agent storage container discharges when the initiator is actuated, causing the burst-disc valve to rupture.

INSTALLATION

The container is installed in a vertical position with the valve assembly pointing up. Interconnection for discharge piping is 3-inch NPT. A 3-inch flex hose is available to facilitate connection between the container and discharge piping. A 3-inch, 300-lb. malleable-iron threaded pipe union manufactured per ANSI B16.39 is required to mate the tank discharge port to the flex-hose assembly.

The container is secured in place by one set of mounting brackets (P/N 29-232334-00X) which are bolted together around the container and affixed to a solid wall or a strut assembly. Two 1/2-inch diameter bolts are required to secure the mounting brackets to a vertical surface and two 1/2-inch diameter 9-inch long threaded rods are needed to hold the two mounting brackets together.

After the container is securely mounted, it is connected to discharge piping per the system drawings. The initiator assembly is then installed.



MAINTENANCE

According to NFPA standards the following inspection and/or maintenance procedure must be scheduled as listed below and performed upon the occurrence of any event which might affect the reliability of the system.

QUARTERLY INSPECTION

1. Check the pressure gauges of each agent storage container. If the pressure is less than 325 PSIG at 70°F (22.9 kg/cm² at 21°C), the container should be removed and carefully inspected by certified personnel. It should then be reconditioned, recharged or replaced as its condition indicates. Pressure varies with temperature.
2. Check all component supporting hardware and tighten, repair, or replace as required.
3. Visually check all components for evidence of physical abuse and take whatever action is required. Replace any component if at all in doubt of its ability to perform properly.

SEMI-ANNUAL INSPECTION

Qualified personnel are to determine the amount of agent in all containers. The optional liquid level indicator may be used to measure agent supply and compare it to the original net weight which is marked on the container label. If the measured net weight is less than 95% of the original charged net weight the container should be tested for leakage, recharged and reinstalled.

Inspect all piping, fittings and nozzles for looseness, dirt or other damage. All outlet piping must be clean and free of dirt, chips, fillings and other foreign material that may cause the system to become inoperative or ineffective at the time of discharge.

RECONDITIONING

After a system has been discharged, it is recommended that the local authorized Fenwal distributor be contacted to recondition the system.

The reconditioning kit for these containers is P/N 31-193017-001. The initiator, not included, is ordered separately.

ORDERING INFORMATION

KEY TO PART NUMBERS

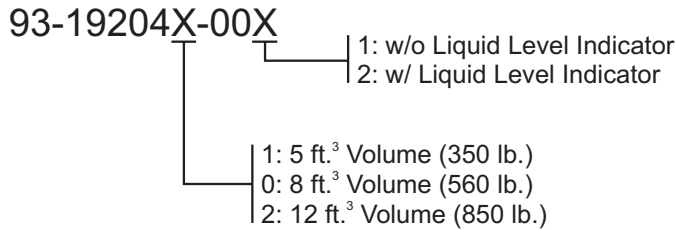

ACCESSORIES

	44-192041-00X	44-192040-00X	44-192042-00X
Bracket (Black) (Two Required per Container)	29-232334-004	29-232334-002	29-232334-000
LLI Tape Assembly	283894		
LLI Rod Assembly (Pre-Sept. 99)	31-194099-012		N/A

SPECIFICATIONS

AGENT STORAGE CONTAINERS

	44-192041-00X	44-192040-00X	44-192042-00X
Fill Range (lb. without LLI)	178 - 354	184 - 567	427 - 854
Fill Range (lb. with LLI)	178 - 354	184 - 567	427 - 854
Height (in.)	57	58-1/2	60-1/2
Diameter (in.)	16	20	24
Internal Volume (ft. ³)	5	8	12
Empty Weight (lbs.)	250	350	480
Maximum Static Load	600	910	1330
Temperature Range	0 to 130°F (-17.7 to 54°C)		
Safety Release Burst Range	850 to 1000 PSIG		
Construction Specification	DOT-4BW500		

SUPERVISORY PRESSURE SWITCHES

	06-115549-003	06-115549-002
Shipped/Optional	Shipped with Containers	Optional
Contact Rating	2 Amps @ 24 Vdc	
Operation	Open Under Pressure (Contacts close at: 200, ±15 PSIG)	Closed Under Pressure (Contacts close at: 200, ±15 PSIG)

DIMENSIONAL INFORMATION

TANK AND BRACKET DIMENSIONS

	44-192041-00X	44-192040-00X	44-192042-00X
	5 ft. ³ (350 lb.)	8 ft. ³ (560 lb.)	12 ft. ³ (850 lb.)
Dimension (in.)			
A	57	58-1/2	62-1/4
B	16-1/2	16-1/2	17
C	16	20	24
D	7-1/8		
E	7-7/8		
F	4-3/16		
G	5-5/8	7-1/4	8-3/4
H	19-1/4	22	26-5/8
I	17-3/4	23-1/2	28-7/8
J	7-1/4	9-1/2	11-1/2

BRACKET OUTLINE

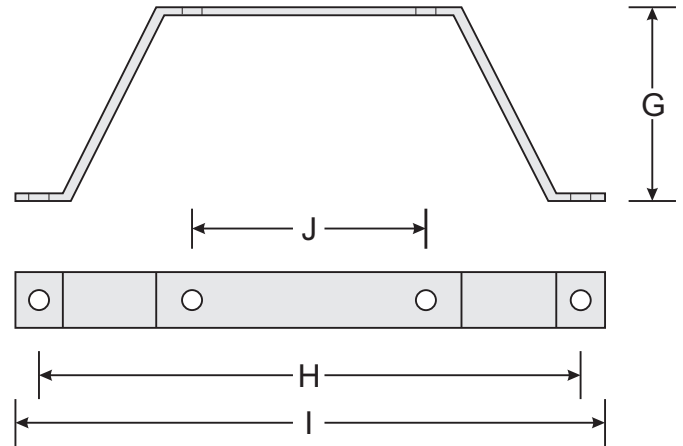

AGENT STORAGE CONTAINER OUTLINE

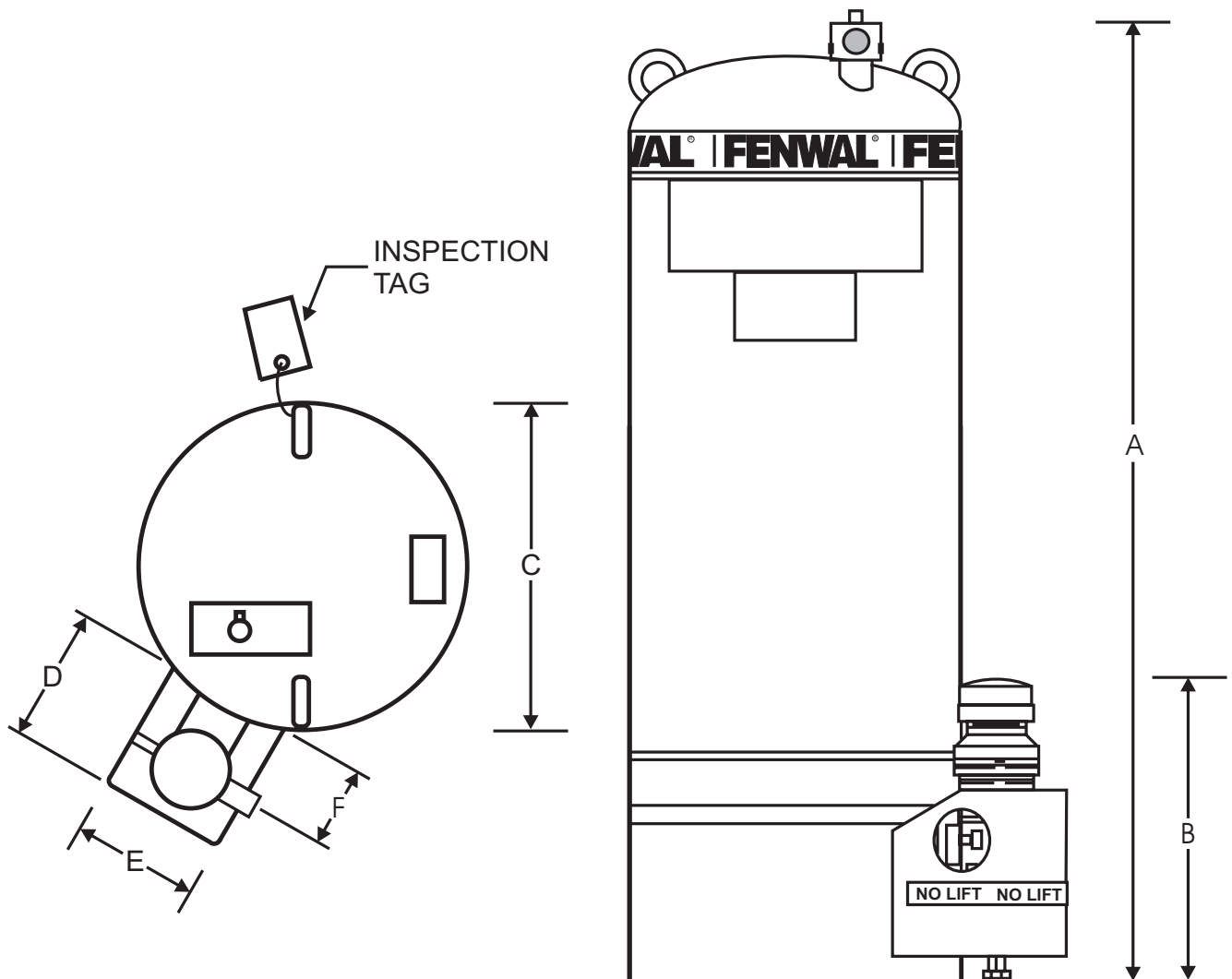

ARCHITECTURAL AND ENGINEERING SPECIFICATIONS

The Novec 1230 fluid shall be stored in vertically mounted cylindrical containers with a 3-inch burst disc type discharge valve. Containers shall be super-pressurized with dry nitrogen to 360 PSIG at 70°F. This container shall be Fenwal P/N 44-19204X-00X.

Containers shall be UL Listed and FM Approved.

Each agent storage container shall have a fill range of 178-354, 284-567, or 427-854 lb. and be of a construction that complies with DOT-4BW500.

The agent storage container shall incorporate lifting lugs, overpressure relief, 3-inch burst-disk type discharge valve, fill port, cable assembly, pressure gauge, supervisory pressure switch, liquid-level indicator (optional), and a safety cap. Electrical device's connecting leads shall be completely supervised.

A compatible flex hose shall be available to facilitate installation and connection to discharge piping.

The container shall be secured in place by two opposing steel mounting brackets. These brackets shall be Fenwal P/N 29-232334-00X.

Fenwal is a registered trademark of Kidde-Fenwal, Inc.
3M and Novec are trademarks of 3M.
All other trademarks are property of their respective owners.

This literature is provided for informational purposes only. KIDDE-FENWAL, INC. assumes no responsibility for the product's suitability for a particular application. The product must be properly applied to work correctly.
If you need more information on this product, or if you have a particular problem or question, contact KIDDE-FENWAL, INC., Ashland, MA 01721. Telephone: (508) 881-2000.



A UTC Fire & Security Company

400 Main Street
Ashland, MA 01721
Ph: 508.881.2000
Fax: 508.881.8920
www.fenwalfire.com