

# Fenwal Engineered Fire Suppression System

Effective March 2005

F-44-7145

Designed for use with 3M™ Novec™ 1230 Fire Protection Fluid

## Cylinder Recharge Adapters Component Sheet

# FENWAL®

P/N: 878757 and 878758

### FEATURES

- For use with UL Listed, ULC Listed and FM Approved Systems

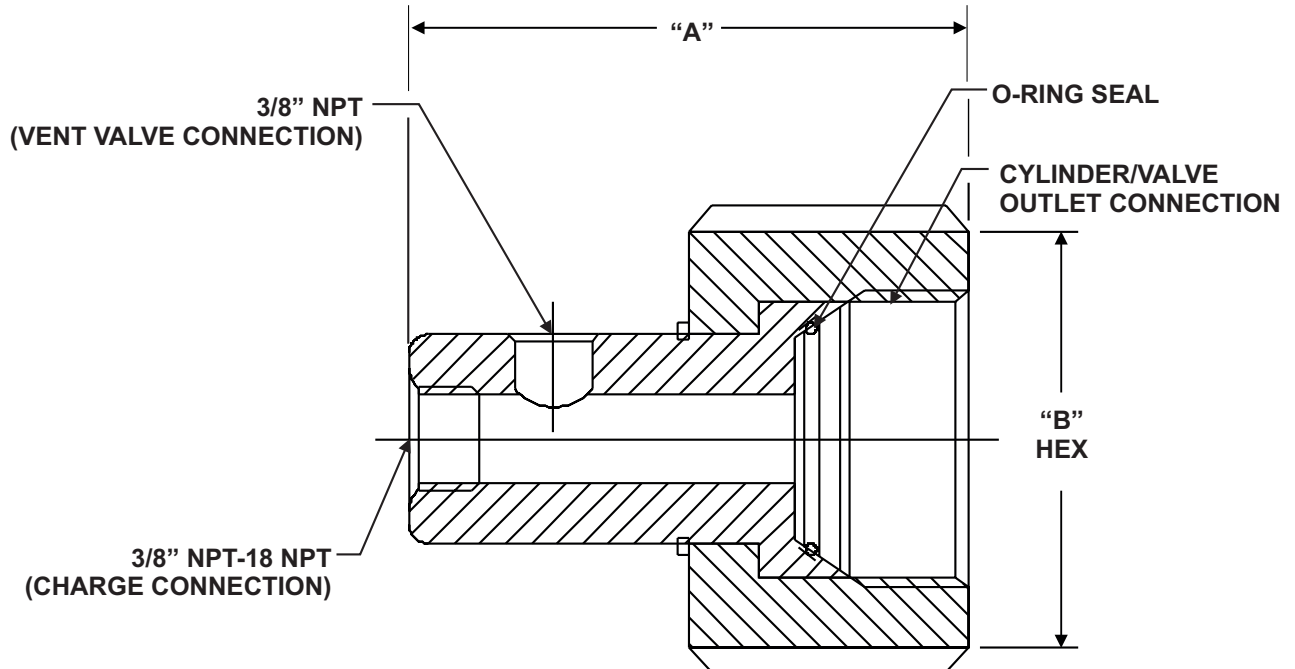

### MATERIALS

- Zinc Plated Steel

### ORDERING INFORMATION

Part Number	Cylinder Size	Dimensions	
		A	B
878757	10 to 125 lb.	3.22 in. ( 82 mm)	2.50 in. (64 mm)
878758	200 and 350 lb.	4.06 in. (103 mm)	3.25 in. (83 mm)

**Note:** Fill adapter not required for cylinders that use a 3" valve (600 and 900 lb. cylinders).

Fenwal is a registered trademark of Kidde-Fenwal, Inc.  
3M and Novec are trademarks of 3M.  
All other trademarks are property of their respective owners.



## FENWAL® Protection Systems

KIDDE-FENWAL, INC.  
400 MAIN STREET, ASHLAND, MA 01721  
TEL: (508)881-2000 FAX: (508) 881-8920  
www.fenwalfire.com

This literature is provided for informational purposes only. KIDDE-FENWAL, INC. assumes no responsibility for the product's suitability for a particular application. The product must be properly applied to perform as described herein.  
If you need more information on this product, or if you have a question, contact KIDDE-FENWAL, INC., Ashland, MA 01721; Telephone (508) 881-2000