

Fenwal Engineered Fire Suppression System

Effective March 2005

F-44-8140

Designed for use with 3M™ Novec™ 1230 Fire Protection Fluid

Cylinder Wall Brackets Component Sheet

FENWAL®

P/N: 48648X

FEATURES

- For use with UL Listed, ULC Listed and FM Approved Systems

MATERIALS

- Steel, Zinc Painted SAE 1010

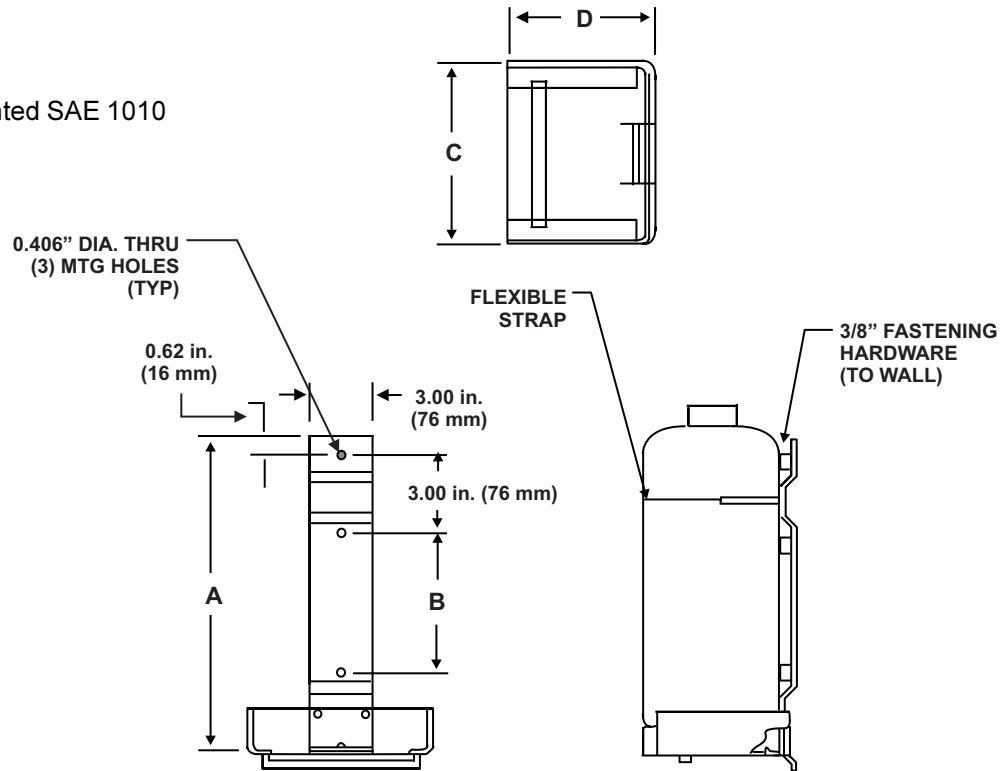

Part Number	Cylinder Cap	Dimension A	Dimension B	Dimension C	Dimension D
486485	10 lb.	8.62 in. (219 mm)	1.56 in. (40 mm)	7.68 in. (195 mm)	5.75 in. (146 mm)
486486	20 lb.	14.37 in. (365 mm)	7.31 in. (186 mm)	7.68 in. (195 mm)	5.75 in. (146 mm)
486487	40 lb.	13.12 in. (333 mm)	5.94 in. (151 mm)	9.75 in. (248 mm)	6.75 in. (172 mm)
486488	70 lb.	19.62 in. (498 mm)	12.44 in. (316 mm)	9.75 in. (248 mm)	6.75 in. (172 mm)

Fenwal is a registered trademark of Kidde-Fenwal, Inc.
3M and Novec are trademarks of 3M.
All other trademarks are property of their respective owners.



FENWAL® Protection Systems

KIDDE-FENWAL, INC.
400 MAIN STREET, ASHLAND, MA 01721
TEL: (508)881-2000 FAX: (508) 881-8920
www.fenwalfire.com

This literature is provided for informational purposes only. KIDDE-FENWAL, INC. assumes no responsibility for the product's suitability for a particular application. The product must be properly applied to perform as described herein.
If you need more information on this product, or if you have a question, contact KIDDE-FENWAL, INC., Ashland, MA 01721; Telephone (508) 881-2000

F-44-8140

©2005 Kidde-Fenwal, Inc. Printed in U.S.A.