



## Discharge Nozzle – Cone Type

### Description

The cone nozzle is used primarily for local application and also listed and approved for use as a total flooding nozzle. The nozzle insert is stainless steel and the body is sheet steel. The nozzle is available in orifice sizes ranging from 3 through 11. The discharge rate of the nozzle depends on the orifice size and nozzle pressure. The area covered in local application is dependent upon the discharge rate and the height above the surface being protected.

Height range: 42 to 108 in. (107 to 274 cm). Discharge rate: 21 to 132 lbs. per minute (10 to 60 kg per minute). See carbon dioxide design manual for area coverage and required flow rates.

The nozzle is painted red with chrome or nickel plating available as an option.

Component	Material	Thread Size/Type	Orifice Size	Approvals
Cone nozzle	Shell: Steel Insert: Stainless Steel	1/2 in. NPT Female	3 through 11	UL (EX-2968) FM Approved

Shipping Assembly Part No.	Description	Orifice Code
426105	Cone nozzle	3 – 11

NOTE: When ordering, specify orifice code required: Example – Part No.426105 – 3.5.

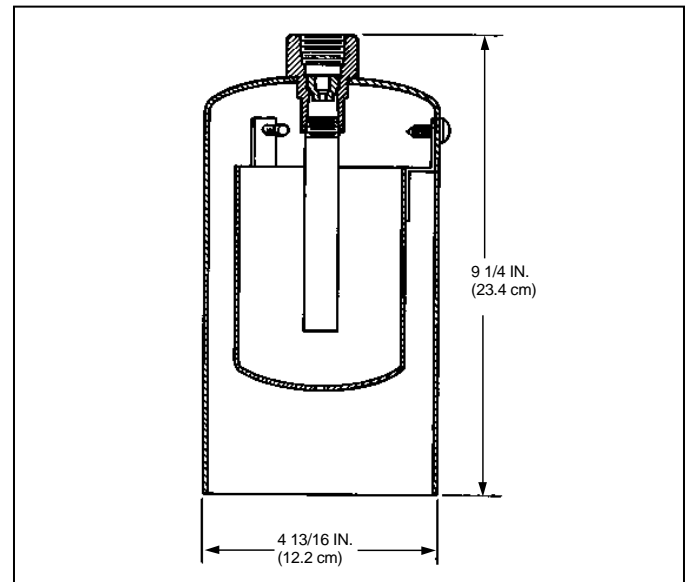

ANSUL is a registered trademark.