

CO₂ Component Description

Assembly of Grooved Nut Discharge Head to Type "I" Cylinder

Effective: April 2002
K-81-1071

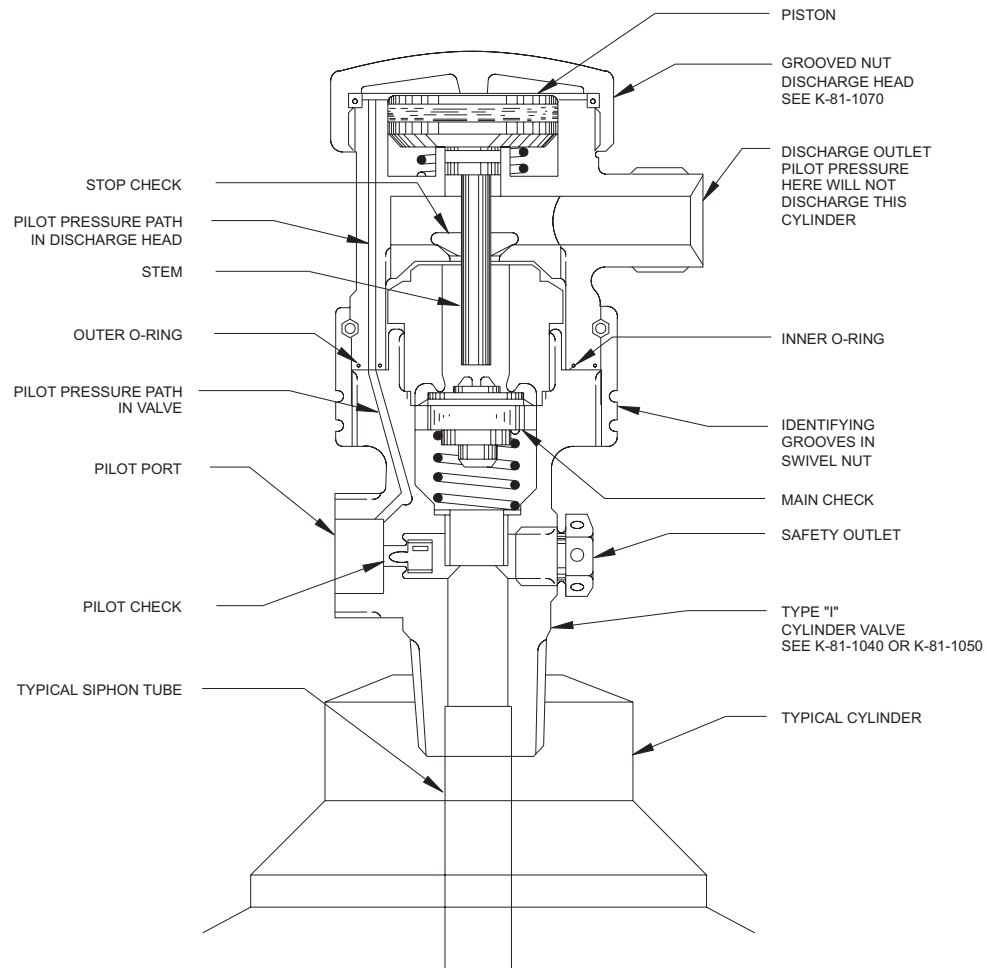

WARNING

Never connect discharge head to cylinder valve without flex loop attached to discharge outlet and the cylinder properly secured and connected to system piping. Arrangement as shown is for illustration purposes only.

PRESSURE RATING:
2400 PSIG TO 2800 PSIG (165 BAR-193 BAR)

This literature is provided for informational purposes only. KIDDE-FENWAL, INC. assumes no responsibility for the product's suitability for a particular application. The product must be properly applied to work correctly. If you need more information on this product, or if you have a particular problem or question, contact KIDDE-FENWAL INC., Ashland, MA 01721. Telephone: (508) 881-2000