

Grooved Nut Discharge Head

P/N: 872442

F-93-101

FENWAL®

FEATURES

- Can Only be Actuated with the use of a Control Head
- For Use with Single Nitrogen Driver Systems Only (225 lb. and 395 lb. Systems)
- UL Listed
- FM Approved

DESCRIPTION

Each nitrogen driver cylinder and valve assembly must be equipped with a discharge head at installation to actuate the cylinder valve. The discharge head is assembled to the top of the cylinder valve and contains a spring-loaded piston which, when actuated by nitrogen pressure, is designed to depress the main check in the valve and transfer the contents of nitrogen into the agent cylinder. The transfer outlet is designed to mate with the swivel adapter on the 1" flexible transfer hose (P/N 06-118207-00X). The discharge head also contains an integral stop check which, in the event that a cylinder is removed from the Fenwal Phoenix assembly, automatically prevents the loss of nitrogen during the system transfer. The grooved-nut discharge head only allows the cylinder to be actuated when a control head releases pilot pressure. Pressure entering the outlet will not actuate the cylinder.

INSTALLATION

⚠ WARNING

The agent storage cylinder must be permanently connected to the system piping. Never attach the discharge head to the cylinder valves until the cylinders are secured in brackets or racking and the hose is attached to the agent cylinder. Under no circumstances is the discharge head to remain attached to the cylinder valve after removal from service or during shipment, handling, storage or filling. In the event of an inadvertent discharge, failure to follow these instructions could result in death, serious bodily injury and/or property damage.

1. Wipe off cylinder valve sealing surface.
2. Verify that the O-rings are installed in the mating surface grooves at the bottom of the swivel nut cavity. O-rings must be free of dirt or other contaminants. The O-rings have been lightly greased at the factory and should not require further greasing.
3. Make sure the pilot orifice located between the inner and outer O-ring is unobstructed.



4. Make sure the discharge port is clean and unobstructed.
5. Install the discharge head on the cylinder valve. Tighten securely.

Note: The grooved nut discharge head is not intended for use with the 675 lb. and 1010 lb. systems.

MAINTENANCE

MONTHLY:

Inspect nitrogen driver discharge head for cracks, corrosion, grime, etc. Ensure that the discharge head is tightly secured to the nitrogen cylinder valve and connected to the agent cylinder with the 1" nitrogen transfer hose. If any defects are found during the monthly inspection, immediately contact a Fenwal Distributor to service the systems.

SPECIFICATIONS

MATERIALS

- **Body:** Brass
- **O-rings:** Rubber
- **Spring:** Stainless Steel
- **Stop Check:** Brass
- **Weight:** 4.0 lb. (1.8 kg)

ORDERING INFORMATION

Part Number	Description
872442	Grooved Nut Discharge Head

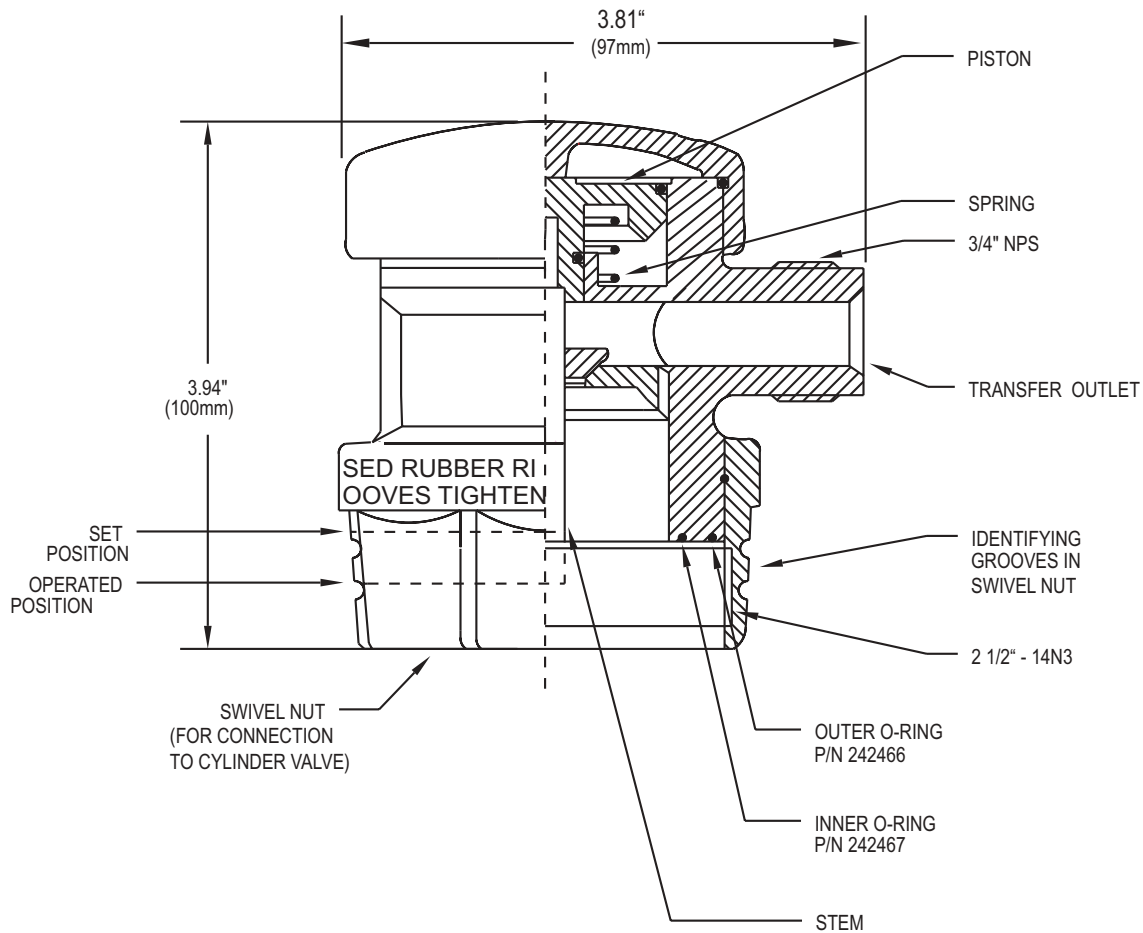

Figure 1. Discharge Head, Grooved Nut



FENWAL[®]
Protection Systems

KIDDE-FENWAL, INC.
 400 MAIN STREET, ASHLAND, MA 01721
 TEL: (508)881-2000 FAX: (508) 881-8920
 www.fenwalfire.com

These instructions do not purport to cover all the details or variations in the equipment described, nor do they provide for every possible contingency to be met in connection with installation, operation and maintenance. All specifications subject to change without notice. Should further information be desired or should particular problems arise which are not covered sufficiently for the purchaser's purposes, the matter should be referred to KIDDE-FENWAL, INC., Ashland, MA 01721.