

# AUTOPULSE® IQ-318 INTELLIGENT ADDRESSABLE FIRE ALARM SYSTEM

Data/Specifications



## GENERAL

The AUTOPULSE® IQ-318 intelligent Fire Alarm Control Panel is part of the AUTOPULSE Series of Fire Alarm Controls from ANSUL®.

Designed with modularity and for ease of system planning, the AUTOPULSE IQ-318 can be configured with just a few devices for small building applications, or for a large campus or high-rise application. Simply add additional peripheral equipment to suit the application.

## FEATURES

- Listed to UL Standard 864, 9th edition.
- One isolated intelligent Signaling Line Circuit (SLC) Style 4, 6 or 7.
- Up to 159 detectors (any mix of ion, photo, thermal, or multi-sensor) and 159 modules (NO manual stations, two wire smoke, notification, or relay). 318 devices maximum.
- Standard 80-character display.
- 6.0 amp power supply with four Class A/B built-in Notification Appliance Circuits (NAC). Selectable System Sensor, Wheelock, or Gentex strobe synchronization.
- Built-in Alarm, Trouble, and Supervisory relays.
- VeriFire® Tools offline program option. Sort Maintenance Reports by compensation value (dirty detector), peak alarm value, or address.
- Autoprogramming and Walk Test reports.
- Optional universal 318-point DACT.
- 80-character remote annunciators (up to 32).
- EIA-485 annunciators, including custom graphics.
- Printer interface (80-column and 40-column printers).
- History file with 800-event capacity in nonvolatile memory, plus separate 200-event alarm-only file.
- Alarm Verification selection per point, with tally.
- Autoprogramming and Walk Test reports.
- Positive Alarm Sequence (PAS) Presignal.
- Silence inhibit and Auto Silence timer options.
- March time / temporal / California two-stage coding / strobe synchronization.
- Field-programmable on panel or on PC, with VeriFire Tools program check, compare, simulate.
- Full QWERTY keypad.
- Charger for up to 90 hours of standby power.
- Non-alarm points for lower priority functions.
- Remote ACK/Signal Silence/System Reset/Drill via monitor modules.
- Automatic time control functions, with holiday exceptions.
- Surface Mount Technology (SMT) electronics.
- Extensive, built-in transient protection.
- Powerful Boolean logic equations.
- **FlashScan® intelligent features:**
  - Poll 318 devices in less than two seconds.
  - Activate up to 159 outputs in less than five seconds.
  - Multicolor LEDs blink device address during Walk Test.
  - Fully digital, high-precision protocol (U.S. Patent 5,539,389).
  - Manual sensitivity adjustment — nine levels.
  - Pre-alarm ONYX intelligent sensing — nine levels.
  - Day/Night automatic sensitivity adjustment.
  - Sensitivity windows:



007704

**Ion** – 0.5 to 2.5%/foot obscuration.

**Photo** – 0.5 to 2.35%/foot obscuration.

**Laser (VIEW®)** – 0.02 to 2.0%/foot obscuration.

**Acclimate Plus™** – 0.5 to 4.0%/foot obscuration.

**HARSH™** – 0.5 to 2.35%/foot obscuration.

- Drift compensation (U.S. Patent 5,764,142).
  - Degraded mode — in the unlikely event that the CPU-318 micro-processor fails, FlashScan detectors revert to degraded operation and can activate the CPU-318 NAC circuits and alarm relay. Each of the four built-in panel circuits includes a Disable/Enable switch for this feature.
  - Multi-detector algorithm involves nearby detectors in alarm decision (U.S. Patent 5,627,515).
  - Automatic detector sensitivity testing.
  - Maintenance alert (two levels).
  - Self-optimizing pre-alarm.
- **VIEW (Very Intelligent Early Warning) smoke detection technology:**
- Revolutionary spot laser design.
  - Advanced intelligent sensing algorithms differentiate between smoke and non-smoke signals (U.S. Patent 5,831,524).
  - Addressable operation pinpoints the fire location.
  - No moving parts to fail or filters to change.
  - Early warning performance comparable to the best aspiration systems at a fraction of the lifetime cost.
- **Acclimate Plus low-profile intelligent multi-sensor:**
- Detector automatically adjusts sensitivity levels without operator intervention or programming. Sensitivity increases with heat.
  - Microprocessor-based technology; combination photo and thermal technology.
  - FlashScan or classic mode compatible with NFS2-636, NFS-318.
  - Low-temperature warning signal at 40 °F ± 5 °F (4.44 °C ± 2.77 °C).
- **HARSH Hostile-Area Smoke Head:**
- Provides early warning of smoke detection in environment where traditional smoke detectors are not practical.
  - The detector's filters remove particulates down to 30 microns in size.
  - Intake fan draws air into photo chamber, while airborne particles and water mist are removed.
  - Requires auxiliary 24 VDC from system or remote power supply.

## FEATURES (Continued)

- **Releasing features:**
  - Ten independent hazards
  - Sophisticated cross-zone (three options)
  - Delay timer and Discharge timers (adjustable)
  - Abort (four options)
  - Low Pressure CO<sub>2</sub> Listed
- **High-efficiency offline switching 3.0 amp power supply (6.0 A in alarm):**
  - 120 or 220/240 VAC
  - Displays battery current/voltage on panel (with display)

## FLASHSCAN EXCLUSIVE NEW WORLD-LEADING DETECTOR PROTOCOL

At the heart of the AUTOPULSE IQ-318 is a set of detection devices and device protocol — FlashScan (U.S. Patent 5,539,389). Flash-Scan is an all-digital protocol that gives superior precision and high noise immunity.

In addition to providing quick identification of an active input device, this new protocol can also activate many output devices in a fraction of the time required by competitive protocols.

This high speed also allows the AUTOPULSE IQ-318 to have the largest device per loop capacity in the industry – 318 points – yet every input and output device is sampled in less than two seconds. The microprocessor-based FlashScan detectors have bicolor LEDs that can be coded to provide diagnostic information, such as device address during Walk Test.

## INTELLIGENT SENSING

Intelligent sensing is a set of software algorithms that provides the AUTOPULSE IQ-318 with industry-leading smoke detection capability. These complex algorithms require many calculations on each reading of each detector, and are made possible by the very high-speed microcomputer used by the AUTOPULSE IQ-318.

**Drift Compensation and Smoothing:** Drift compensation allows the detector to retain its original ability to detect actual smoke, and resist false alarms, even as dirt accumulates. It reduces maintenance requirements by allowing the system to automatically perform the periodic sensitivity measurements required by NFPA 72. Smoothing filters are also provided by software to remove transient noise signals, such as those caused by electrical interference.

**Maintenance Warnings:** When the drift compensation performed for a detector reaches a certain level, the performance of the detector may be compromised, and special warnings are given. There are three warning levels: (1) Low Chamber value, usually indicative of a hardware problem in the detector; (2) Maintenance Alert, indicative of dust accumulation that is near but below the allowed limit; (3) Maintenance Urgent, indicative of dust accumulation above the allowed limit.

**Sensitivity Adjust:** Nine sensitivity levels are provided for alarm detection. These levels can be set manually, or can change automatically between day and night. Nine levels of pre-alarm sensitivity can also be selected, based on predetermined levels of alarm. Pre-alarm operation can be latching or self-restoring, and can be used to activate special control functions.

**Self-Optimizing Pre-Alarm:** Each detector may be set for “Self-Optimizing” pre-alarm. In this special mode, the detector “learns” its normal environment, measuring the peak analog readings over a long period of time, and setting the pre-alarm level just above these normal peaks.

**Cooperating Multi-Detector Sensing:** A patented feature of intelligent sensing is the ability of a smoke sensor to consider readings from nearby sensors in making alarm or pre-alarm decisions. Without statistical sacrifice in the ability to resist false alarms, it allows a sensor to increase its sensitivity to actual smoke by a factor of almost two to one.

## FIELD PROGRAMMING OPTIONS

Autoprogram is a timesaving feature of the AUTOPULSE IQ-318. It is a special software routine that allows the AUTOPULSE IQ-318 to “learn” what devices are physically connected and automatically load them in the program with default values for all parameters. Requiring less than one minute to run, this routine allows the user to have almost immediate fire protection in a new installation, even if only a portion of the detectors are installed.

**Keypad Program Edit (with KDM-R2):** The AUTOPULSE IQ-318, like all intelligent panels, has the exclusive feature of program creation and editing capability from the front panel keypad, **while continuing to provide fire protection.** The architecture of the AUTOPULSE IQ-318 software is such that each point entry carries its own program, including control-by-event links to other points. This allows the program to be entered with independent per-point segments, while the AUTOPULSE IQ-318 simultaneously monitors other (already installed) points for alarm conditions.

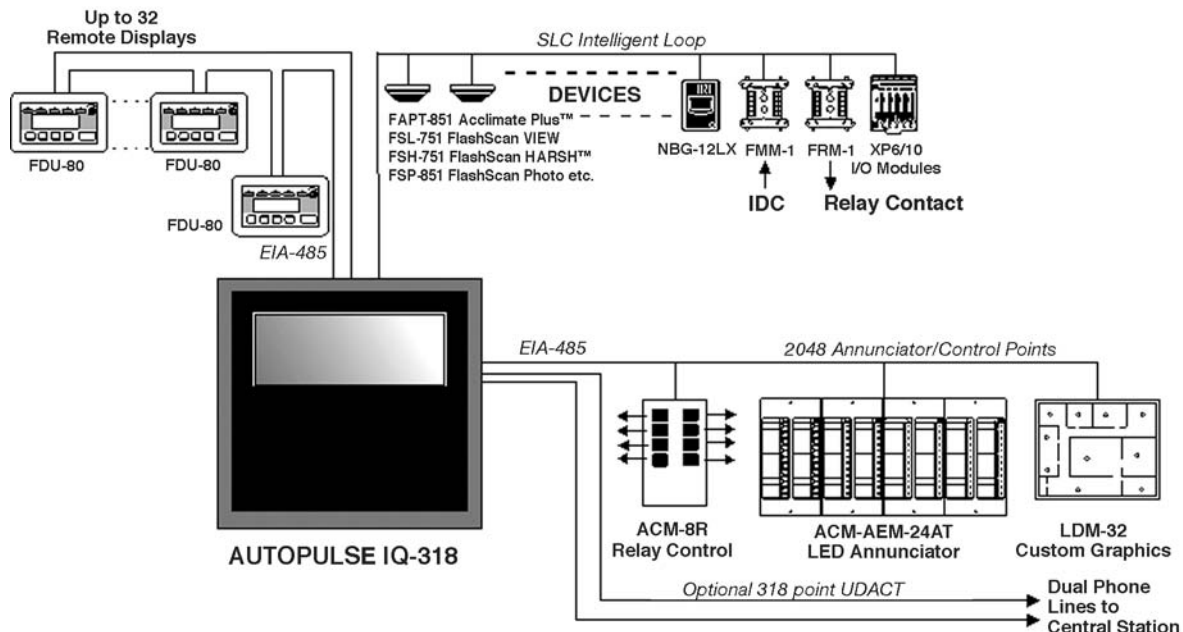

**VeriFire Tools** is an offline programming and test utility that can greatly reduce installation programming time, and increase confidence in the site-specific software. It is Windows®-based and provides technologically advanced capabilities to aid the installer. The installer may create the entire program for the AUTOPULSE IQ-318 in the comfort of the office, test it, store a backup file, then bring it to the site and download from a laptop into the panel.

AUTOPROGRAM PLEASE WAIT

L1:80 DETS, 15 MODS  
BELLS: 04

**Autoprogram Function**

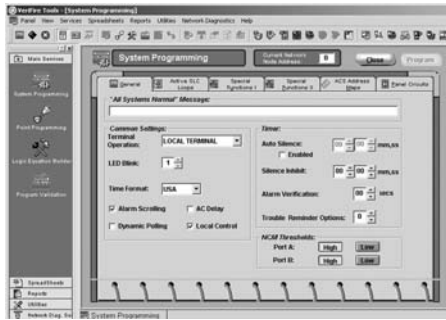

**VeriFire™ Tools System Programming Screen**

007187

**PLACEMENT OF EQUIPMENT IN CHASSIS AND CABINET**

The following guidelines outline the AUTOPULSE IQ-318's flexible system design.

**Wiring:** When designing the cabinet layout, consider separation of power-limited and non-power-limited wiring as discussed in the AUTOPULSE IQ-318 Installation Manual.

It is critical that all mounting holes of the AUTOPULSE IQ-318 are secured with a screw or standoff to ensure continuity of Earth Ground.

**Equipment Placement in AUTOPULSE IQ-318 Chassis**

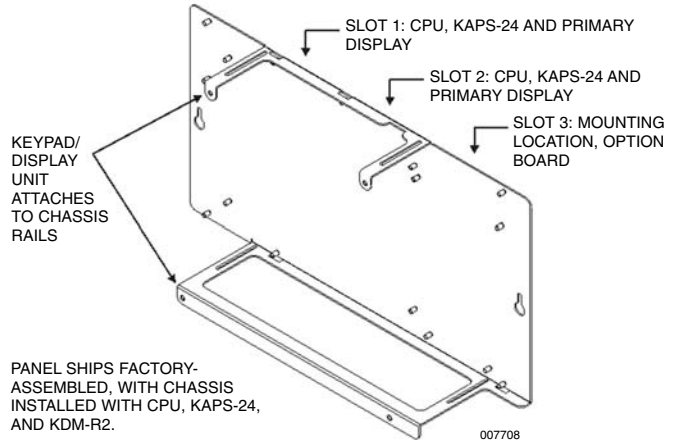

PANEL SHIPS FACTORY-ASSEMBLED, WITH CHASSIS INSTALLED WITH CPU, KAPS-24, AND KDM-R2.

007708

**CPU-318 Board Diagram**

- TB10:** DC Power (24 VDC, power-limited); Non-Resettable, Resettable.
- TB11:** EIA-485 Connection (supervised); Terminal Mode, ACS Mode.
- TB12:** EIA-232 Connection; Printer, PC/Terminal (CRT).

- J1:** Network/Service Connection (NUP), power-limited, supervised.
- J2:** USB A VeriFire Tools Connection.
- J3:** USB B VeriFire Tools Connection.

All NAC circuits are power-limited, supervised.

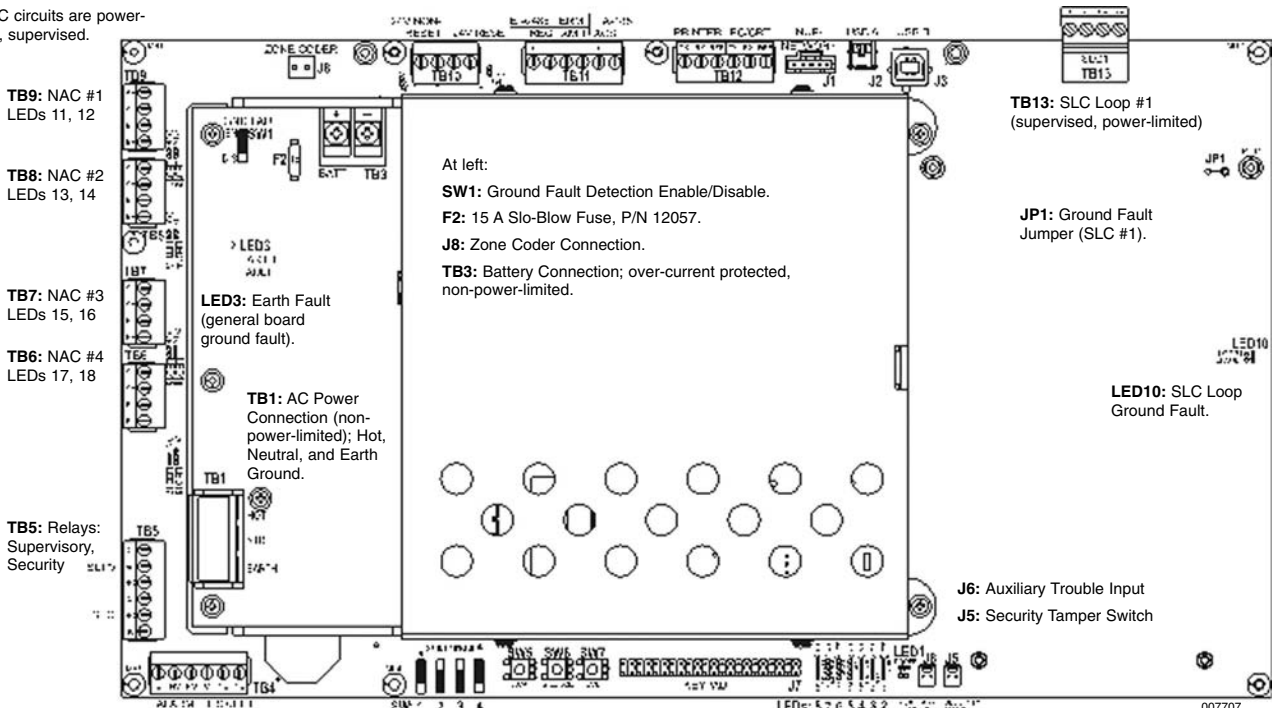

- TB4:** Alarm Relay, Trouble Relay. Output relays; power-limited only if connected to a power-limited source.

- SW1, SW2, SW3, SW4:** Disable-Enable switches for Backup Alarm, NACs 1-4 respectively.

- System switches, "No Keyboard Operation":  
**SW5** Acknowledge  
**SW6** Silence

- SW7** Reset  
**J7** KDM-R2 Connection

- LED1:** Power On (AC or battery)
- LED2:** Signals Silenced
- LED3:** Point Disabled
- LED4:** System Trouble
- LED5:** Supervisory

- LED6:** Security
- LED7:** Pre-Alarm
- LED8:** Fire Alarm

007707

## KDM-R2 CONTROLS AND INDICATORS

**Program Keypad:** QWERTY type (keyboard layout).

**12 LED Indicators:** Power; Fire Alarm; Pre-Alarm; Security; Supervisory; System Trouble; Signals Silenced; Points Disabled; Control Active; Abort; Pre-Discharge; Discharge.

**Membrane Switch Controls:** Acknowledge/Scroll Display; Signal Silence; Drill; System Reset; Lamp Test.

**LCD Display:** 80 characters (2 x 40) with long-life LED backlight.

## CONFIGURATION GUIDELINES

The AUTOPULSE IQ-318 system ships assembled; description and some options follow.

**AUTOPULSE IQ-318:** The standard, factory-assembled AUTOPULSE IQ-318 panel includes the following components: one CPU-318 control panel mounted on chassis (120 V operation – ships with grounding cable, battery interconnect cables, and document kit); one KAPS-24 integral power supply mounted to the CPU-318; one primary display KDM-R2 keypad/display; and one cabinet for surface or semi-flush mounting. Purchase batteries separately. One or two option boards may be mounted inside the AUTOPULSE IQ-318 cabinet; additional option boards can be utilized in remote cabinets.

**AUTOPULSE IQ-318C:** Same as AUTOPULSE IQ-318 above, but with ULC listing.

**AUTOPULSE IQ-318E:** Same as AUTOPULSE IQ-318 above, but with 240 V operation.

**BMP-1:** Blank module for unused module positions.

**TR-318:** Trim ring for the AUTOPULSE IQ-318 cabinet.

## OPTION MODULES

**FCPS-24S6/24S8:** Remote six-amp and eight-amp power supplies with battery charger.

### COMPATIBLE DEVICES, EIA-485 PORTS

**ACM-24AT:** ACS annunciator – up to 96 points of annunciation with Alarm or Active LED, Trouble LED, and switch per circuit. Active/Alarm LEDs can be programmed (by powered-up switch selection) by point to be red, green, or yellow; the Trouble LED is always yellow.

**AEM-24AT:** Same LED and switch capabilities as ACM-24AT, expands the ACM-24AT to 48, 72, or 96 points.

**ACM-48A:** ACS annunciator – up to 96 points of annunciation with Alarm or Active LED per circuit. Active/Alarm LEDs can be programmed (by powered-up switch selection) in groups of 24 to be red, green, or yellow. Expandable to 96 points with one AEM-48A.

**AEM-48A:** Same LED capabilities as ACM-48A, expands the ACM-48A to 96 points.

**TM-4:** Transmitter Module. Includes three reverse-polarity circuits and one municipal box circuit; mount on AUTOPULSE IQ-318 chassis or remotely.

**FDU-80:** Remote LCD display, 80 characters, with LEDs.

**LDM:** Lamp Driver Modules LDM-32, LDM-E32, and LDMR32; remote custom driver modules.

**ACM-8R:** Remote Relay Module with eight Form-C contacts. Can be located up to 6,000 ft (1828.8 m) from panel on four wires.

**UDACT:** Universal Digital Alarm Communicator Transmitter, 636 channel.

## COMPATIBLE INTELLIGENT DEVICES

**FSI-851:** Low-profile FlashScan ionization detector, will replace FSI-751.

**FSI-751:** Low-profile FlashScan ionization detector.

**FSP-851:** Low-profile FlashScan photoelectric detector, will replace FSP-751.

**FSP-751:** Low-profile FlashScan photoelectric detector.

**FSP-851T:** Low-profile FlashScan photoelectric detector with 135 °F (57 °C) thermal, will replace FSP-751T.

**FSP-751T:** Low-profile FlashScan photoelectric detector with 135 °F (57 °C) thermal.

**FST-851:** FlashScan thermal detector 135 °F (57 °C), will replace FST-751.

**FST-751:** FlashScan thermal detector 135 °F (57 °C).

**FST-851R:** FlashScan thermal detector 135 °F (57 °C) with rate-of-rise, will replace FST-751R.

**FST-751R:** FlashScan thermal detector 135 °F (57 °C) with rate-of-rise.

**FST-851H:** FlashScan 190 °F (88 °C) high-temperature thermal detector.

**FSD-751P:** FlashScan photo duct detector with housing.

**FSD-751PL:** Low-flow FlashScan photo duct detector with housing, will replace FSD-751P.

**FSD-751RP:** FlashScan photo duct detector with relay and housing.

**FSD-751RPL:** Low-flow FlashScan photo duct detector with relay and housing, will replace FSD-751RP.

**FAPT-851:** FlashScan Acclimate Plus low-profile multi-sensor detector, will replace FAPT-751.

**FAPT-751:** Acclimate Plus low-profile multisensor detector.

**FSH-751:** FlashScan HARSH Hostile Area Smoke Head.

**FSL-751:** FlashScan VIEW laser photo detector.

**LPX-751:** Low-profile VIEW laser photo detector.

**B224RB:** Low-profile relay base.

## OPTION MODULES (Continued)

- B224BI:** Isolator base for low-profile detectors.
- B710LP:** Low-profile base. Standard U.S. style.
- B501:** European-style, 4 in. (10.16 cm) base.
- B501BH:** Sounder base, includes B501 base above.
- FMM-1:** FlashScan monitor module.
- FDM-1:** FlashScan dual monitor module.
- FZM-1:** FlashScan two-wire detector monitor module.
- FMM-101:** FlashScan miniature monitor module.
- FCM-1:** FlashScan NAC control module.
- FRM-1:** FlashScan relay module.
- NBG-12LX:** Manual fire alarm station, addressable.
- ISO-X:** Isolator module.
- XP6-C:** FlashScan six-circuit supervised control module.
- XP6-MA:** FlashScan six-zone interface module; connects intelligent alarm system to two-wire conventional detection zone.
- XP6-R:** FlashScan six-relay (Form-C) control module.
- XP10-M:** FlashScan ten-input monitor module.

## OTHER OPTIONS

- VeriFire-TCD:** VeriFire Tools CD-ROM. Contains programming software. Includes local panel connection cable. Programming PC requires a serial port connection.
- BAT Series:** Batteries. AUTOPULSE IQ-318 utilizes two 12 volt, 18 to 200 AH batteries. This series of products replaces the previous PS Series.
- NFS-LBB:** Battery Box (required for batteries over 25 AH).
- NFS-LBBR:** Same as above, but red.

## SYSTEM SPECIFICATIONS

### System Capacity

Intelligent Signaling Line Circuits . . . . .	1
Intelligent detectors . . . . .	159
Addressable monitor/control modules . . . . .	159
Programmable internal hardware and output circuits . . . . .	4
Programmable software zones. . . . .	99
Special programming zones . . . . .	14
LCD annunciators per CPU-318/318E . . . . .	32
ACS annunciators per CPU-318/318E . . . . .	32 addresses x 64 points

### Specifications

- Primary input power, **CPU-318 board:** 120 VAC, 50/60 Hz, 3.0 A. **CPU-318E board:** 220/240 VAC, 50/60 Hz, 1.5 A.
  - Total output 24 V power: 6.0 A in alarm.
- Note:** The power supply has a total of 6.0 A of available power. This is shared by all internal circuits.
- Standard notification circuits (4): 1.5 A each.
  - Four-wire detector power: 1.25 A.
  - Non-resettable regulated power outputs: 1.25 A each.
  - Battery charger range: 18 AH – 200 AH. Use separate cabinet for batteries over 25 AH.
  - Optional high-capacity (25 – 120 AH) battery charger: CHG-120.
  - Float rate: 27.6 V.

### Cabinet Specifications

- AUTOPULSE IQ-318 cabinet dimensions:
- BACKBOX, OUTSIDE: 18.240 in. (46.33 cm) height, 5.77 in. (14.656 cm) deep.
- WITH DOOR: 18.870 in. (47.93 cm) wide x 18.469 in. (46.911 cm) high x 5.817 in. (14.775 cm) deep.
- BACKBOX, INSIDE: 18.120 in. (46.025 cm) inner width, 5.175 in. (13.145 cm) inner depth.

### Temperature and Humidity Ranges

This system meets NFPA requirements for operation at 32 – 120 °F (0 – 49 °C) and at a relative humidity 93% ± 2% RH (noncondensing) at 90 °F ± 3 °F (32 °C ± 2 °C). However, the useful life of the system's standby batteries and the electronic components may be adversely affected by extreme temperature ranges and humidity. Therefore, it is recommended that this system and its peripherals be installed in an environment with a normal room temperature of 60 – 80 °F (15 – 27 °C).



**STANDARDS**

The AUTOPULSE IQ-318 complies with the following UL Standards and NFPA 72 Fire Alarm Systems requirements:

- UL 864, 9th Edition.
- UL 1076 (Burglary).
- LOCAL (Automatic, Manual, Waterflow and Sprinkler Supervisory).
- AUXILIARY (Automatic, Manual and Waterflow) (requires 4XTMF).
- REMOTE STATION (Automatic, Manual and Waterflow) (requires 4XTMF).
- PROPRIETARY (Automatic, Manual and Waterflow). Not applicable for FM.

**AGENCY LISTINGS AND APPROVALS**

These listings and approvals apply to the basic AUTOPULSE IQ-318 control panel. In some cases, certain modules may not be listed by certain approval agencies, or listing may be in process. Consult factory for latest listing status.

The AUTOPULSE IQ-318 complies with UL Standards 864, 9th Edition (Fire). It is designed to meet NFPA 72 Local, Auxiliary, Remote Station, and Proprietary (not applicable for FM) Fire System Requirements.

UL Listed . . . . .	S4935
ULC . . . . .	S4935
MEA . . . . .	128-07-E
FM . . . . .	Pending
California State Fire Marshall . . . . .	Pending

**ORDERING INFORMATION**

<u>Part No.</u>	<u>Description</u>
434957	AUTOPULSE IQ-318 FACP, 120 VAC
434958	AUTOPULSE IQ-318C FACP, 120 VAC (ULC)
434959	AUTOPULSE IQ-318E FACP, 240 VAC

ANSUL and AUTOPULSE are trademarks of Ansul Incorporated or its affiliates.

Acclimate Plus™ and HARSH™ are trademarks; and FlashScans®, NION®, NOTIFIER®, UniNet®, VeriFire®, and VIEW® are registered trademarks of Honeywell International Inc. Microsoft® and Windows® are registered trademarks of Microsoft Corporation. Echelon® is a registered trademark of Echelon Corporation. IBM® is a registered trademark of IBM Corporation. ©2007 by Honeywell International Inc. All rights reserved. Unauthorized use of this document is strictly prohibited.