

CO₂ Component Description

Pressure Operated Siren

Effective: April 2002

K-81-5220

P/N: 981574

NOMINAL FLOW RATE AT 70 DEGREES	
CARBON DIOXIDE	20.4 LBS/MIN
HALON 1301	21.2 LBS/MIN

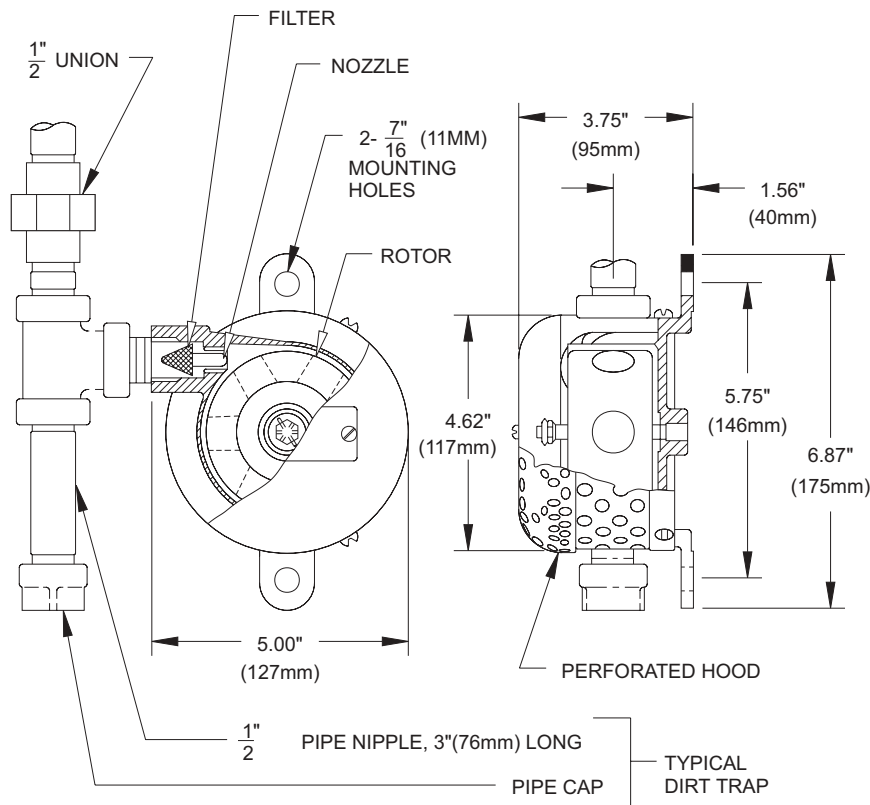

MATERIALS

BODY: BRONZE

ROTOR: BRASS

NOZZLE AND FILTER: MONEL

HOOD: STEEL

FINISH: RED PAINT

This literature is provided for informational purposes only. KIDDE-FENWAL, INC. assumes no responsibility for the product's suitability for a particular application. The product must be properly applied to work correctly. If you need more information on this product, or if you have a particular problem or question, contact KIDDE-FENWAL INC., Ashland, MA 01721. Telephone: (508) 881-2000

Kidde Fire Systems
400 Main Street
Ashland, MA 01721 USA
Tel: (508) 881-2000
Fax: (508) 881-8920
<http://www.kiddefiresystems.com>