

SELECTOR VALVES

APPLICATION

Selector Valves allow a single agent supply to be utilized for protection of multiple hazards, reducing the total amount of agent required.

Selector Valves are used to direct the flow of agent (Clean Agent or Carbon Dioxide) into one specific hazard of a multiple hazard application.

DESCRIPTION

The Selector Valve body is available in either carbon steel or stainless steel. The valve is a ball valve that blocks the flow of agent through the piping network until the valve is activated. Valve actuation is accomplished either manually or electrically.

Manual actuation is accomplished by removing a ring pin and pushing a manual actuation button down. Electric actuation is accomplished when an electrical signal is received by the 24Vdc electric solenoid. Both of these actuation methods result in the opening of a nitrogen cartridge that pneumatically opens the Selector Valve. Each Selector Valve is equipped with valve position monitor that gives a visual indication if the valve is open or closed.

A typical Selector Valve assembly is made-up of the following items:

- Selector Valve with Actuator and relief/pop-off valve
- Solenoid Actuator Kit or Slave Actuator Kit
- 1/4" check valve and 1/4"-90 Degree Elbow
- 1/4" SST Flexible Hose x 3' Long

Selector Valves are available in 1, 1 1/2, 2 and 3" with NPT threads. Reducing bushings are utilized when connecting to a 1/2, 3/4, 1/4 or 2 1/2" pipe. For details on the Actuator Kits refer to Fike Data Sheets C.1.48.01 and C.1.49.01.

INSTALLATION

The Selector Valve is installed in the supply piping for the hazard being protected. These valves can be mounted in either the horizontal or vertical position. All the necessary parts are provided to install the Actuator within 3 feet (0.9 m) of the Selector Valve. The Actuator can be located up to 42 feet (13.0 m) from the Selector Valve.

APPROVALS

- F.M.



Form No. C.1.38.01-7

DIMENSIONAL INFORMATION

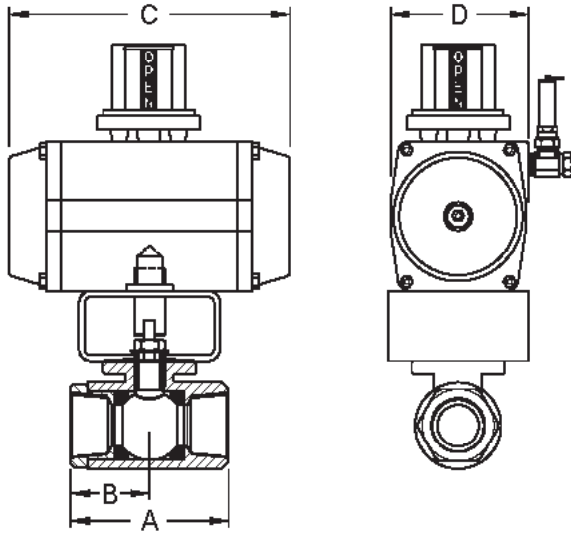

Part Number	Size Inches (mm)	Type	A	B	C	D
			Inches (mm)			
70-1899-10	1 (25)	Threaded	3.37 (86)	1.68 (43)	7.95 (202)	3.34 (85)
70-1899-15	1 1/2 (40)	Threaded	4.37 (111)	2.18 (55)	9.05 (230)	3.85 (98)
70-1899-20	2 (50)	Threaded	5.50 (140)	2.75 (70)	10.66 (271)	4.33 (110)
70-1899-30	3 (80)	Threaded	6.75 (171)	3.37 (86)	14.17 (360)	5.51 (140)



Copyright © Fike Corporation All Rights Reserved.
Form No. C.1.38.01-7 October, 2008 Specifications are subject to change without notice.