



Selector Valves

Description

Selector valves are used to direct the flow of INERGEN® into a single hazard or a multiple hazard system.

When pneumatic actuation is required for the 1 in. and 2 in. valves, a Stackable Actuator Assembly, Part No. 428566, must be ordered separately.

When electric actuation is required for the 1 in. and 2 in. valves, a Booster Actuator, Part No. 428949, must be ordered separately.

When electric actuation is required for the 2 1/2 in., 3 in. and 4 in. valves, a Selector Valve Electric Actuation Kit, Part No. 426893, must be ordered separately. **NOTE:** These selector valves cannot be pressure operated.

Selector valves can be manually operated by mounting a lever actuator either directly onto the valve or onto the top of the electric actuator. See Lever Release Actuator Component Sheet for correct actuator.

Component	Material	Thread Size/Type	Approvals	Equivalent Length (Sch. 80 Pipe)
▶ 1 in. Selector Valve (Used for 1/2 in., 3/4 in. and 1 in. pipe sizes)	Bronze	1 in. NPT Female	UL (EX-4510), FM	1/2 in. – 1.9 ft. (0.6 m) 3/4 in. – 6.4 ft. (1.9 m) 1 in. – 10.4 ft. (3.2 m)
▶ 2 in. Selector Valve (Used for 1 1/4 in., 1 1/2 in. and 2 in. pipe sizes)	Bronze	2 in. NPT Female	UL (EX-4510), FM	1 1/4 in. – 16.2 ft. (4.9 m) 1 1/2 in. – 22.4 ft. (6.8 m) 2 in. – 67.4 ft. (20.5 m)
▶ 2 in., 2 1/2 in., 3 in. Selector Valve	Ductile Iron	3 in. Flange American Standard Raised Face	UL (EX-4510), FM	2 in. – 17 ft. (5.2 m) 2 1/2 in. – 43 ft. (13.1 m) 3 in. – 78 ft. (23.8 m)
▶ 4 in. Selector Valve	Ductile Iron	4 in. Flange American Standard Raised Face	UL (EX-4510), FM	4 in. – 111 ft. (33.8 m)

NOTE: The 3 in. and 4 in. flanged selector valves latch open upon actuation. They must be manually reset by pulling out the reset knob on the side of the pressure actuator. If the valve is not reset, it will reopen the next time the system is actuated, even if a different hazard requires protection.

Shipping Assembly Part No.	Description
427185	1 in. selector valve – threaded
427150	2 in. selector valve – threaded
857433	2, 2 1/2, 3 in. selector valve – flanged
857445	4 in. selector valve – flanged
426893	Electric actuator kit
842402	Brass cap
428566	Pressure operated stackable actuator

NOTE: A lever actuator, brass cap, or CV-98 electric actuator, must be used with each selector valve. Valve will not operate properly without one of these on top of pressure actuator assembly.

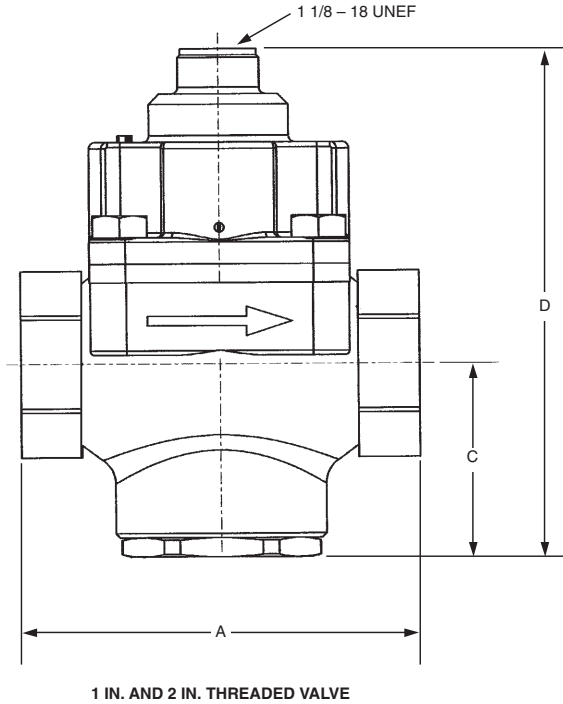
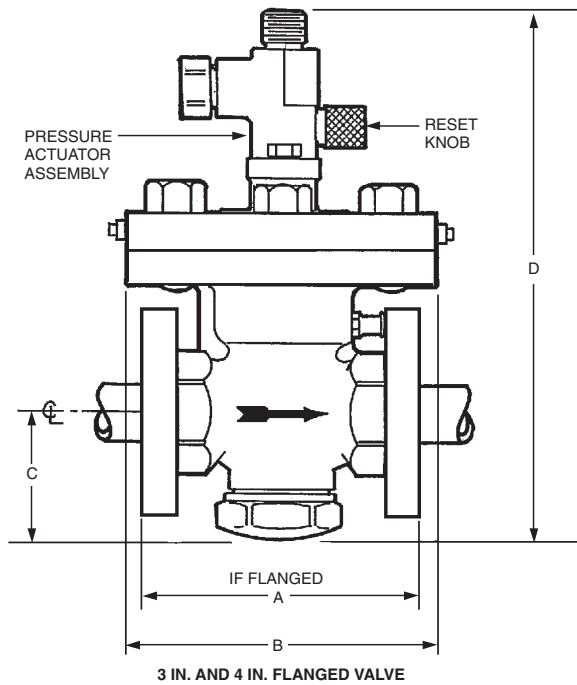

006035

Valve Size	Body	A		B		C		D	
		in.	(mm)	in.	(mm)	in.	(mm)	in.	(mm)
1 in.	Threaded – 1 in. NPT female	5 1/2	(140)	—		2 9/16	(67)	7	(178)
2 in.	Threaded – 2 in. NPT female	7 1/2	(191)	—		3 1/2	(89)	8 9/16	(218)
2 in., 2 1/2 in., 3 in.	Flanged – 3 in.	13	(330)	5 3/4	(146)	6 1/8	(156)	16 1/4	(413)
4 in.	Flanged – 4 in.	16	(406)	5 3/4	(146)	8 3/4	(222)	19 7/8	(505)