



Valve Electric Actuation

Description

Electrical actuation of an agent cylinder and/or selector valves is accomplished by an HF electric actuator interfaced through an AUTOPULSE® Control System. This actuator can be used in hazardous environments where the ambient temperature range is between 0 °F to 130 °F (–18 °C to 54 °C). The HF electric actuator meets the requirements of N.E.C. Class I, Div. 1, Groups B, C, D and Class II, Div. 1, Groups E, F, G. A maximum of two HF electric actuators can be used on a single AUTOPULSE release circuit. When utilizing only one HF electric actuator, an in-line resistor, Part No. 73606, is required in the supervised release circuit.

The actuator specifications are:

Nominal Voltage	Rated Voltage	
	Minimum	Maximum
12 VDC @ 0.57 amps	10.4 VDC*	14.0 VDC

In auxiliary or override applications, a manual-local override valve actuator or a manual cable pull actuator can be installed on top of the HF electric actuator by removing the safety cap.

A reset tool is required to reset the actuator after operation. The actuator contains a standard 1/2 in. threaded female straight connector for electrical conduit hookup.

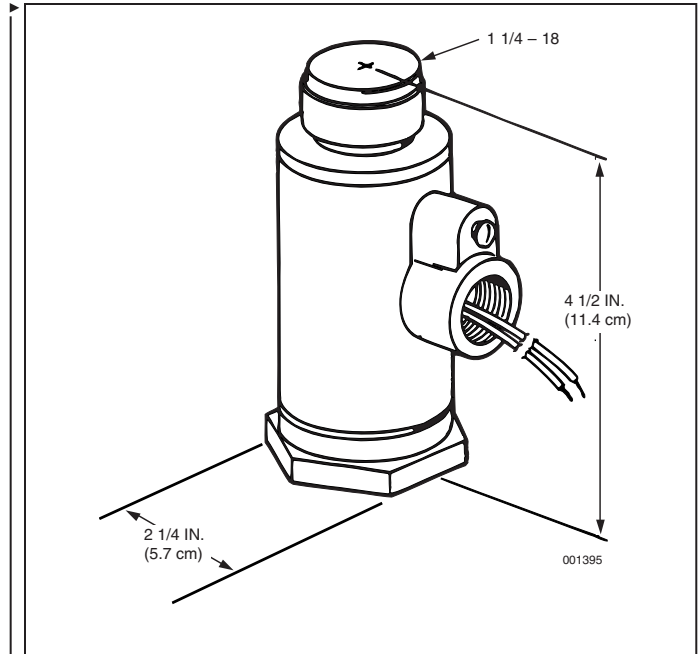

Shipping Assembly Part No.	Description
73327	HF electric actuator
75433	HF Reset Tool

Component	Material	Thread Size/Type	Approvals
HF Electric Actuator	Body: Brass Plunger: Stainless Steel	1/2 in. Straight Female	UL (EX-4510) FM Approved

*Minimum operating voltage is 9.0 VDC.

Description

The Booster Actuator, Part No. 428949, is used when electric actuation is required on the selector valve or the CV-98 cylinder valve. The actuator mounts directly to the component and then a HF electric actuator mounts to the top of the booster actuator.

The Booster Actuator requires resetting after actuation. A Reset Tool, Part No. 429847, is available for this use.

