

FEATURES

- **Compatible with PEGAsys™ Addressable Contact Input Devices (AI)**
- **Permits LHS installation in Classified Hazardous Areas**
- **1-Channel Operation**
- **Shunt-Diode Type**
- **Limits Energy**
- **Slim Packaging**
- **UL Listed**
- **FM Approved**

DESCRIPTION

Linear Heat Sensor (LHS™) applications, in classified hazardous areas with potentially explosive vapors, dust or fibers, require the use of Intrinsic Safety Barriers so as to limit the total energy entering the hazard via the sensor wiring conductors.

Kidde P/N 73-117068-201 shunt-diode Safety Barriers are 1-channel devices that use intrinsically safe techniques to allow electrical signals to be conveyed between non-hazardous (safe) and hazardous areas. The Safety Barriers achieve this by limiting the transfer of energy in one direction to a level that cannot cause ignition of explosive atmospheres.

WIRING

As shown in Figure 1, the Intrinsic Safety Barrier (P/N 73-117068-201) is used in Intelligent LHS applications where SmartOne® Addressable Contact Input Devices (AI) interface one circuit of the LHS cable to the PEGAsys™ Control Panel. Each Intrinsic Safety Barrier handles two conductors and hence only one Safety Barrier is required for each LHS circuit.

INSTALLATION

Intrinsic Safety Barriers—with dimensions as shown in Figure 2 and Figure 3—must be enclosed in a separate weather-tight enclosure. Kidde offers multi-barrier enclosures suitable for 2, 5, 12, 24 and 32 barriers (see Ordering Information for part numbers).

To determine if the need for an intrinsically safe circuit exists on a specific application, consult the National Electric Code and the local Authority Having Jurisdiction (AHJ).

REFERENCE DOCUMENTATION

- Kidde® Linear Heat Detection Color Brochure: KF-0070
- Kidde LHS™ Data Sheet: 73-06
- Kidde LHS™ Installation Instructions: 73-202
- Kidde Application Guide—Intelligent LHS™ Systems: 73-100
- Kidde PEGAsys™ Color Brochure: KF-0045
- Kidde PEGAsys™ Data Sheet: 76-000
- SmartOne® Addressable Input Module Data Sheet: 74-214

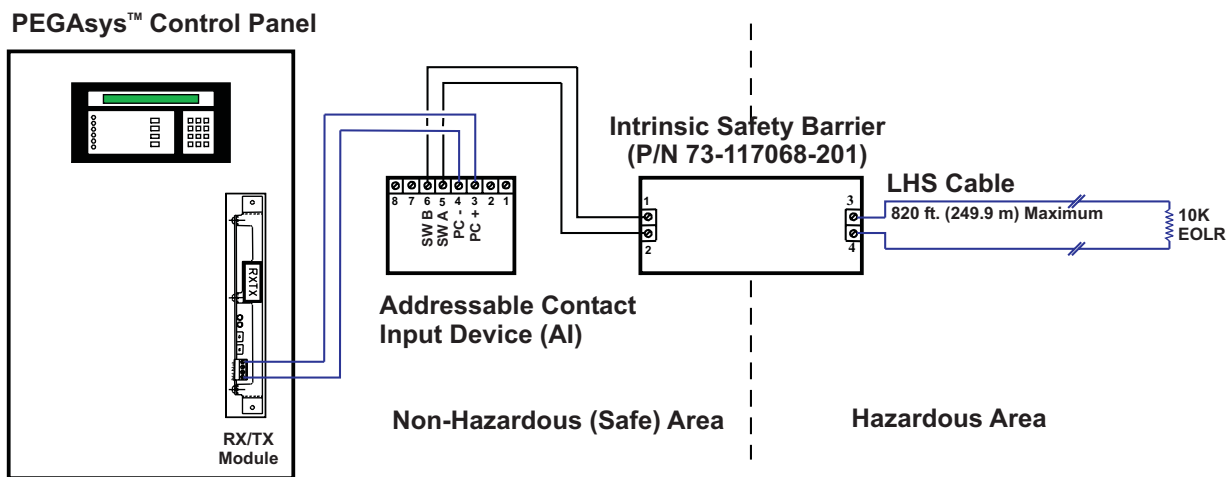

Figure 1. Typical Schematic Wiring Diagram

DIMENSIONS

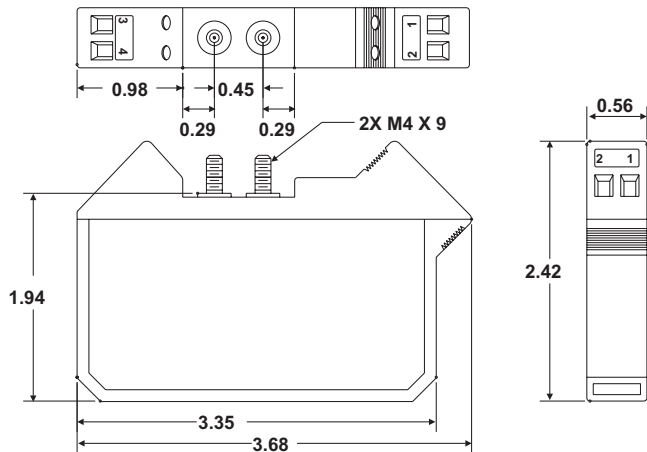

Figure 2. Intrinsic Safety Barrier Dimensions (Inches)

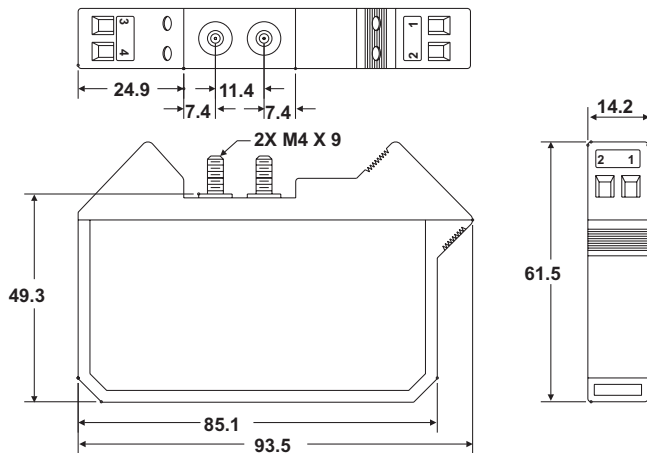

Figure 3. Intrinsic Safety Barrier Dimensions (Metric)

SPECIFICATIONS

FM Approvals	Class I, Division 1, Groups A, B, C, D Class II, Division 1, Groups E, F, G Class III, Division 1
Operating Temperature Range	-4°F to 140°F (-20°C to 60°C)
Humidity	5 to 95% RH
Terminals	Accept up to #12 AWG; Hazardous Area terminals identified by blue labels
Working Voltage	10 V
Maximum Voltage	11.2 V
Fuse Rating	50 mA
End-to-End Resistance	185 ohms maximum
Weight	Approximately 0.275 lb. (0.125 kg)
Mounting and Earthing	By two integral tin-plated steel fixing studs and stainless steel self-locking nuts (provided)

ORDERING INFORMATION

Part Number	Description
73-117068-201	Intrinsic Safety Barrier for Intelligent LHS (need one per circuit)
73-117068-032	Intrinsic Safety Barrier Weathertight Enclosure. Holds 2 Barriers.
73-117068-033	Intrinsic Safety Barrier Weathertight Enclosure. Holds up to 5 Barriers.
73-117068-034	Intrinsic Safety Barrier Weathertight Enclosure. Holds up to 12 Barriers.
73-117068-035	Intrinsic Safety Barrier Weathertight Enclosure. Holds up to 24 Barriers.
73-117068-036	Intrinsic Safety Barrier Weathertight Enclosure. Holds up to 32 Barriers.

Kidde® and SmartOne® are registered trademarks of Kidde-Fenwal, Inc.
LHS™ and PEGAsys™ are trademarks of Kidde-Fenwal, Inc.

This literature is provided for informational purposes only. KIDDE-FENWAL, INC. assumes no responsibility for the product's suitability for a particular application. The product must be properly applied to work correctly. If you need more information on this product, or if you have a particular problem or question, contact KIDDE-FENWAL, INC., Ashland, MA 01721. Telephone: (508) 881-2000.



A UTC Fire & Security Company

400 Main Street
Ashland, MA 01721
Ph: 508.881.2000
Fax: 508.881.8920

www.kiddefiresystems.com