

# Microswitch Kits for KRS-50 Control Box

P/Ns: 60-9197227-000 and 60-9197228-000

## FEATURES

- For Use in WHDR™ Commercial Cooking Fire Suppression Systems

## DESCRIPTION

The Single SPDT Microswitch Kit includes a single pole, double-throw microswitch (Figure 1). The Dual SPDT Microswitch Kit includes two single pole, double throw (SPDT) microswitches (Figure 2). Included in the kit:

- Microswitch
- Pigtail assembly
- Mounting bracket and hardware (screws, lockwashers and hex nuts)
- Microswitch mounting hardware (screws, lockwashers and hex nuts)

The wire leads are 24-inches (610 mm) in length. One Single SPDT or one Dual SPDT Microswitch Kit can be mounted in the KRS Control Box.

These are used when it is necessary to open or close electrical circuits. Examples include, but are not limited to:

- Electric appliance shutdown
- Make up air shutdown
- Electric gas valve shutdown
- Shuntbreaker/relay

Electrical appliances usually have a higher amp rating than the microswitch. In this case, such appliances shall not be wired directly to the microswitch. A magnetic contactor or relay must be used.

For wiring the microswitches for the KRS-50, refer to Figure 3.

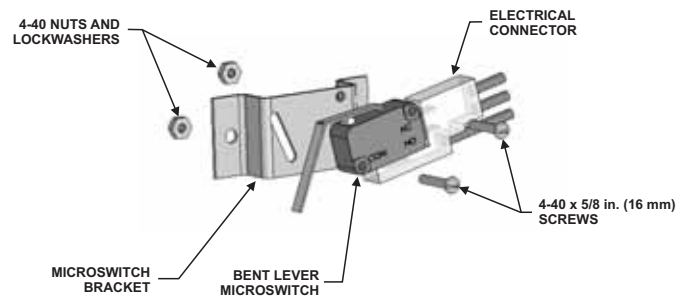

Figure 1. Single SPDT Microswitch Kit  
P/N 60-9197227-000

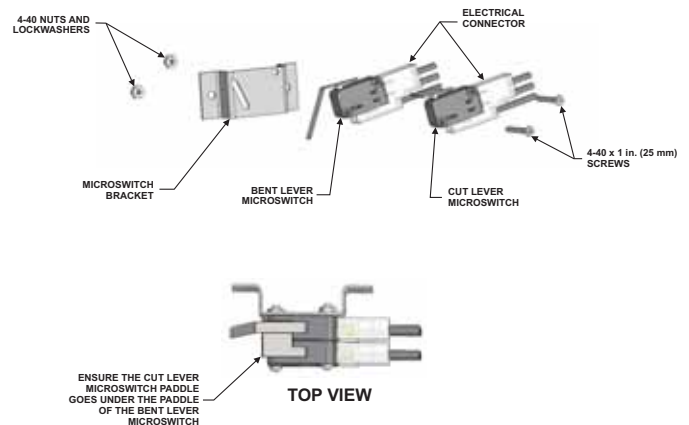

Figure 2. Dual SPDT Microswitch Kit,  
P/N 60-9197228-000

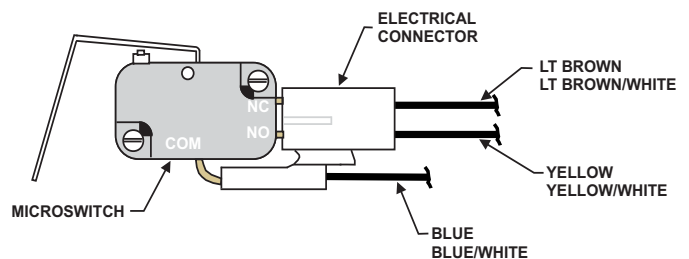

Figure 3. Microswitch Connection

Table 1. Electrical Ratings

125/250/277 Vac	15 Amps
125/250/277 Vac	1/2 HP
125 Vdc	1/2 Amp
250 Vdc	1/4 Amp
120 Vac "L"	5.0 Amp

Kidde is a registered trademark of Kidde-Fenwal, Inc.  
WHDR is a trademark of Kidde-Fenwal, Inc.

This literature is provided for informational purposes only. KIDDE-FENWAL, INC. assumes no responsibility for the product's suitability for a particular application. The product must be properly applied to work correctly.  
If you need more information on this product, or if you have a particular question, contact KIDDE-FENWAL, INC., Ashland, MA 01721. Telephone: (508) 881-2000.