

FM-200[®] Component Description



A UTC Fire & Security Company

2-Inch Swing Check Valve

Effective: April 2007
K-90-9042

FEATURES

- *Low Equivalent Length*
- *For Use with Multiple Cylinder Manifolds and Main/Reserve Systems*
- *UL Listed*

DESCRIPTION

The 2-inch Swing Check Valve is installed at each container (10 through 350 lb. container size) in a multiple cylinder container system to permit removal of containers while maintaining a closed system. The check valve may also be installed in main and reserve system configurations. Inlet and outlet connections are 2-inch female NPT. The check valve can be mounted in an upright horizontal orientation or a vertical orientation with the outlet at the top.

OPERATION

In the case of multiple cylinder installations, the check valve prevents back flow from the manifold in the event that the system is discharged when one or more cylinders are disconnected, such as when weighing or during general servicing. In the case of the check valve being used in a main and reserve configuration, it prevents the actuation of the reserve system from manifold pressure.

INSTALLATION

The check valve can be installed between zero and ninety degrees from the horizontal. The check valve must be installed so that the arrow is pointing in the required direction of flow.

ORDERING INFORMATION

The part number for ordering the 2-inch swing check valve is 06-118213-001.

SPECIFICATIONS

- Valve body and cover: Bronze
- Service pressure: 600 psi



DIMENSIONS

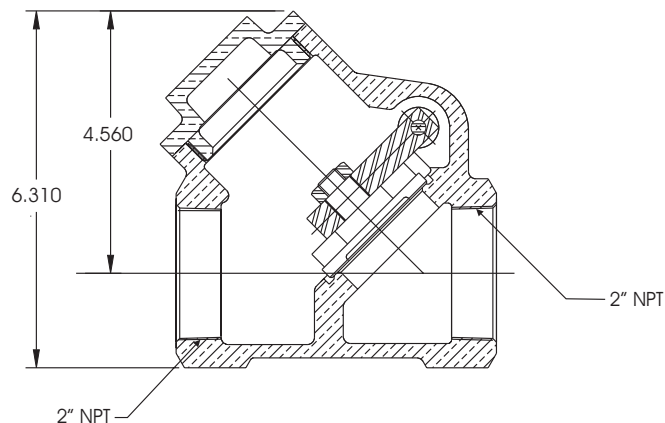

FM-200 is a registered trademark of the Great Lakes Chemical Corporation.

This literature is provided for informational purposes only. KIDDE-FENWAL, INC. assumes no responsibility for the product's suitability for a particular application. The product must be properly applied to work correctly. If you need more information on this product, or if you have a particular problem or question, contact KIDDE-FENWAL, INC., Ashland, MA 01721. Telephone: (508) 881-2000.