

CR Series

CR24™ 2' x 4' Architectural LED Troffer

Rev. Date: V6 01/09/2020

Product Description

The CR24™ architectural LED troffer delivers up to 130 lumens per watt of exceptional 90 CRI light at 4000 lumens. This breakthrough performance is achieved by combining the high efficacy and high-quality light of Cree TrueWhite® Technology with a unique thermal management design. Its design makes the CR24 perfect for use in commercial new construction or renovated spaces. The CR24 product family is available in warm, neutral, cool, or daylight color temperatures and has step, 0-10V, or Lutron EcoSystem® Enabled dimming options.

Performance Summary

Utilizes Cree TrueWhite® Technology (90 CRI)
Room-Side Heat Sink
Efficacy: 90-130 LPW
Initial Delivered Lumens: 2,200, 3,100, 4,000, 5,000 lumens
Input Power: 22-50 watts
CRI: 90 CRI (Cree TrueWhite® Technology), 80+ CRI (HD)
CCT: 3000K, 3500K, 4000K, 5000K
Input Voltage: 120-277 VAC or 347 VAC
Limited Warranty: 10 years
Limited Warranty Emergency Back Up (EB) Battery: 1 Year Battery Back Up. Test regularly in accordance with local codes
Controls: Step Level to 50%, 0-10V Dimming to 5% or Lutron EcoSystem Enabled to 5%
Mounting: Recessed*; surface or suspended w/surface mount kit accessory

* See <http://creelighting.com/warranty> for warranty terms

* Acceptable for use with standard 9/16 T-Bar or larger when installed per installation instructions. Consult factory for non-standard grid applications

Accessories

Field-Installed		
Adjustable Power Feeds with Cable Support Canopy Kits AC5-18/4-72-PD8-JB - Requires use of surface mount kit Adjustable Cable Support Kits AC5-72-PD8-JB - Requires use of surface mount kit Wireless 0-10V Dimming/Switching Interface with Cree SmartCast® Technology CIF-10V - For use with luminaires with 10V controls when integral SmartCast isn't available T-Bar Clips for Hunter Douglas® Ceilings CR-HDC-1 - Makes the CR troffers compatible with Armstrong XL, USG DX 1-1/2" or USG 1-5/8" T-grids - Allows fixture to hang 1-1/2" below T-grid to be flush with ceiling tiles - One required per luminaire - Includes 4 clips and 8 screws	Cree SmartCast® Technology Configuration Tool CCT-CWC 1 - One required per project when CIF-10V is selected 347 Volt Conversion Kits CR-347V - For use with 10V or LES controls - Not compatible with emergency backup options, surface mount kits or EJBCR-5PK - Maximum operating temperature: 25°C (77°F) CR-347V-SD - For use with S controls - Not compatible with emergency backup options, surface mount kits or EJBCR-5PK - Maximum operating temperature: 25°C (77°F)	Drywall Grid Adaptor DGA24-WHT Junction Box (5-Pack) EJBCR-5PK - Expanded size junction box for through wiring - Not compatible with surface mount kits or 347V adaptor kits 6" Flexible Power Whip PW-18/4-06-9T/SS Surface Mount Kit SMK-24 - Not compatible with EB14 option. When EB14 is required, order as EB14SMK option - Not compatible with 347V adaptor kits or EJBCR-5PK

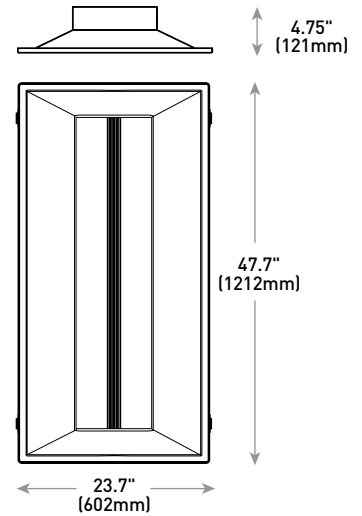

NOTE: Use of Expanded Junction Box will expand the depth to 6.7" (170mm) and Emergency Backup will expand the depth to 6.4" (163mm). Use of integral 347V or 347V conversion kits will increase fixture height by 1.7" (42mm)

Ordering Information

Example: CR24-40L-40K-10V

CR24	Product	Initial Delivered Lumens	CCT	Voltage	Control	Options
CR24	22L 22W, 2,200 lumens – 100 LPW - Available only with 35K or 40K 31L 34W, 3,100 lumens – 90 LPW 40L 40W, 4,000 lumens – 100 LPW 40LHE 30.5W, 4,000 lumens – 130 LPW (30K) 32W, 4,000 lumens – 125 LPW (35K) 33W, 4,000 lumens – 120 LPW (40K) 34.5W, 4,000 lumens – 115 LPW (50K) 50L 50W, 5,000 lumens – 100 LPW	30K 3000K 35K 3500K 40K 4000K 50K 5000K	Blank 120-277 Volt 34 347 Volt - Integrated option available only with 40L and 10V. Other types require addition of a 347 volt accessory kit (see table above) - Maximum operating temperature: 25°C (77°F)	S Step Dimming to 50% 10V 0-10V Dimming to 5% LES ¹ Lutron EcoSystem® Enabled to 5%	CP Chicago Plenum Rated - Not available with 347V or EB14 options or CIF-10V, EJBCR or PW-18/4-06-9T/SS accessories HD ² CRI 80+ - Available only with 40L (44W, 4,000 lumens - 90 LPW) EB14 ³ Emergency Backup - 1400 lumens - Not for use with SMK Kits. Use EB14SMK - Provides 90 minutes of emergency operation - Minimum operating temperature: 10°C (50°F); 20°C (68°F) with HD and EB14 option EB14SMK ⁴ Emergency Backup w/Surface Mount Kit - 1400 lumens - Includes surface mount kit accessory (SMK-CR24) - Provides 90 minutes of emergency operation - Minimum operating temperature: 10°C (50°F)	

1. Not available with 31L or 40LHE 2. Not available with 34 or EB14SMK 3. Not available with 50L, 34 or LES except 40L 4. Not available with 50L, 50K, 34, LESof HD



US: creelighting.com (800) 236-6800

Canada: creelighting-canada.com (800) 473-1234

Product Specifications

CREE TRUEWHITE® TECHNOLOGY

A revolutionary way to generate high-quality white light, Cree TrueWhite® Technology is a patented approach that delivers an exclusive combination of 90+ CRI, beautiful light characteristics, and lifelong color consistency, all while maintaining high luminous efficacy – a true no compromise solution

CREE LIGHTING LED TECHNOLOGY

Cree Lighting's total systems approach to product development is a comprehensive engineering philosophy that combines the most advanced LED sources, driver technologies, optics and forms. The result is highly-reliable luminaire solutions for both indoor and outdoor applications that reduce energy use, extend lifetimes, and maximize illumination performance and quality.

ROOM-SIDE HEAT SINK

An innovative thermal management system designed to maximize cooling effectiveness by integrating a unique room-side heat sink into the diffusing lens. This breakthrough design creates a pleasing architectural aesthetic while conducting heat away from LEDs in a temperature-controlled environment. This enables the LEDs to consistently run cooler, providing significant boosts to lifetime, efficacy, and color consistency.

CONSTRUCTION & MATERIALS

- Durable 22-gauge steel housing with standard troffer access plate for electrical installation
- One-piece lower reflector finished with a textured high reflectance white polyester powder coating creates a comfortable visual transition from the lens to the ceiling plane
- Not for installation within 3" (76mm) of insulation
- Includes t-bar clips and holes for mounting support wires (by others)
- May be surface mounted or suspended w/surface mount kit accessory
- Individual luminaires may be mounted end to end for a continuous row of illumination

OPTICAL SYSTEM

- Unique combination of reflective and refractive optical components achieves a uniform, comfortable appearance while eliminating pixelation and color fringing
- Components work together to optimize distribution, balancing the delivery of high illuminance levels on horizontal surfaces with an ideal amount of light on walls and vertical surfaces. This increases the perception of spaciousness
- Diffusing lens integrated with upward-facing LED strip eliminates direct view of LEDs while lower reflector balances brightness of lens with the ceiling to create a low-glare high angle appearance

ELECTRICAL SYSTEM

- Integral, high-efficiency driver
- **Power Factor:** = 0.9 nominal
- **Input Power:** Stays constant over life
- **Input Voltage:** 120-277V or 347V, 50/60Hz
- **Operating Temperature Range:** 0°C - + 35°C (32°F - + 95°F); 347V: 0°C - + 25°C (32°F - + 77°F); EB14: 10°C - + 35°C (50°F - + 95°F); HD w/EB14: 20°C - + 35°C (68°F - + 95°F)
- **Total Harmonic Distortion:** < 20%
- **10V Source Current:** 0.25mA

CONTROLS

- Step dimming to 50%
- Continuous dimming to 5% with 0-10V DC control protocol. For use with Class 1 or Class 2 dimming systems
- Lutron EcoSystem® Enabled option allows seamless integration with Lutron EcoSystem controls
- Reference www.creelink.com/exLink.asp?70982140Z58R34I26620963 for recommended dimming controls and wiring diagrams

REGULATORY & VOLUNTARY QUALIFICATIONS

- cULus Listed
- Suitable for damp locations
- Designed for indoor use only
- UL924 (EB14 option)
- CCEA approved when ordered with CP option
- DLC qualified versions available. Some exceptions apply. Please refer to <https://www.designlights.org/search/> for most current information
- RoHS compliant. Consult factory for additional details
- Meets FCC Part 15, Subpart B, Class A limits for conducted and radiated emissions
- **CA RESIDENTS WARNING:** Cancer and Reproductive Harm – www.p65warnings.ca.gov

CR Series Ambient Adjusted Lumen Maintenance						
Ambient	Lumen Package	Initial LMF	25K hr Reported ² LMF	50K hr Reported ² LMF	75K hr Estimated ³ LMF	100K hr Estimated ³ LMF
0°C (41°F)	22L, 31L, 40L, and 50L	1.05	1.04	1.04	1.04	1.04
	40LHE	1.05	1.01	0.98	0.96	0.94
5°C (41°F)	22L, 31L, 40L, and 50L	1.04	1.03	1.03	1.03	1.03
	40LHE	1.04	1.00	0.97	0.95	0.93
10°C (50°F)	22L, 31L, 40L, and 50L	1.03	1.02	1.02	1.02	1.02
	40LHE	1.03	0.99	0.96	0.94	0.92
15°C (59°F)	22L, 31L, 40L, and 50L	1.02	1.01	1.01	1.01	1.01
	40LHE	1.02	0.98	0.95	0.93	0.91
20°C (68°F)	22L, 31L, 40L, and 50L	1.01	1.00	1.00	1.00	1.00
	40LHE	1.01	0.97	0.95	0.92	0.90
25°C (77°F)	22L, 31L, 40L, and 50L	1.00	0.99	0.99	0.99	0.99
	40LHE	1.00	0.96	0.94	0.91	0.89
30°C (86°F)	22L, 31L, 40L, and 50L	0.99	0.98	0.98	0.98	0.98
	40LHE	0.99	0.95	0.93	0.91	0.89
35°C (95°F)	22L, 31L, 40L, and 50L	0.98	0.97	0.97	0.97	0.97
	40LHE	0.98	0.94	0.92	0.90	0.88
40°C (104°F)	22L, 31L, 40L, and 50L	0.97	0.96	0.96	0.96	0.96
	40LHE	0.97	0.93	0.91	0.89	0.87

¹ Lumen maintenance values at 25°C (77°F) are calculated per IES TM-21 based on IES LM-80 report data for the LED package and in-situ luminaire testing. Luminaire ambient temperature factors (LATF) have been applied to all lumen maintenance factors.

² In accordance with IES TM-21, Reported values represent interpolated values based on time durations that are up to 6x the tested duration in the IES LM-80 report for the LED.

³ Estimated values are calculated and represent time durations that exceed the 6x test duration of the LED.

Photometry

CR24-40L-30K BASED ON LTL REPORT TEST #: 24421

Luminaire photometry has been conducted in accordance with IES LM-79-08. IES LM-79-08 specifies the entire luminaire as the source resulting in a luminaire efficiency of 100%.

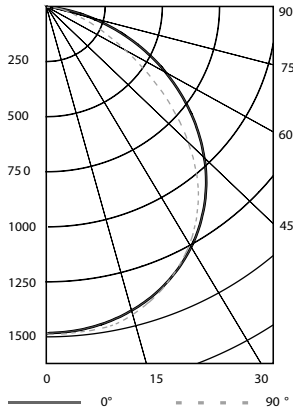

Coefficients Of Utilization – Zonal Cavity Method				
RC %:	80			
RW %:	70	50	30	10
RCR: 0	119	119	119	119
1	109	105	101	97
2	100	92	85	79
3	91	80	72	66
4	83	71	63	56
5	76	64	55	48
6	71	57	48	42
7	65	52	43	37
8	61	47	39	33
9	57	43	35	30
10	53	40	32	27

Effective Floor Cavity Reflectance: 20%

Reference <http://creelighting.com/products/indoor/troffers/cr-series> for detailed photometric data

Average Luminance Table (cd/m²)			
Vertical Angle	Horizontal Angle		
	0°	45°	90°
45°	1,976	2,116	2,152
55°	1,807	2,018	2,074
65°	1,553	1,889	1,879
75°	1,149	2,348	1,119
85°	424	62	62

Zonal Lumen Summary			
Zone	Lumens	% Lamp	Luminaire
0-30	1,115	27.9%	27.9%
0-40	1,835	45.9%	45.9%
0-60	3,245	81.1%	81.1%
0-90	4,000	100%	100%
0-180	4,000	100%	100%

Application Reference

Based on CR22-40L-30K Luminaire

Open Space						
Spacing	Initial Delivered Lumens	Lumens	Wattage	LPW	w/ft²	Average fc
8 x 8	22L	2200	22	100	0.35	30
	40L	4000	40	100	0.69	54
	40LHE	4000	30.5	125	0.56	54
	50L	5000	50	100	0.78	68
8 x 10	22L	2200	22	100	0.28	25
	40L	4000	40	100	0.55	45
	40LHE	4000	30.5	125	0.45	45
	50L	5000	50	100	0.62	57
10 x 10	22L	2200	22	100	0.22	21
	40L	4000	40	100	0.44	38
	40LHE	4000	30.5	125	0.36	38
	50L	5000	50	100	0.50	48
10 x 12	22L	2200	22	100	0.19	17
	40L	4000	40	100	0.37	30
	40LHE	4000	30.5	125	0.30	30
	50L	5000	50	100	0.42	38

9' ceiling: 80/50/20 reflectances; 2.5' workplane, open room. LFL: 1.0 Initial Open Space: 50' x 40' x 9'

© 2020 Cree Lighting, A company of IDEAL INDUSTRIES. All rights reserved. For informational purposes only. Content is subject to change. Patent www.creelighting.com/patents. Cree®, the Cree logo, TrueWhite®, Cree TrueWhite® and the Cree TrueWhite Technology logo are registered trademarks of Cree, Inc. SmartCast® is a registered trademark, and CR24™ is a trademark of Cree Lighting, A company of IDEAL INDUSTRIES. The UL logo is a registered trademark of UL LLC. Lutron®, Lutron EcoSystem®, EcoSystem®, and the Lutron EcoSystem Enabled logo are registered trademarks of Lutron, Inc. The DLC QPL logo is a registered trademark of Efficiency Forward, Inc. Hunter Douglas® is a registered trademark of Hunter Douglas International, N.V. Corporation.