



GNSS/GPS Signals Over Single Mode Fibre Optic Cables

CONTENTS

Introduction	3
GPS Over Fibre - Overview	4
GPS Over Fibre - DC Considerations	6
VialiteHD Blue OEM Link	7
Calculating Fibre Link Gain	9
Calculating Fibre Link Signal Latency	10
Ordering Information	11
Application Example	14
Contact Details	15



Introduction

The signal input to a GPS repeater (or any other type or receiver) is usually provided by a roof-mounted antenna and a length of coaxial cable.

The active antenna has a built-in low noise amplifier (LNA) to overcome losses through attenuation through the cable. A typical antenna gain factor is 35 to 40dB.

The DC voltage required to power the LNA is derived from the GPS repeater through the coaxial cable. The repeater supplies 5V DC. The voltage supplied by other devices can vary between 3V and 15V DC.

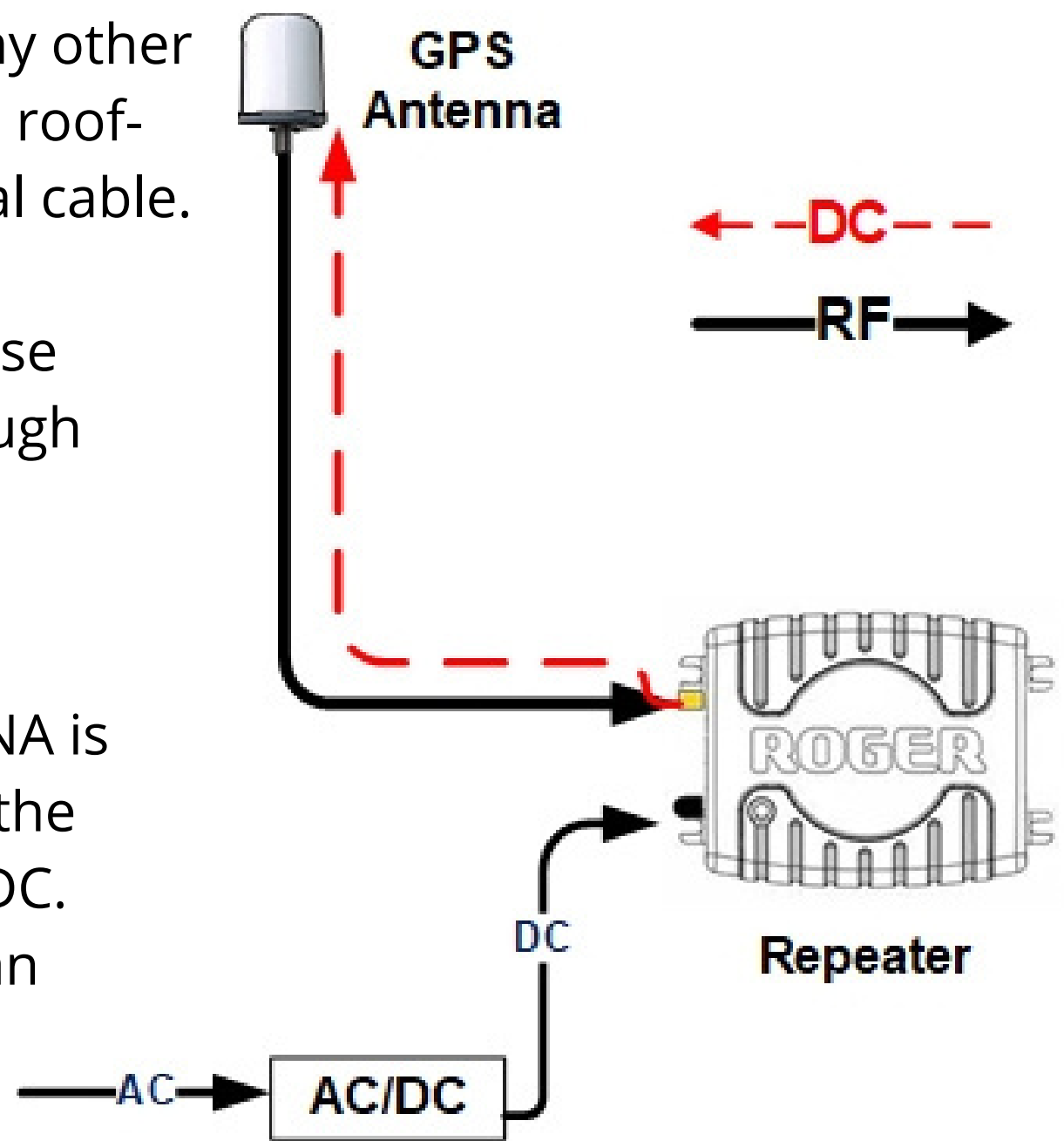

FalTech provides GPS repeater kits with typical cable lengths of 10m to 40m, using RF240 low-loss coaxial cable.

When the distance from roof antenna to repeater is more than 40 meters, the negative effects of signal loss through attenuation can be countered by upgrading the cable type to RF400 and/or the inclusion of an inline amplifier.

The inline amplifier inserts 10 - 20dB of signal gain and passes the DC voltage straight through from repeater to the antenna.

The amplifier uses some of the DC current to power itself, typically <10mA.

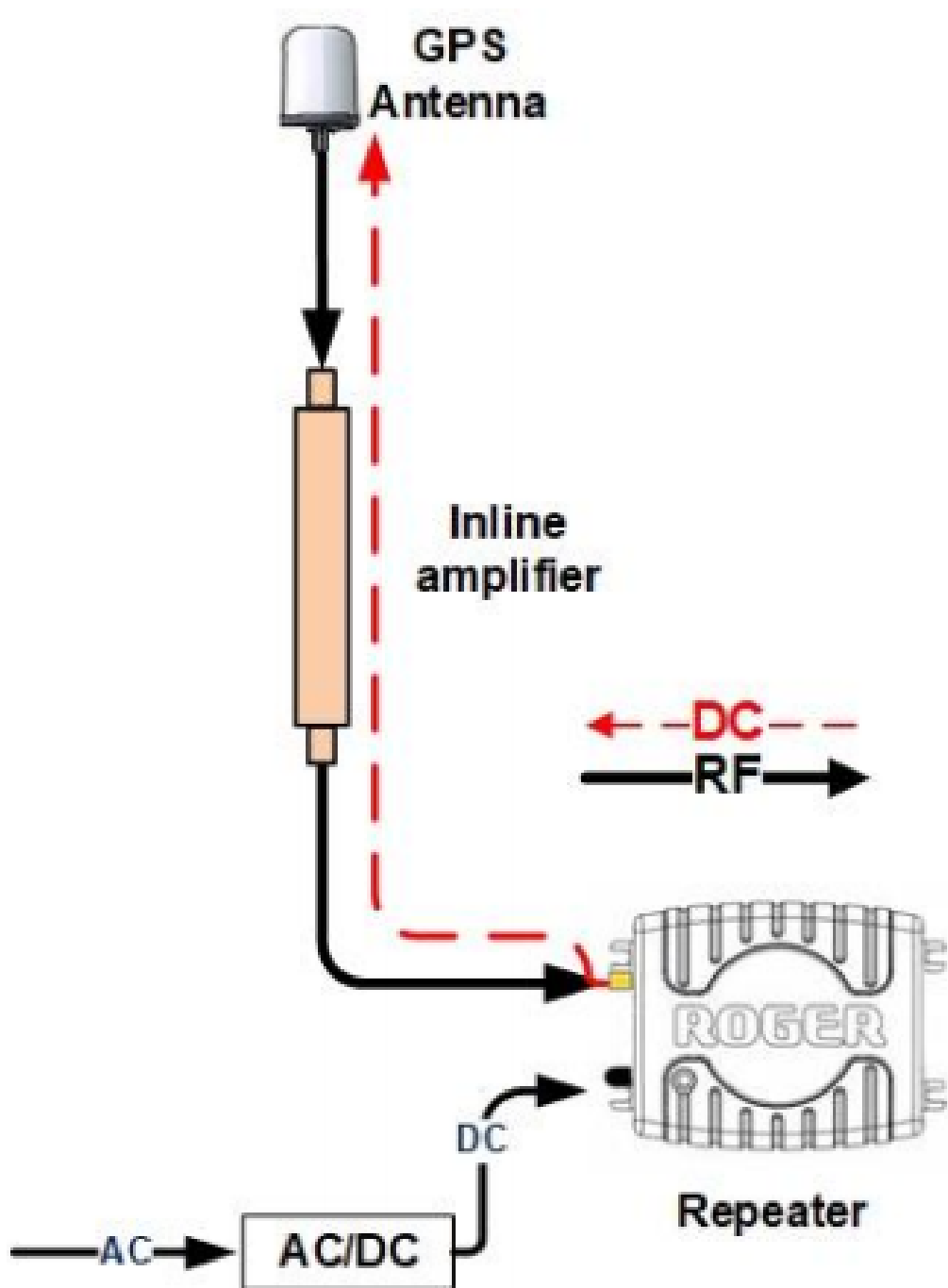



Coaxial Cable Limitations:

- In-line amplifiers and up-rated cable can be used to overcome signal losses caused by attenuation but may introduce unwanted noise and distortion.
- Low-loss cable is often several millimetres in diameter (RF400 is ~11mm outer diameter) and is heavy and difficult to install over long distances.
- Good quality low-loss coaxial cable can be expensive.
- Even when using a well-screened cable, the signal can be affected by electromagnetic interference (EMI), especially if it is positioned near power lines.
- Coaxial cables can be adversely affected by temperature changes, severe weather (especially lightning) and moisture.

Any, or all, of these factors, may mean that it becomes impractical continually to increase the cable length.

GPS Over Fibre - Overview

GPS over Fibre technology extends the range of a GPS antenna feeder cable well beyond what is achievable by use of coaxial cables.

Signal losses through attenuation can limit the range of a coaxial cable-based system to perhaps 100 meters when using low-loss cable and amplifiers, whereas an optical fibre system can increase reach to several kilometers if required.

- Signal loss through attenuation is much smaller compared to the same length of coaxial cable.
- Optical fibre is immune to the effects of electromagnetic interference (EMI) and can be installed in environments that would not be suitable for copper cables.



- An optical fibre cable, even one with many cores inside the outer sheath, is smaller and lighter than coaxial cable.
- Fibre optic cable is relatively inexpensive and easy to install.

A GPS receiving antenna is placed outside the building, preferably at roof level, where it has a clear view of the sky to ensure it can “see” as many satellites as possible.

A low-loss coaxial cable (C1) connects the antenna to the TX unit.

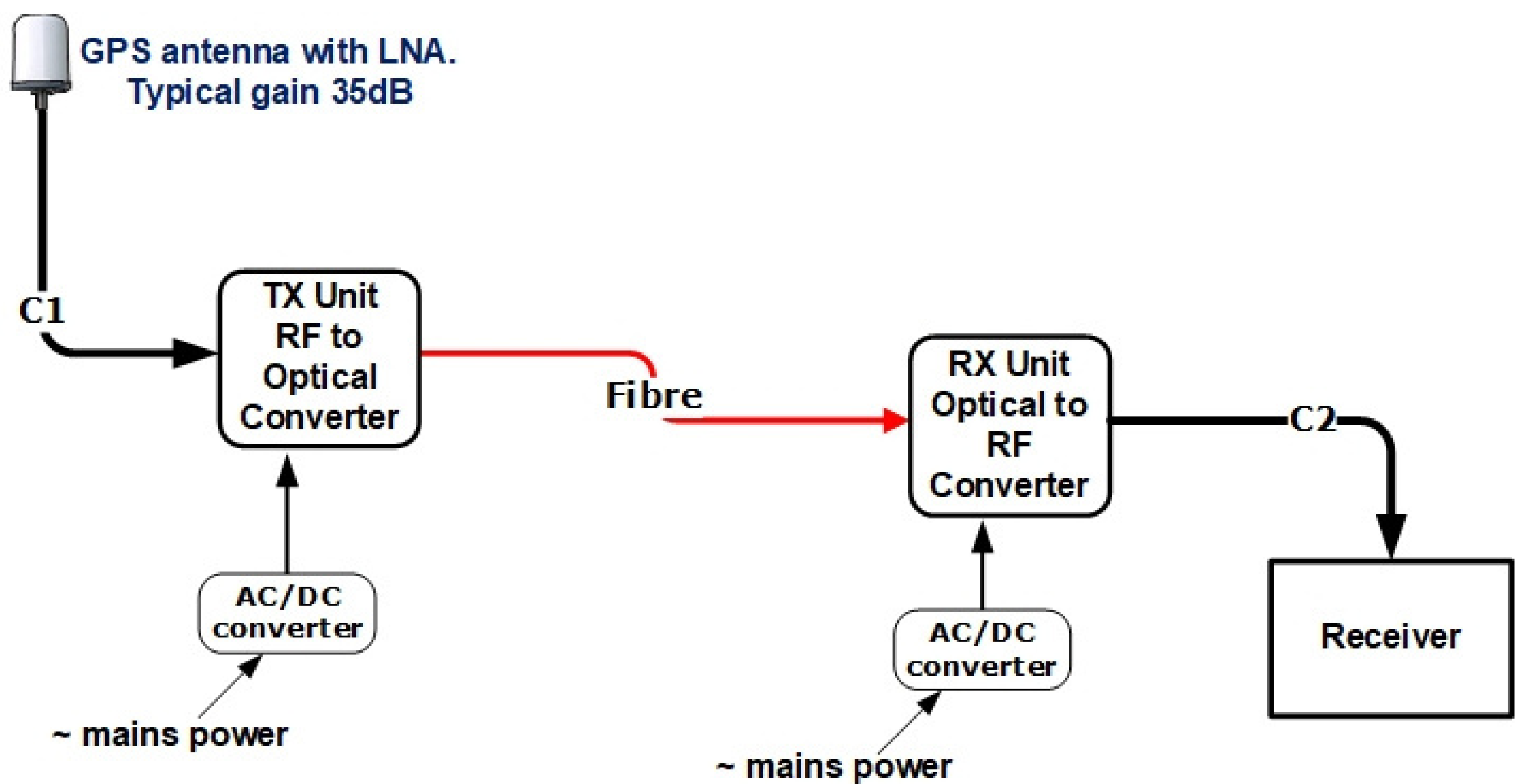

To ensure the input signal to the TX unit is as noise-free as possible, and to keep losses through attenuation to a minimum, it is recommended to keep this cable as short as practically possible.

The TX unit is usually placed indoors, near an AC outlet - a riser or other suitable structure is ideal.

Alternatively, it can be installed outside the building, inside a suitable waterproof enclosure.



The transmitter module converts the RF signals into light by modulating a laser light source; the modulated light is then transported through an optical fibre to the optical receiver (RX) module.

The RX unit converts the light signal back into its original RF form, then amplifies and impedance matches it to the attached GPS receiver/repeater.

GPS Over Fibre - DC Considerations

The outdoor antenna requires DC current for its internal low-noise amplifier (LNA), as described in section 1.

As optical fibre is not conductive, it is necessary to ensure the antenna receives a DC supply in the same way as it would when directly connected to the receiver by coaxial cable.

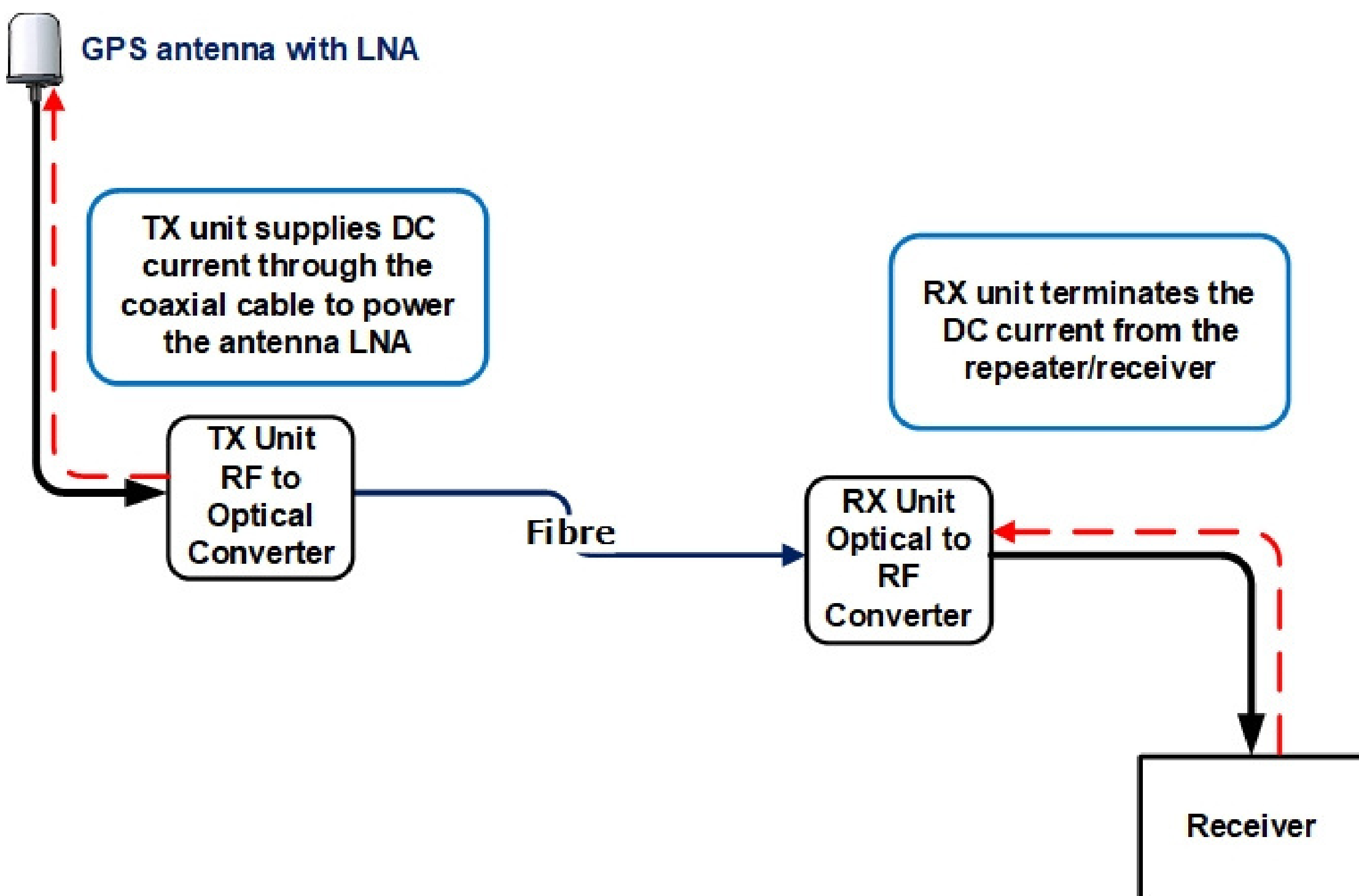

The optical TX unit provides a DC supply to the LNA in the antenna, while the optical RX unit absorbs the DC supply from the attached repeater /receiver.

VialiteHD Blue OEM Link

FalTech recommends the **VialiteHD Blue OEM** system for extending GPS signals over single mode fibre.

The VialiteHD Blue optical extenders are supplied as a "TX/RX pair".

The TX and RX units look physically the same, measuring 89 x 46 x 20mm.

The RF connector is **SMA** with an **SC/APC** or **FC/APC** optical connector.

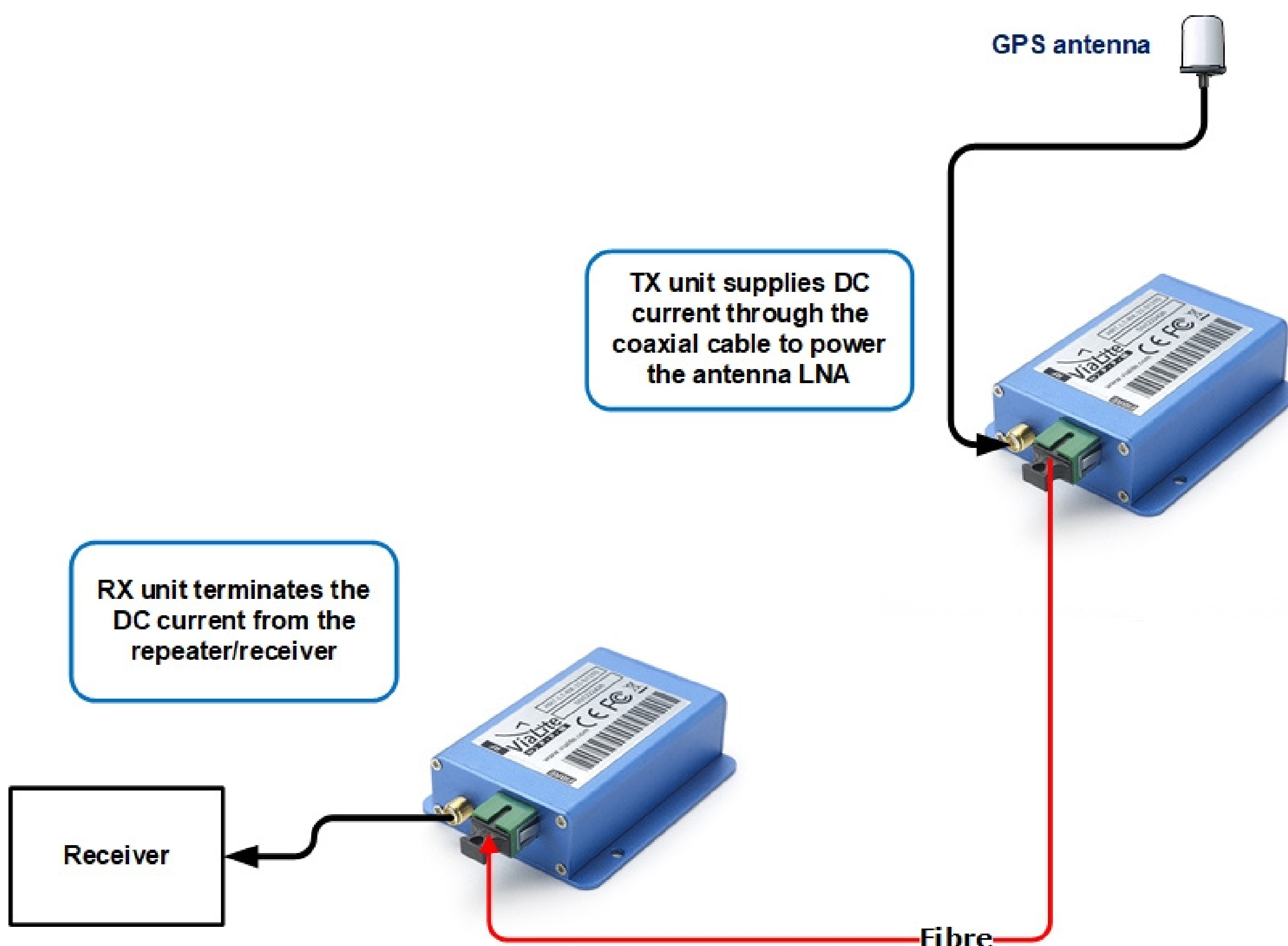



Depending on the type of laser installed in the TX unit, the distance from antenna to receiver can be up to 20km over single mode fibre. The VialiteHD Blue OEM has a built-in monitoring system that provides alerts under certain failure scenarios.

TX Unit Monitoring

The transmitter monitors the DC current flowing from its RF connector to the active GPS antenna.

If the antenna fails or is disconnected, and the current drawn by the active antenna falls below an alarm threshold of 10mA, the unit will switch off the laser light source. The status LED shows red to indicate an antenna fault.

This serves to protect the laser and increase its lifespan by preventing it from transmitting needlessly when there is no RF signal input.

The subsequent loss of received light at the RX unit will cause an alarm in the connected repeater/receiver device.

RX Unit Monitoring

Under normal conditions, the RX unit presents a DC load at its RF connector to simulate the presence of an GPS antenna.

For antenna bias voltages in the range of 5 to 24V, this typically sinks 15mA of current.

Under fault conditions, for example RX unit failure or low received light levels from the remote TX, the DC load is removed from the circuit and the status LED shows red.

The open circuit connector indicates to the receiver that the antenna is not present and will cause an alarm indication in most GPS receivers and time servers.



Calculating Fibre Link Gain

To ensure that the attached receiver/repeater has a GPS signal input that is within the required tolerances, the overall link gain must be calculated.

Each component in the link from antenna to receiver input inserts an RF gain or a loss factor that is used to calculate the overall gain or loss.

Example Of Optical Link Gain

Antenna is typically a Tallysman TW3742 with 38dB gain.

Cable 1, typically RF240, 10 meters, loss -3.5dB.

VialteHD TX unit inserts -5dB loss.

Single mode fibre with 1310nm laser: optical loss is -0.4dB/km, while RF loss is 0.8dB/km.

Single mode fibre with 1550nm laser: optical loss is -0.2dB/km, while RF loss is -0.4db/km.

VialteHD TX unit inserts +5dB gain.

Cable 2, typically RF240, 10 meters, loss -3.5dB.

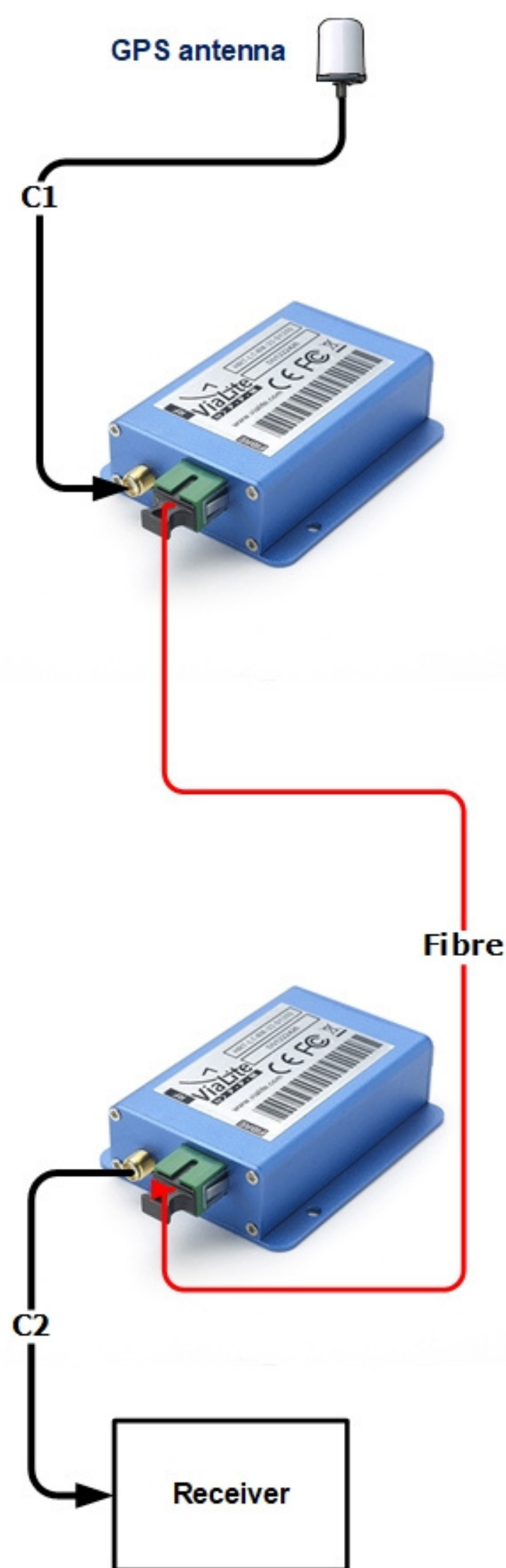



Example optical link gain

Antenna	+38
C1	-3.5
TX unit	-5
100m fibre @1310nm	-0.08
RX unit	+5
C2	-3.5
Total link gain	+31dB

A Roger-GPS repeater needs a minimum link gain of +16dB, so this example would work well.

When connecting to any other GNSS/GPS receiver, refer to the specifications in the device manual to make sure that this is within its expected range.

Calculating Fibre Link Signal Latency

Example optical link latency

Antenna LNA	36 nS
C1, RF240, 10 meters (3.97 nS / meter)	39.7nS
Optical TX unit	6.75 nS
Optical fibre (100m @ 1310nm)	500 nS
Optical RX unit	6.75nS
C2, RF240, 10 meters (3.97 nS / meter)	39.7nS
Total link latency	628.9 nS

As signal propagates through all the devices in the path from outdoors to receiver input, it incurs a delay. It is important to know this delay (latency), especially in a PNT (**P**osition, **N**avigation and **T**iming) environment.

The latency figure can be entered into the PNT device to improve its accuracy, even though the latency is usually measured in nanoseconds.

Using the same example as shown in the optical link gain budget, a latency calculation would look like this.



Ordering Information

There are many options available when specifying the VialiteHD Blue OEM units.

In the context of a GPS antenna feeder extender, the following example configuration is one of the most commonly used.

Optical TX Ordering Code

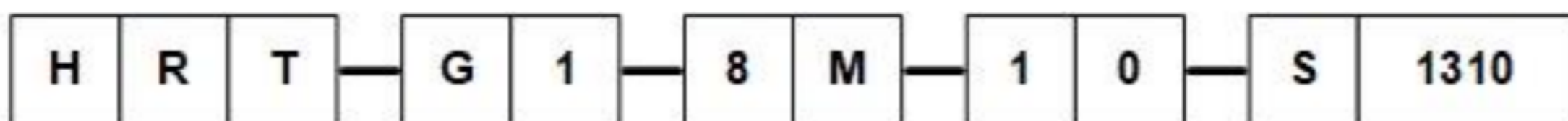

H = VialiteHD range

R = VialiteHD range

T = Module type (Transmitter)

G = Frequency (GPS 1 GHz to 1.8 GHz)

1 = Electrical connector (SMA, 50 ohm)

8 = Optical connector (single mode SC/APC)

M = Module type (Blue Link)

1 = Option (+5V DC feed out of TX RF connector)

0 = TX gain (-5dB)

S = TX laser type (DFB, standard, 3mW +/- 20nm)

1310 = laser wavelength (nm)



Optical RX Ordering Code

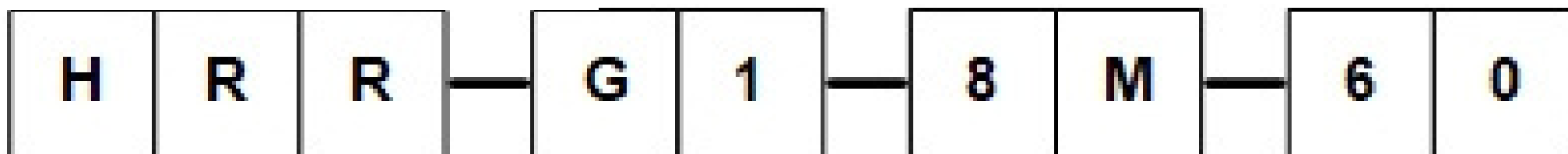

H = VialiteHD range

R = VialiteHD range

R = Module type (Receiver)

G = Frequency (GPS 1 GHz to 1.8 GHz)

1 = Electrical connector (SMA, 50 ohm)

8 = Optical connector (single mode SC/APC)

M = Module type (Blue Link)

6 = Option (GPS load simulator for +5V bias)

0 = RX gain (+5dB)

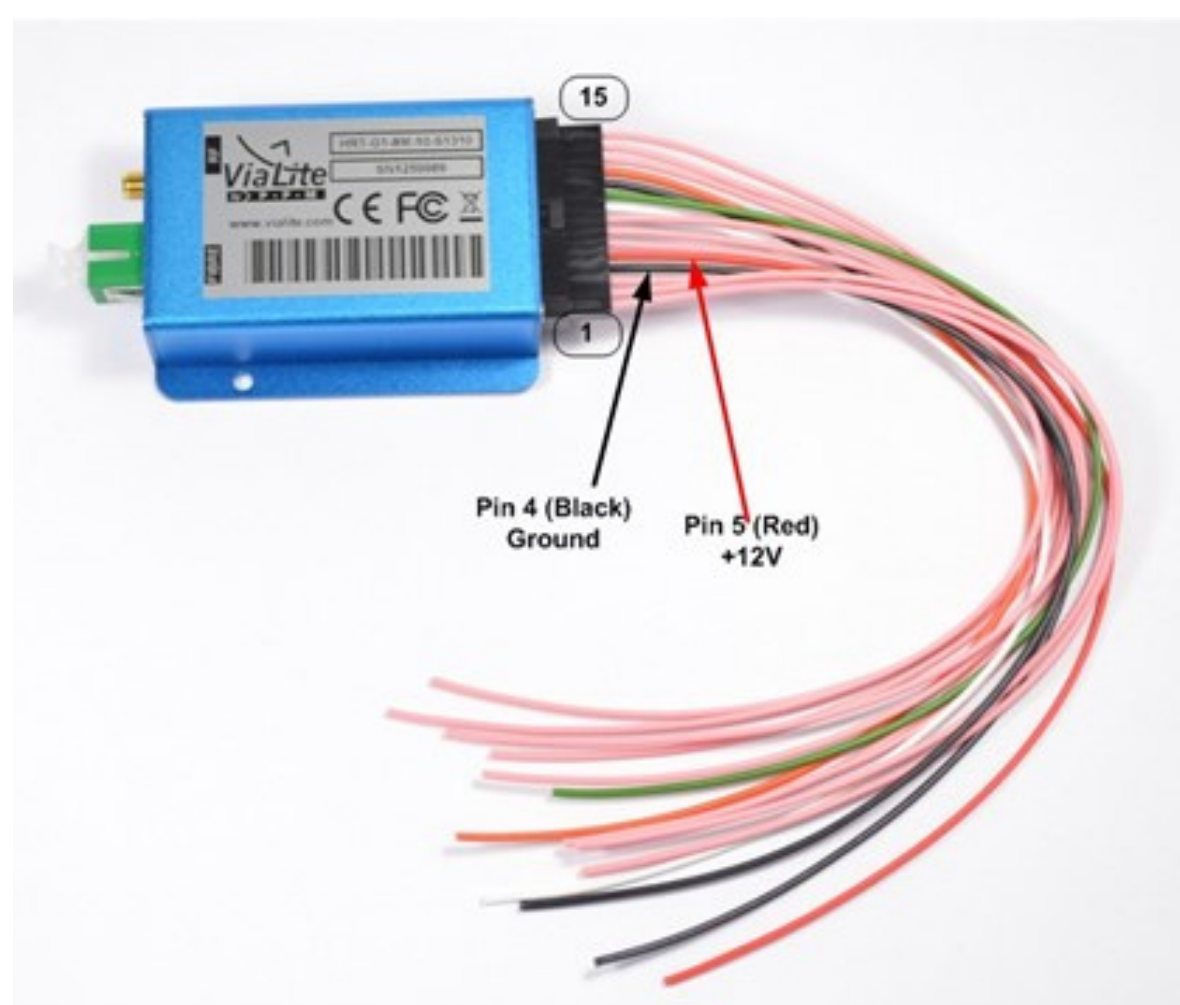

The TX and RX modules can be integrated into a larger communications system. They are supplied with a 15-pin Molex connector that leaves the integrator free to connect DC power and any monitoring outputs required for their system.

The photo above shows pins 4 & 5 are used for DC power; the other connectors provide various telemetry signals for remote management purposes.



If the monitoring signals are not required there are two options:

Option 1 – Connect the DC +ve and -ve wires to a suitable power supply and cut off the unused/unwanted wires. Or leave them intact and tidy them out of the way in case they are needed in future.

Option 2 – Alternatively, the TX/RX units can be supplied with an external power supply unit that doesn't provide access to the monitoring outputs.



AC/DC power supply (HPS-CS-3) with mounting bracket



Application Example

VialiteHD Link With Local Lossless Splitter Chassis

An optical link can be used to extend GPS signal to many receivers, for example in a data centre environment.

A TX unit transfers the RF signal to the fibre by modulating the RF signal onto light.

In the data centre, the RX unit is installed inside the splitter chassis, providing up to 16 RF outputs per optical link.

The RX unit gain can be set, for example, to +25 dB to overcome the losses incurred when splitting the GPS signal between 16 RF connections.

The 1RU chassis has dual redundant power supplies, with optional SNMP.

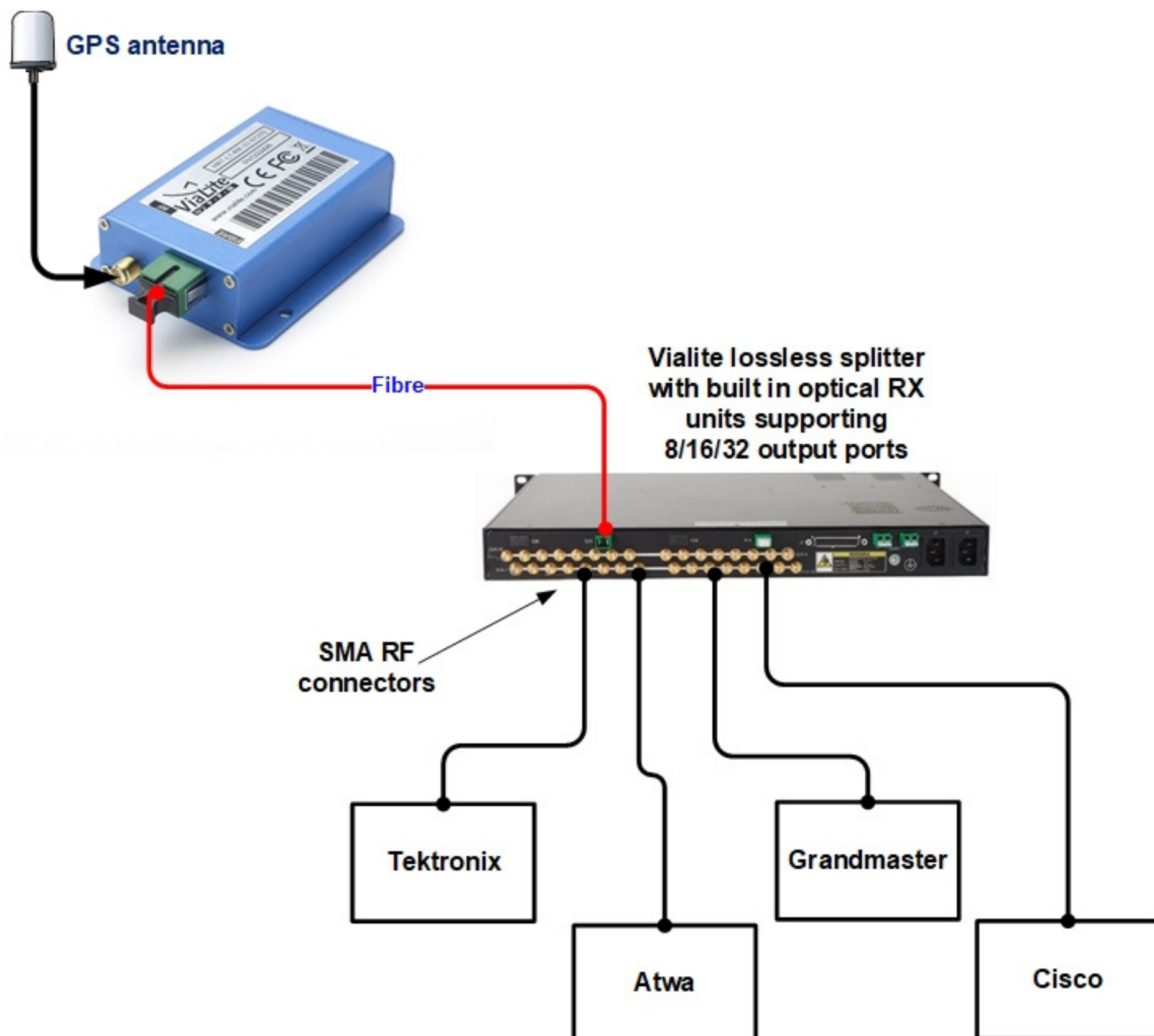



Contact Details

If you would like any further information about GPS-over-fibre solutions, please get in touch.

FalTech GPS
Unit 6A Waterside House
Falmouth Road
Penryn
TR10 8BE
United Kingdom

[+44 \(0\) 1326 336444](tel:+44(0)1326336444)

info@gps-repeaters.com

www.gps-repeaters.com