

- HOSEBED CAPACITIES
- ① 250' OF 2.50" D.J. HOSE
 - ② 500' OF 4.00" L.D. HOSE
 - ③ 500' OF 4.00" L.D. HOSE

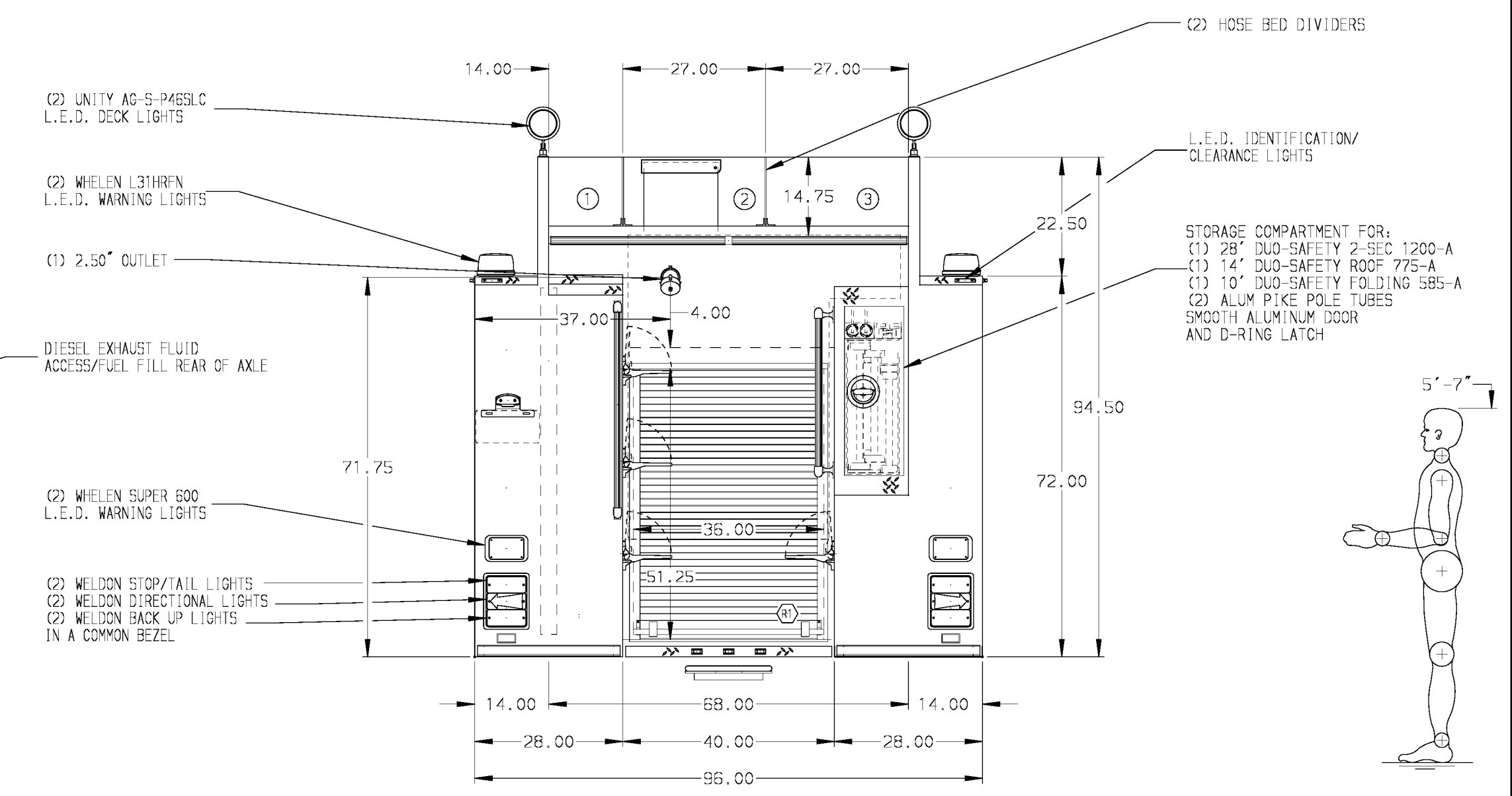

ALUMINUM BODY

NOTE
 DIMENSIONS SHOWN ARE APPROXIMATE AND ARE SUBJECT TO MINOR DEVIATIONS AS MAY OCCUR OR BE NECESSARY IN CONSTRUCTION.
 MINOR DETAILS NOT SHOWN.

1. ALUMINUM TREADPLATE EXTERIOR REAR WALL OF CAB
2. BATTERY CHARGER LOCATED BEHIND DRIVER SEAT
3. BATTERY CHARGER INDICATOR IN D.S. STEP WELL
4. SUB-FEED CIRCUIT BREAKER PANEL IN COMPARTMENT D1
5. 5/8" STL PROTECTIVE GUARD FOR ROLL-UP DOOR IN COMPARTMENT D1, D2, D3, P1, P2, P3, RT
6. PIERCE L.E.D. DUAL COMPARTMENT LIGHT STRIPS LOCATED PER SHOP ORDER
7. SHELF TRACK LOCATED IN COMPARTMENT D1, D2, D3, P1, P2, P3, RT
8. ONE ADJUSTABLE SHELF FULL DEPTH/FULL WIDTH IN COMPARTMENT PER SHOP ORDER
9. ONE ADJUSTABLE TILT/SIDE-OUT BRUSHED ALUMINUM TRAY IN COMPARTMENT PER SHOP ORDER
10. ONE FLOOR MOUNTED SLIDE-OUT TRAY IN COMPARTMENT PER SHOP ORDER
11. CIRCUIT BREAKER PANEL IN COMPARTMENT D1
12. (1) 120V TWIST-LOCK RECEPTACLE ON PUMP PANEL EACH SIDE
13. (2) 120V DUPLEX RECEPTACLES IN EMS COMPARTMENT
14. AIR INLET WITH DISCONNECT COUPLING ON D.S. PUMP PANEL

		JOB NO.	28263
		SCALE	DATE
Pierce MANUFACTURING INC.		TITLE	1500-D-1000P, 161", FULL HEIGHT & DEPTH D.S. FOLDER P.S., (3) X-LAYS, DELUGE, GENERATOR
FOR FLUSHING FIRE DEPARTMENT FLUSHING, MICHIGAN		DRAWN BY	JWO 04SEP14
DWG NO. 28263AD		CHECKED BY	MNE 04SEP14
SHEET NO. 1 OF 1		SHEET SIZE	D

REV	DATE	BY	CH	SABER
09JAN15	JCH	CAG		
05DEC14	JAF	CAG		