

HOSEBED CAPACITIES

①	300' OF 3.00" D.J. HOSE
②	1000' OF 5.00" D.J. HOSE
③	300' OF 3.00" D.J. HOSE

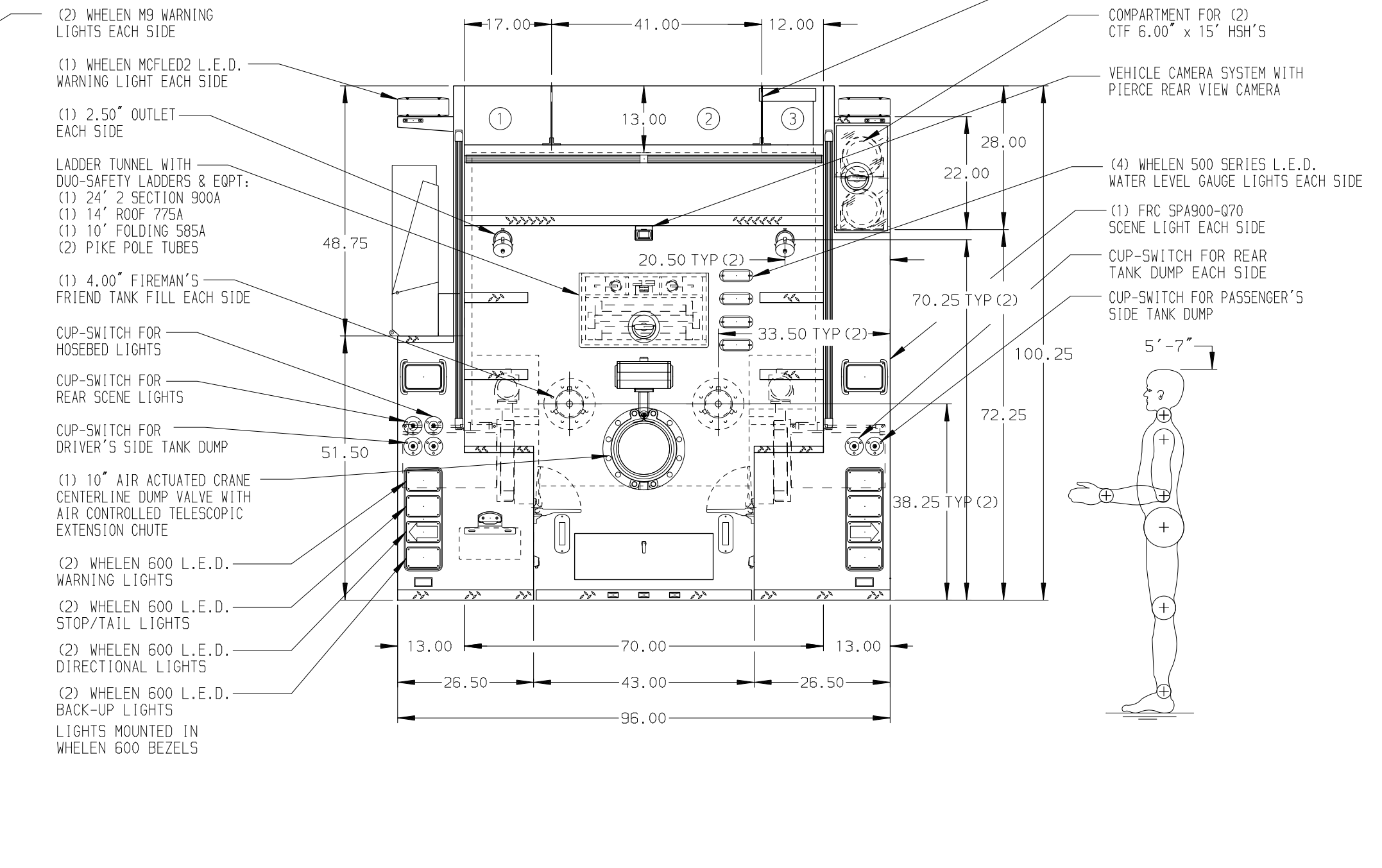
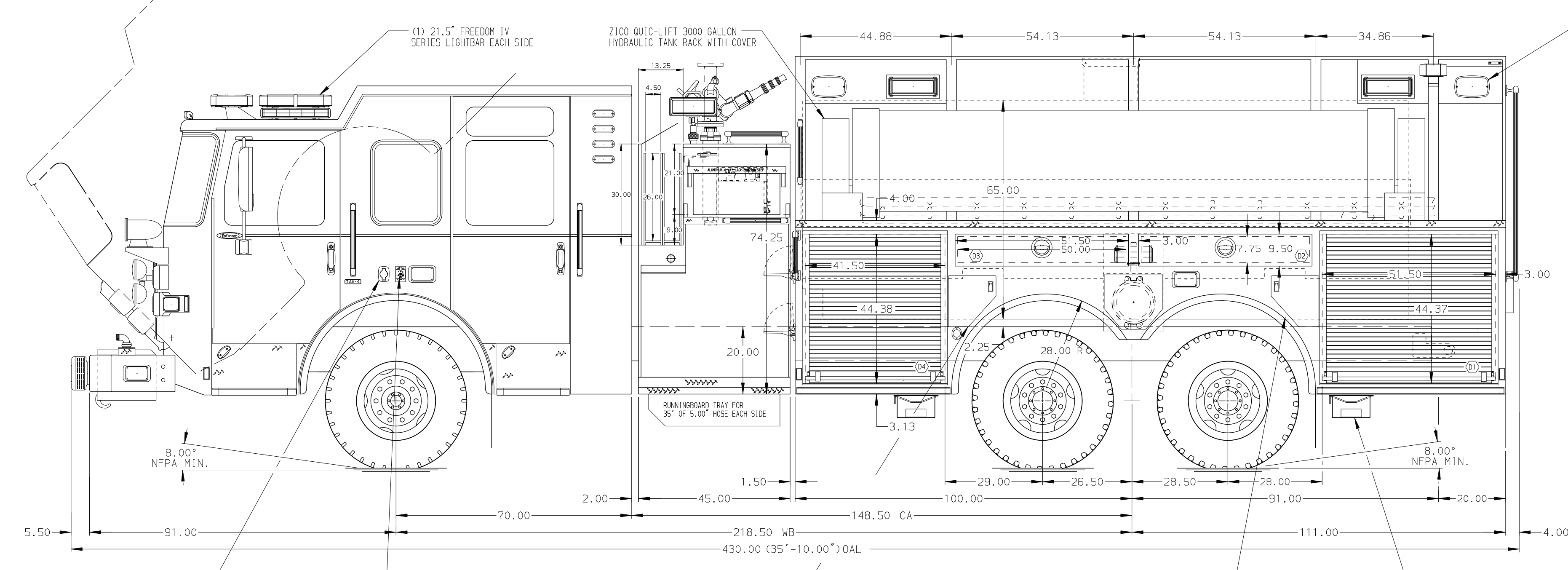

ALUMINUM BODY

SIDE ROLL AND FRONTAL IMPACT PROTECTION

NOTE
DIMENSIONS SHOWN ARE APPROXIMATE AND ARE SUBJECT TO MINOR DEVIATIONS AS MAY OCCUR OR BE NECESSARY IN CONSTRUCTION. MINOR DETAILS NOT SHOWN.

- BATTERY CHARGER LOCATED BEHIND DRIVER SEAT
- BATTERY CHARGE INDICATOR LOCATED ON DRIVER'S SEAT RISER
- DUAL L.E.D. LIGHT STRIPS LOCATED IN HOSE BED
- DRIP PAN GUARD ON ALL ROLL-UP BODY COMPARTMENT DOORS
- CIRCUIT BREAKER PANEL IN COMPARTMENT D4
- GROVER TRAIN HORN LOCATED BEHIND FRONT BUMPER

REV	DATE	BY	CH	ENFORCER
1	18MAY17	AMI	DTS	CHASSIS DATA
2	14APR17	AMI	DTS	MAKE
3	20MAR17	AMI	DTS	PIERCE
4	01MAR17	AMI	CSH	MODEL

		JOB NO.	30976
		SCALE	1:24
TITLE 1500-D-2500 GAL POLY, 211" 3/4 HGT BROOM DS, FH PS SIDE CONTROL, (2) XLAYS, LADDERS THRU TANK, DELUGE	FOR CHRISTIANA FIRE COMPANY CHRISTIANA, PENNSYLVANIA	DATE	
		DRAWN BY	AMI
DWG NO. 30976AD	CHECKED BY CSH	DATE	22FEB17
		SHEET SIZE	D
		SHEET NO.	1 OF 1