

- HOSEBED CAPACITIES**
- ① - 350' OF 1.75" D.J. POLY HOSE
  - ② - 600' OF 3.00" D.J. POLY HOSE
  - ③ - 900' OF 4.00" D.J. POLY HOSE
  - ④ - 900' OF 4.00" D.J. POLY HOSE
  - ⑤ - 250' OF 2.00" D.J. POLY HOSE
  - ⑥ - 250' OF 2.50" D.J. POLY HOSE

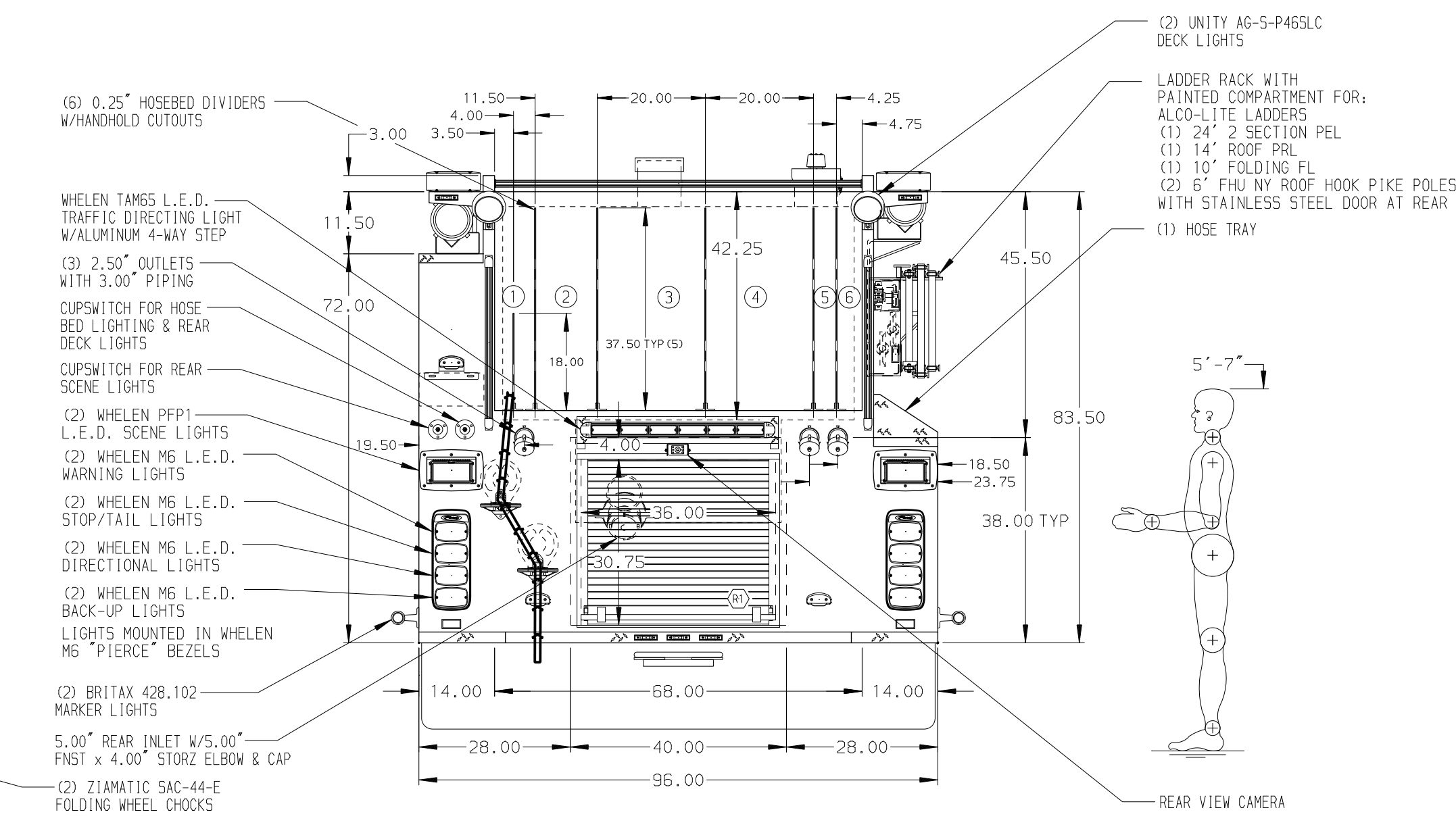
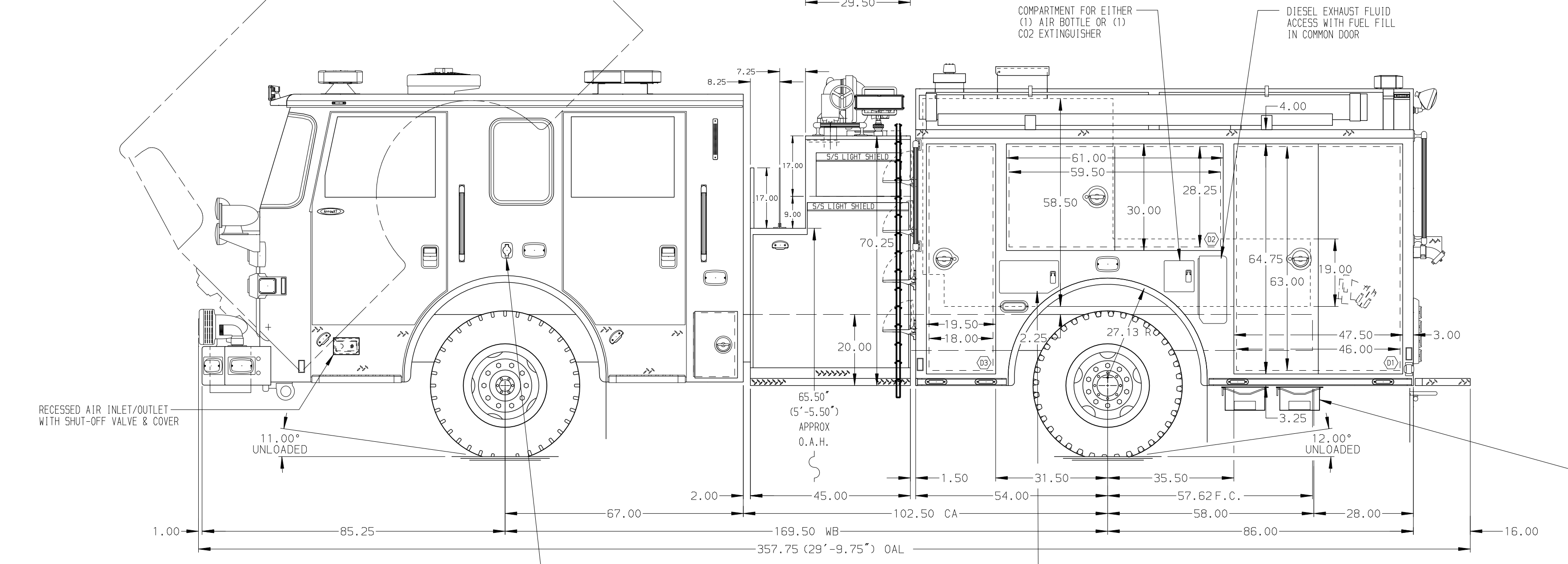

ALUMINUM BODY    MAXIMUM O.A.L. 357.75"    MAXIMUM O.A.H. 115.75"    SIDE ROLL PROTECTION    FRONTAL IMPACT PROTECTION

**NOTE**  
 DIMENSIONS SHOWN ARE APPROXIMATE AND ARE SUBJECT TO MINOR DEVIATIONS AS MAY OCCUR OR BE NECESSARY IN CONSTRUCTION. MINOR DETAILS NOT SHOWN.

- 1. ONSPOT AUTOMATIC TIRE CHAINS TO BE PROVIDED AT REAR
- 2. VOGEL LUBE SYSTEM PUMP LOCATED PER SHOP ORDER
- 3. BATTERY CHARGER LOCATED BEHIND DRIVER'S SEAT
- 4. TWO ADJUSTABLE FULL WIDTH/FULL DEPTH SHELVES IN COMPARTMENT D3 & ONE IN D1, P2, AND R1
- 5. ALUMINUM TREADPLATE ON FLOOR OF COMPARTMENTS D1, D2, D3, P1, AND P2
- 6. MARINE GRADE .75" PLYWOOD ON BACK WALL OF COMPARTMENT D2
- 7. ONE 15A /120V RECEPTACLE LOCATED IN COMPARTMENTS P1 AND P2

REV	DATE	BY	CH	ARROW-XT	CHASSIS DATA	TITLE
23AUG17	GVH	TWH			MAKE	1500-D-750GAL WATER, 25G FOAM CELL, 140" FDLER BODY (2)XLAYS, LADDERS ON SIDE, HUSKY FOAM, DELUGE
28JUL17	GVH	TWH			PIERCE	FOR KENSINGTON VOLUNTEER FIRE DEPARTMENT KENSINGTON, MARYLAND
16JUN17	GVH	WKL			MODEL	DWG NO. 31343AD

**Pierce MANUFACTURING INC.**

JOB NO. 31343  
 SCALE 1:24  
 DATE  
 DRAWN BY GVH  
 12JUN17  
 CHECKED BY WKL  
 12JUN17  
 SHEET SIZE D  
 SHEET NO. 1 OF 1