

- HOSEBED CAPACITIES
- ① 400' OF 2.50" D.J. HOSE
  - ② 1400' OF 5.00" D.J. HOSE
  - ③ 400' OF 2.50" D.J. HOSE

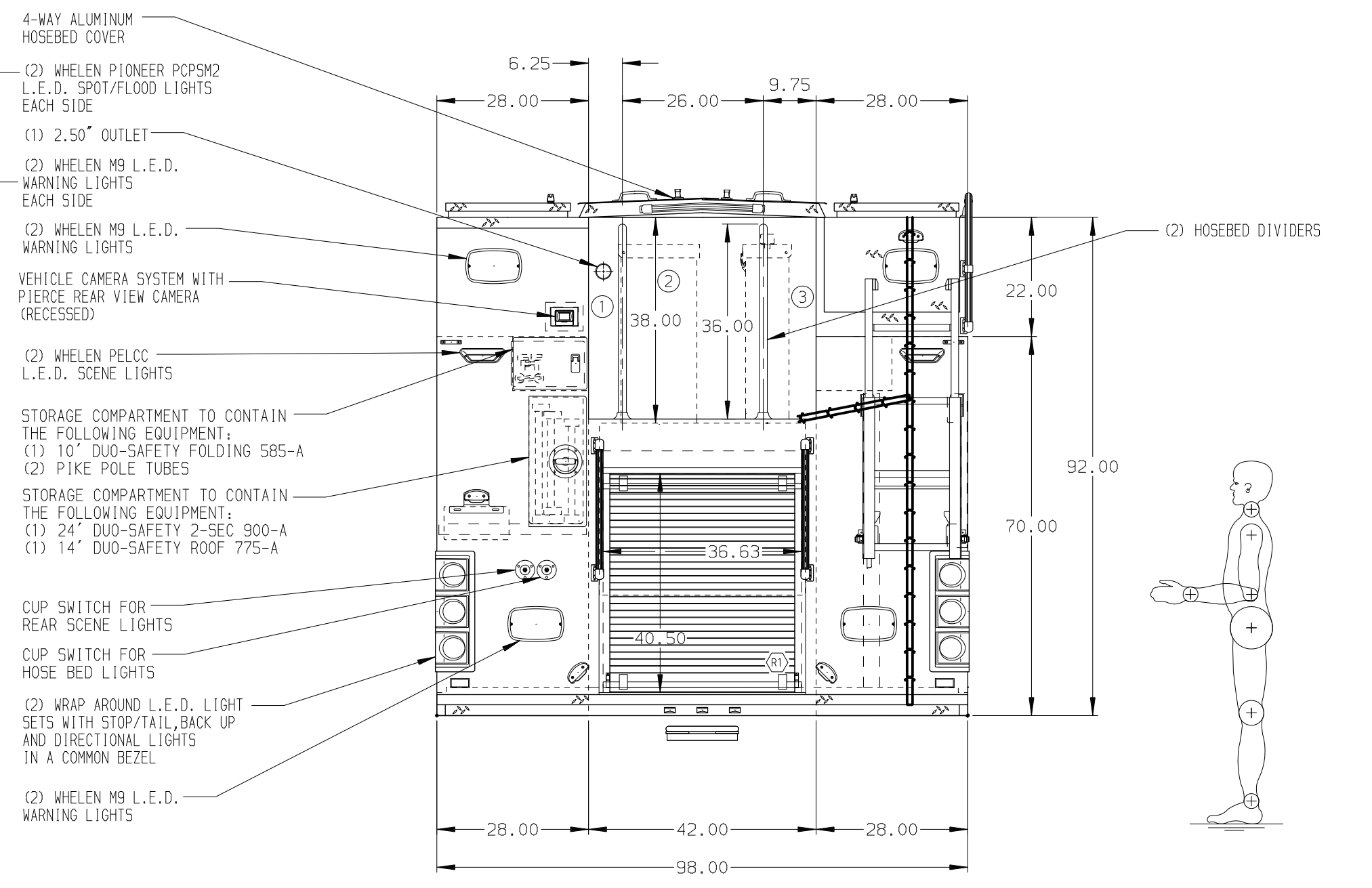
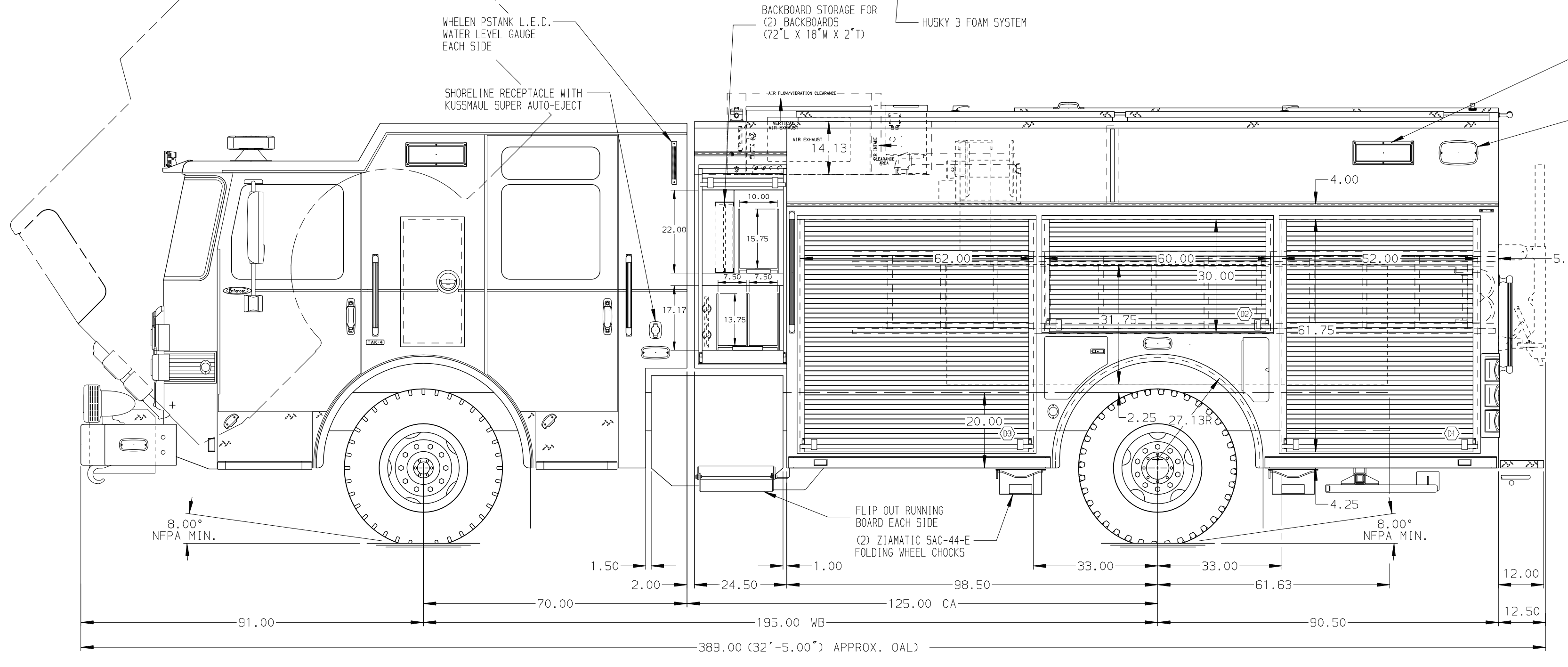

ALUMINUM BODY SIDE ROLL & FRONTAL IMPACT PROTECTION

**NOTE**  
DIMENSIONS SHOWN ARE APPROXIMATE AND ARE SUBJECT TO MINOR DEVIATIONS AS MAY OCCUR OR BE NECESSARY IN CONSTRUCTION. MINOR DETAILS NOT SHOWN.

1. BATTERY CHARGER/COMPRESSOR LOCATED IN DRIVER SIDE HATCH COMPARTMENT
2. BATTERY CHARGE INDICATOR LOCATED ON DRIVER'S SEAT RISER
3. TWO FULL WIDTH ADJUSTABLE SHELF LOCATED IN COMPARTMENTS D1,P1,P3
4. TWO ADJUSTABLE TILT/SLIDE-OUT FULL WIDTH/DEPTH TRAY IN COMPARTMENT P2
5. ONE FLOOR MOUNTED SLIDE-OUT TRAY IN COMPARTMENTS D1,P1,P3,R1
6. TWO SLIDE-OUT TOOLBOARDS WITH PEGBOARD PATTERN IN COMPARTMENT P3
7. ONE SWING-OUT ALUMINUM TOOL BOARD IN COMPARTMENT D2
8. ONE VERTICAL PARTITION LOCATED IN COMPARTMENTS P1,P3
9. CIRCUIT BREAKER PANEL IN COMPARTMENT D3
10. ONE AKRON ERWC-15-10 CORD REEL WITH 200' OF 10/3 CABLE LOCATED IN HATCH COMPARTMENT OVER D3

		JOB NO.	31524
		SCALE	01-03
<b>MANUFACTURING INC.</b>		DATE	04AUG17
		DRAWN BY	JWO
<b>TITLE</b> 1500-D-500P W/25 GAL. FOAM CELL, DELUGE, GENERATOR 189" PUC RESCUE BODY, LADDERS THRU BODY		CHECKED BY	CDU
		SHEET SIZE	D
<b>FOR</b> SOUTH CHARLESTON FIRE DEPARTMENT SOUTH CHARLESTON, WEST VIRGINIA		SHEET NO.	1 OF 1
		DWG NO.	31524AD

160CT17	JWO	MSA	MAKE	CHASSIS DATA
26SEP17	JWO	MSA	PIERCE	FOR
16AUG17	JWO	CDU	MODEL	ENFORCER
REV	DATE	BY	CH	