

BODY 107' ASL Tandem Axle Aluminum Body COMPT, DRIVER SIDE FRONT FH/FD RollUp w/o Chute COMPT, DRIVER SIDE REAR FH/FD RollUp and Lift-up Rearward COMPT, PASSENGER SIDE FRONT Full Height RollUp Forward COMPT, PASSENGER SIDE REAR Full Height RollUp and Liftup Rearward	WATER TANK 500 Gallon Notched Poly Water Tank Foam System Foam System Not Required Foam Cell Foam Cell Not Required
--	---

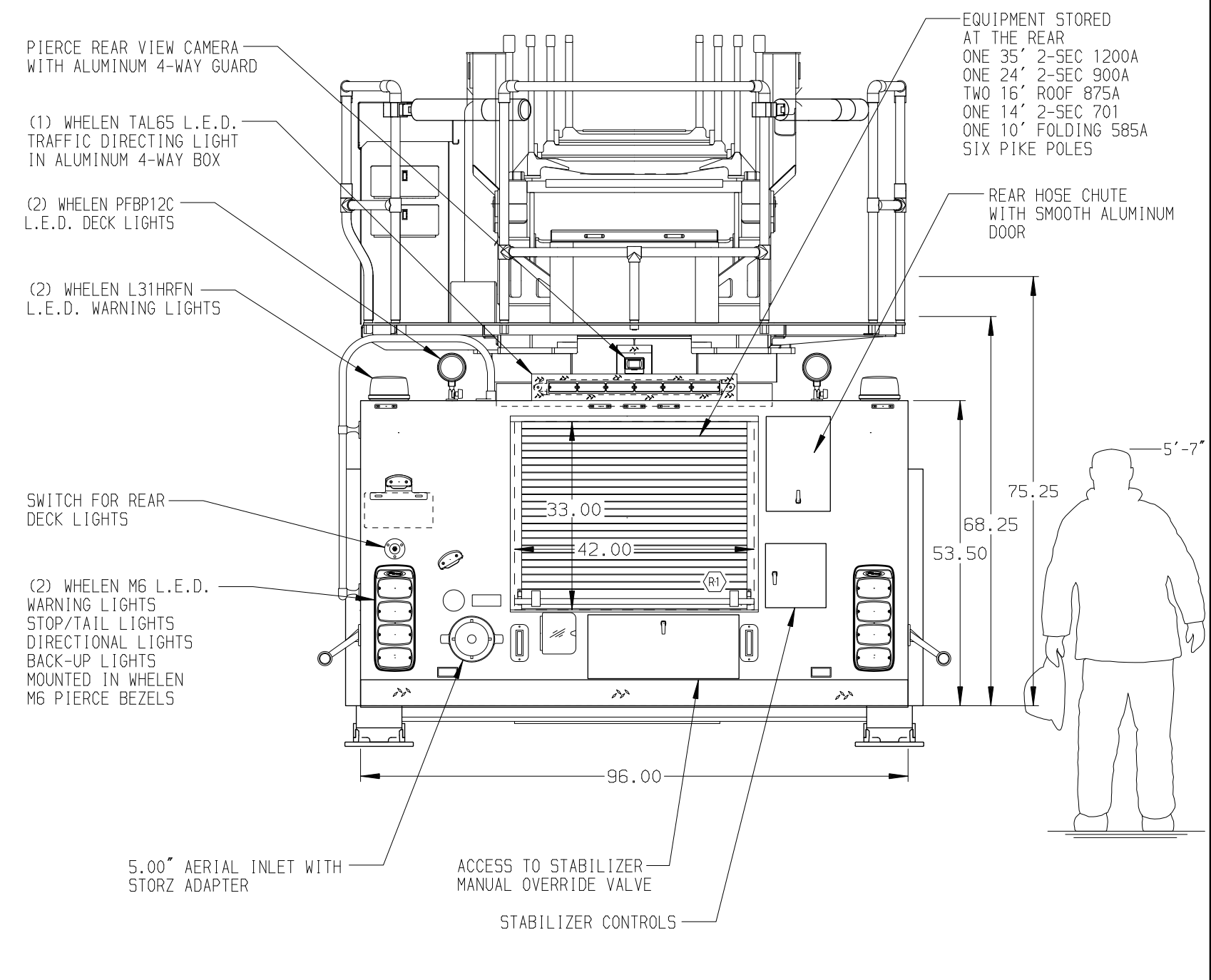

CHASSIS Velocity Chassis (Big Block) 600 HP Cummins X15 Engine	CAB 7010 Notched Velocity FR Cab 19" Extended Stainless Steel	AXLE, FRONT, CUSTOM 22,800 Lb TAK-4 Axle AXLE, REAR 44,000 Lb Meritor Axle	TRANSMISSION Allison 5th Gen, 4500 EV5 P	PUMPHOUSE 52" Control Zone Side Mount PUMP 2000 GPM Waterous CSU	CROSSLAYS, 1.50" (2) 1.50" Standard Capacity CROSSLAYS, 2.50" (1) 2.50" Standard Capacity	SPEEDLAYS Speedlays Not Required GENERATOR Generator Not Required	SAFETY Side Roll and Frontal Impact Protection
---	--	---	--	--	--	--	---

NOTE
 DIMENSIONS SHOWN ARE APPROXIMATE AND ARE SUBJECT TO MINOR DEVIATIONS AS MAY OCCUR OR BE NECESSARY IN CONSTRUCTION.
 MINOR DETAILS NOT SHOWN.

- 21.00" LIMITED RETRACTION
- ONE 1.50" OUTLET WITH 2.00" PIPING AND SHIVEL LOCATED IN CENTER BUMPER TRAY
- SHOULDER RECEPTACLE WITH KUSSMAUL SUPER AUTO-EJECT LOCATED ON DRIVER SIDE OF THE CAB
- AIR INLET WITH KUSSMAUL AIR-EJECT WITH COVER MOUNTED IN 4-WAY BOX IN THE DRIVER SIDE STEPPED
- AIR OUTLET WITH SHUT OFF VALVE LOCATED ON THE DRIVER SIDE PUMP PANEL
- BATTERY CHARGE/COMPRESSOR LOCATED IN THE CREW CAB SEAT RISER
- BATTERY CHARGE INDICATOR LOCATED ON THE DRIVER SIDE OF THE CAB
- SEVEN ADJUSTABLE SHELVES IN COMPARTMENTS PER SHOP ORDER
- ONE ADJUSTABLE TILTING SLIDE-OUT TRAY IN COMPARTMENT PER SHOP ORDER
- ONE ALUMINUM SWING-OUT TOOLBOARD WITH PAC TRAC IN COMPARTMENT PER SHOP ORDER

- 3.00" RAISED AERIAL PEDESTAL
- 1500 GPM HIGH FLOW WATERWAY

(MAXIMUM O.A.H. = 140.00" (11'-8.00"))

REV	DATE	BY	CH
11	JAN17	TKA	KBO

Pierce MANUFACTURING INC.

JOB NO. 32026

SCALE 1:24 DATE

TITLE 107' ASCENDANT AERIAL LADDER AND BODY ASSEMBLY

FOR FORT SMITH FIRE DEPARTMENT
FORT SMITH, ARKANSAS

CHECKED BY CRI DATE 03DEC17

DWG NO. 32026AD

SHEET SIZE D SHEET NO. 1 OF 1