

PASSENGER'S SIDE COMPARTMENTS CONTAIN THE FOLLOWING:

COMPARTMENT P1 CONTAINS:

COMPARTMENT P2 CONTAINS:

COMPARTMENT P3 CONTAINS:

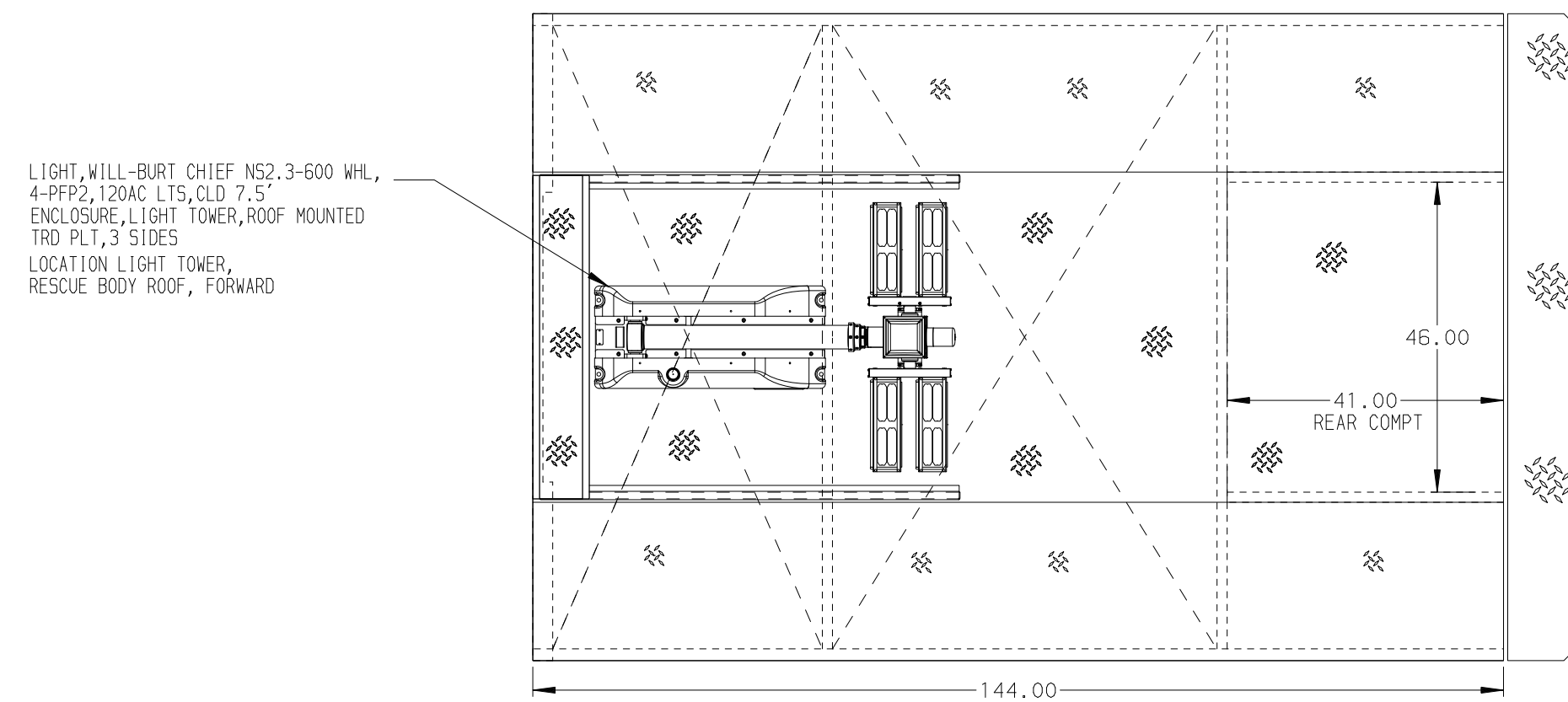
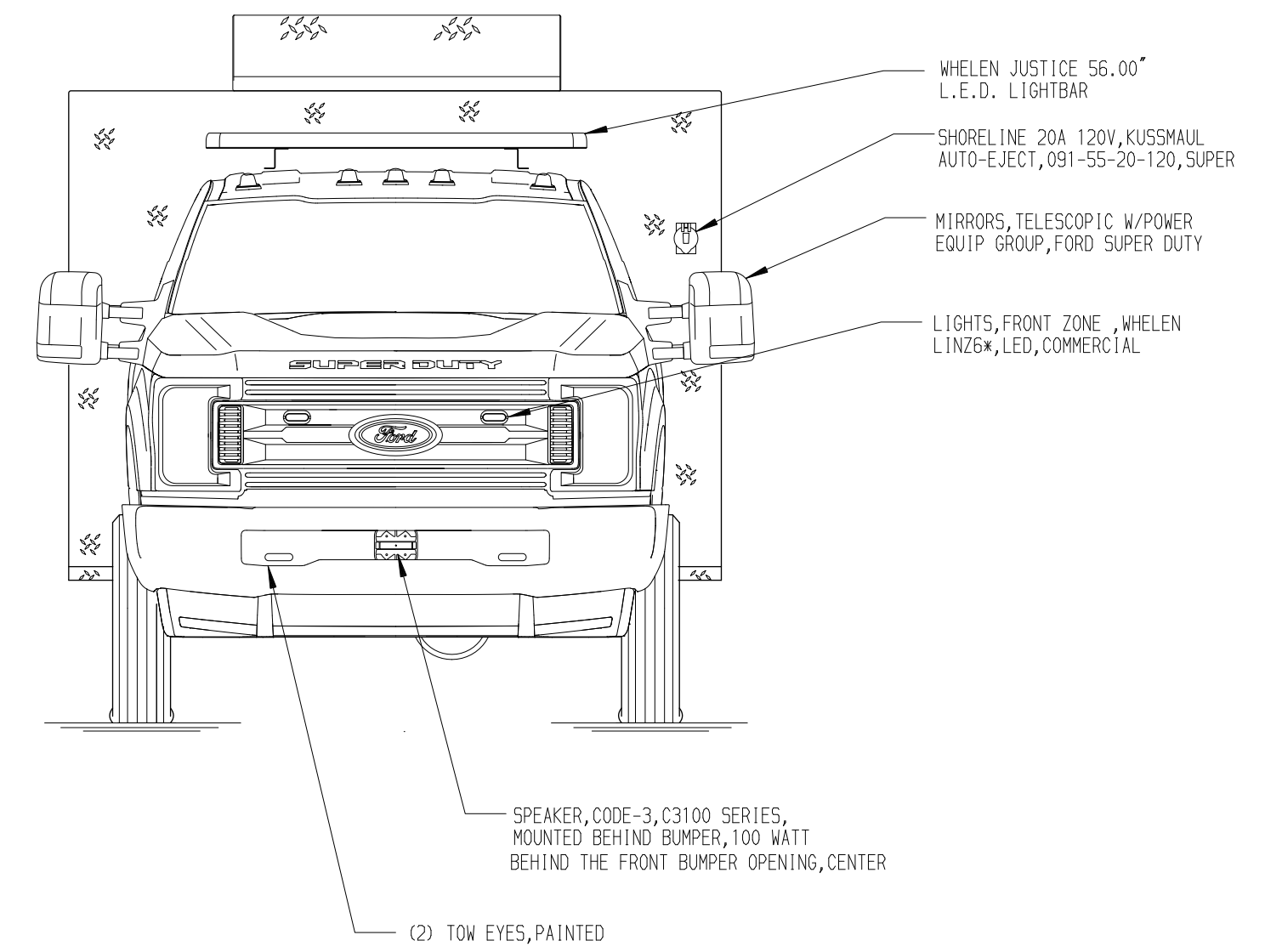
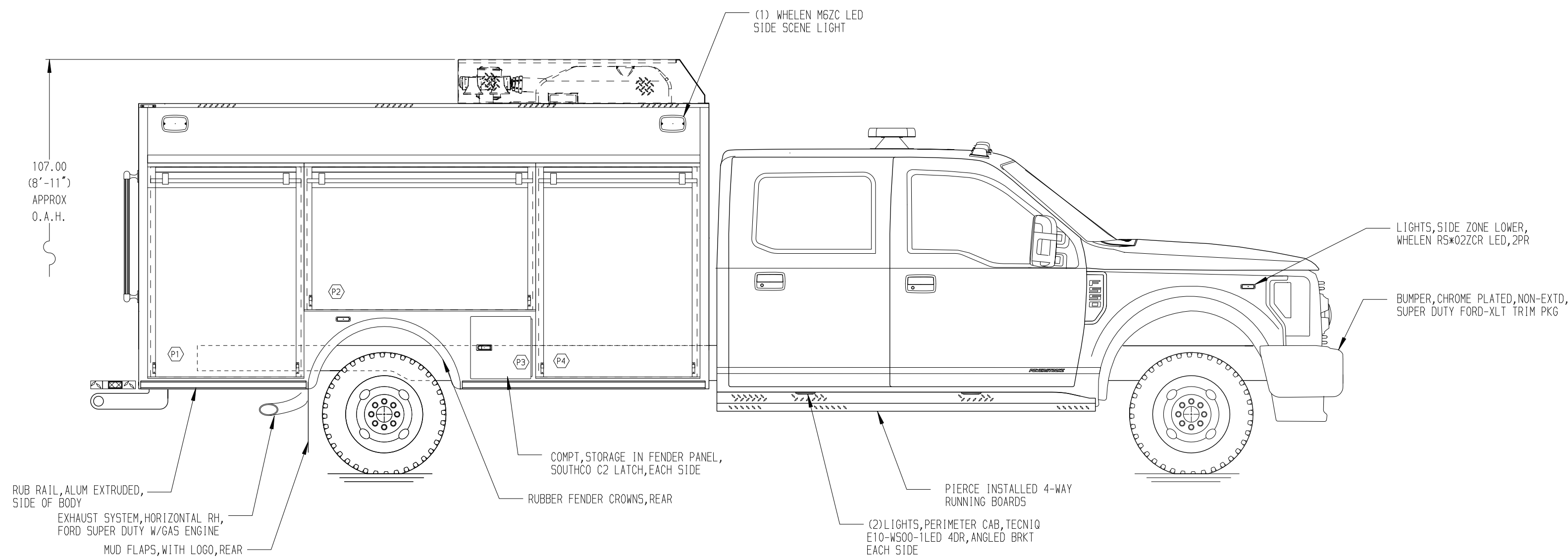

REAR COMPARTMENT R1 CONTAINS THE FOLLOWING:

COMPARTMENT R1 CONTAINS:

- (1) TRAY SLIDE OUT, STD DEPTH, FLOOR MOUNTED, 500LB CAPACITY

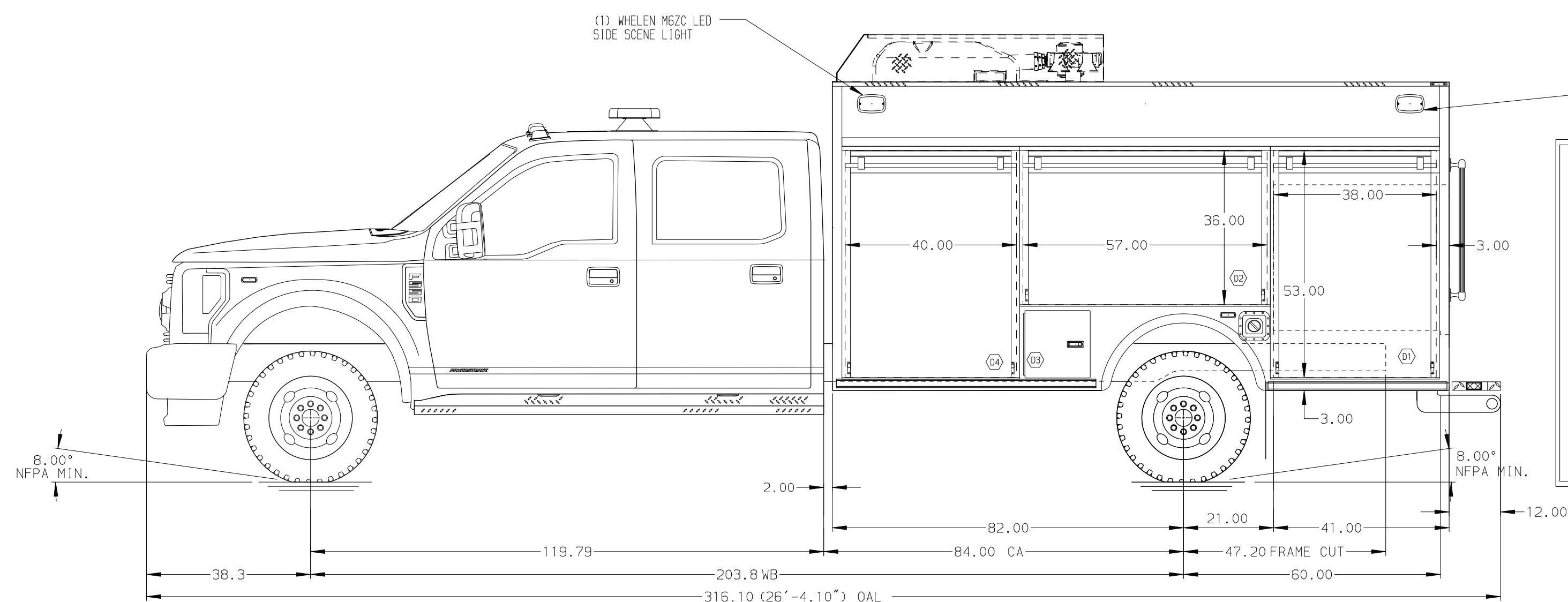

DRIVER'S SIDE COMPARTMENTS CONTAIN THE FOLLOWING:

COMPARTMENT D1 CONTAINS:

COMPARTMENT D2 CONTAINS:

COMPARTMENT D3 CONTAINS:

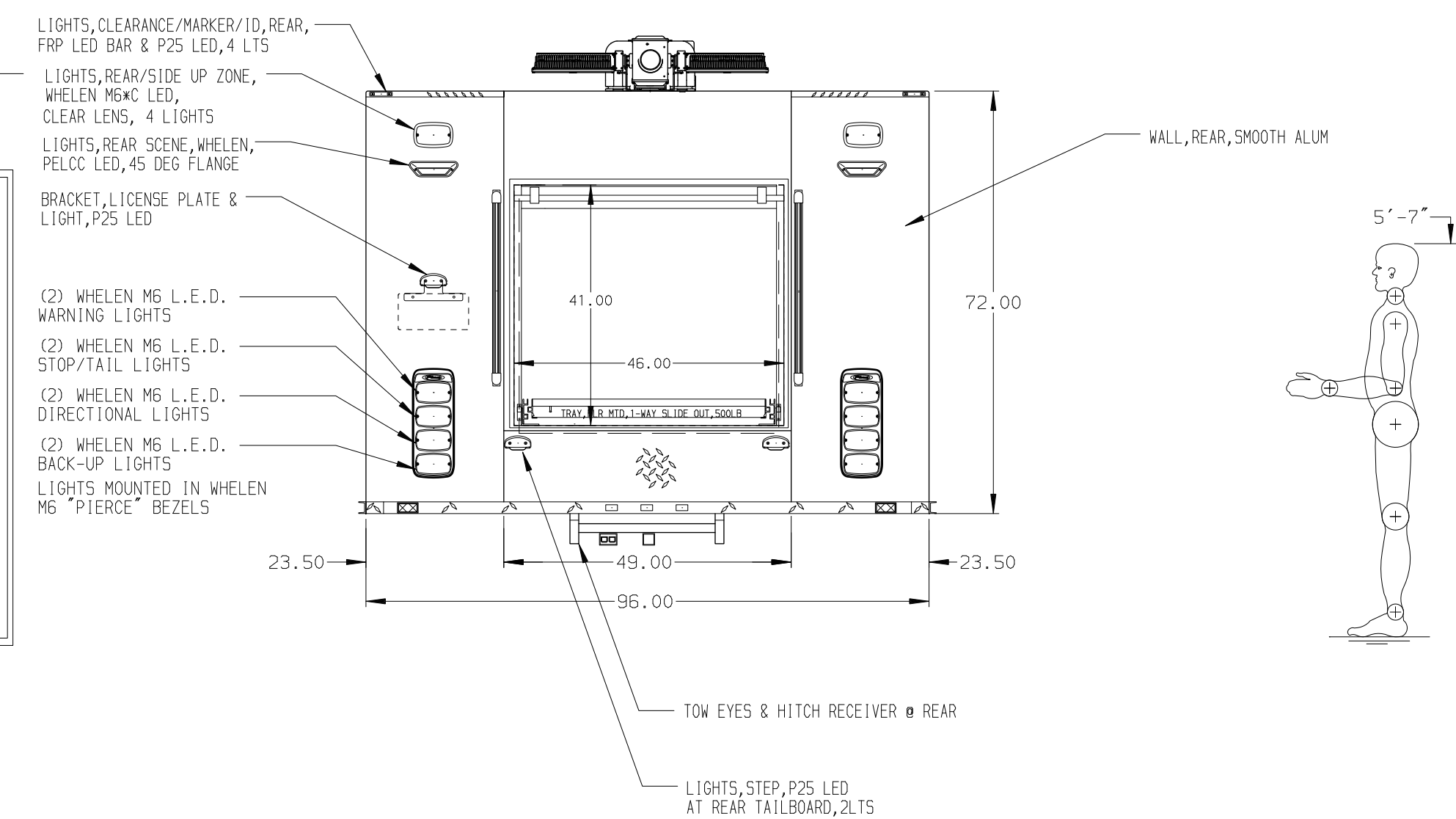

ALUMINUM BODY

NOTE
DIMENSIONS SHOWN ARE APPROXIMATE AND ARE SUBJECT TO MINOR DEVIATIONS AS MAY OCCUR OR BE NECESSARY IN CONSTRUCTION.
MINOR DETAILS NOT SHOWN.

Pierce MANUFACTURING INC.
BRADENTON, FLORIDA

JOB NO.	32127
SCALE	1:24
DATE	10JAN18
DRAWN BY	JAF
DATE	12JAN18
CHK'D BY	RWI
SHEET NO.	1 OF 1
SHEET SIZE	D

REV.	DATE	BY	CHK'D	CHASSIS DATA
03APR18	JAF	NAS		FORD
02FEB18	RWI	JAF		MODEL F-550 4X4

TITLE 12' RESCUE, NON-WALK-IN

FOR AKRON FIRE DEPARTMENT AKRON, OHIO

DRWG. NO. 32127AD