

- HOSEBED CAPACITIES
- ① 500' OF 3.00" D.J. POLY HOSE
 - ② 1000' OF 5.00" D.J. POLY HOSE
 - ③ 500' OF 3.00" D.J. POLY HOSE

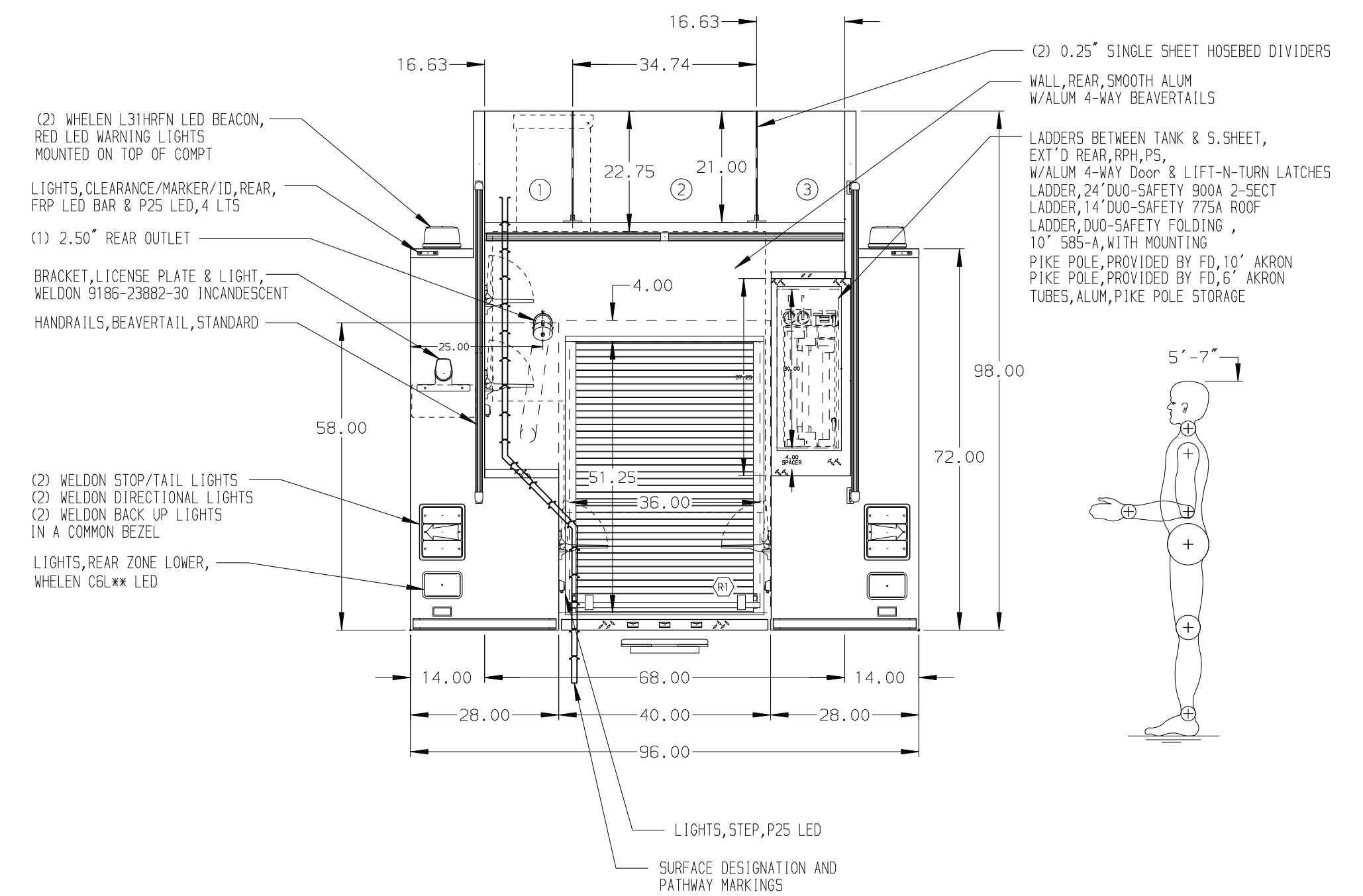
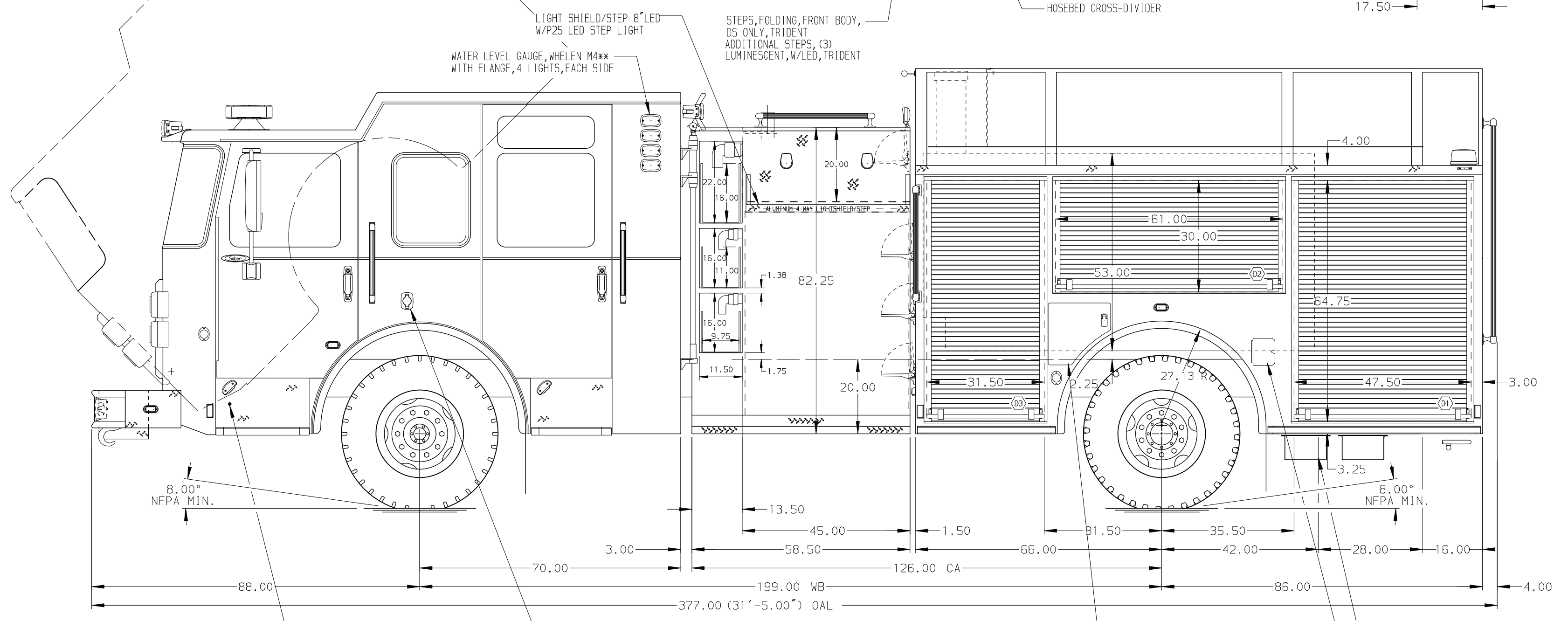

ALUMINUM BODY

NOTE
DIMENSIONS SHOWN ARE APPROXIMATE AND ARE SUBJECT TO MINOR DEVIATIONS AS MAY OCCUR OR BE NECESSARY IN CONSTRUCTION. MINOR DETAILS NOT SHOWN.

		Pierce MANUFACTURING INC.		JOB NO.	32311
				SCALE	1:24
				DATE	
				DRAWN BY	JAF
				CHECKED BY	AJA
				SHEET SIZE	D
				SHEET NO.	1 OF 1
CHASSIS DATA	TITLE	1250-D-1000, 1000 POLY 152" BODY DS&PS FULL HGT, FDLER 45" SIDE MNT, (2) 1.50" & (1) 2.50" SPEEDAYS W/POLY TRAYS			
MAKE	FOR	PIERCE PETAL FIRE DEPARTMENT PETAL MISSISSIPPI			
MODEL	DWG NO.	32311AD			
SABER FR	REV	DATE	BY	CH	
	11MAY18		JAF	AJA	