

118.00
(9'-10")
APPROX
O.A.H.

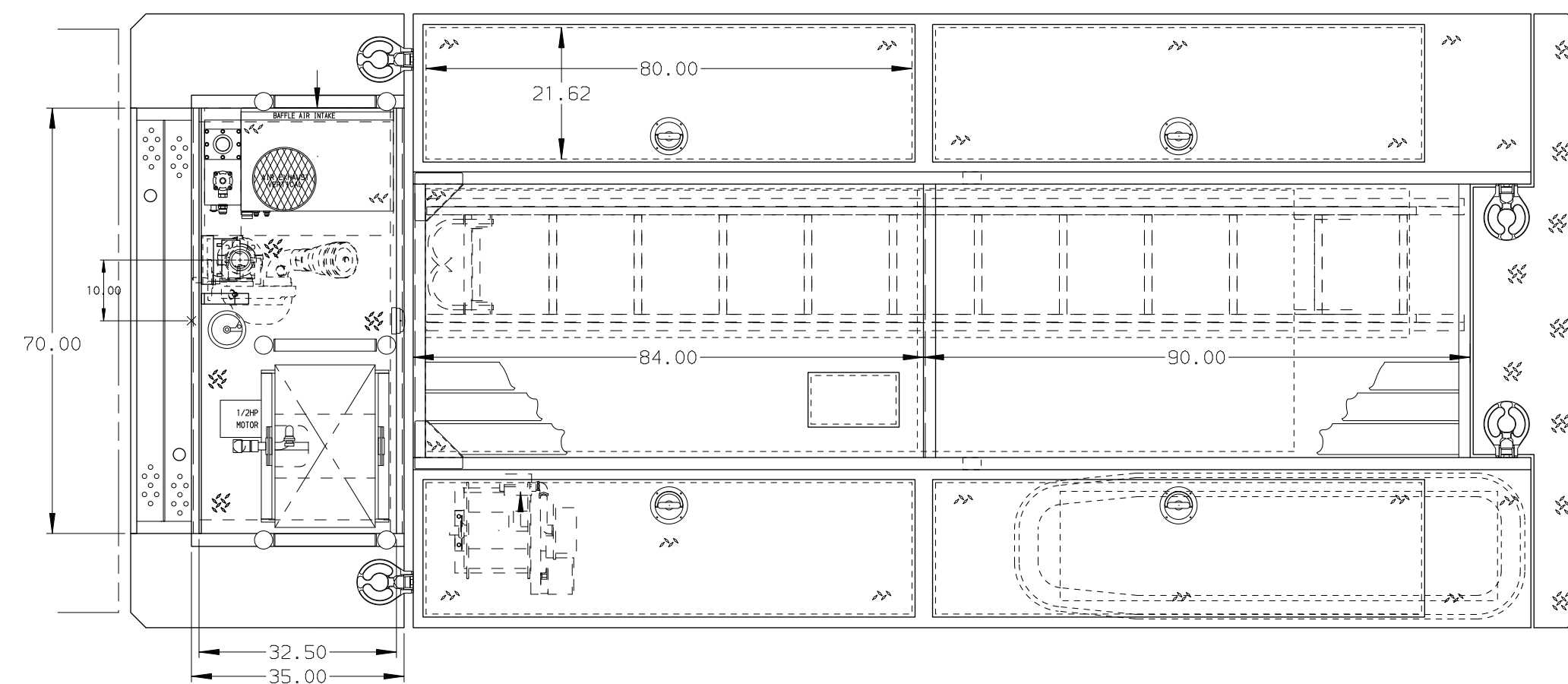

- HOSEBED CAPACITIES
- ① 375' OF 1.75" D.J. HOSE
 - ② 200' OF 2.50" D.J. HOSE
 - ③ 350' OF 2.50" D.J. HOSE
 - ④ 1000' OF 5.00" D.J. HOSE

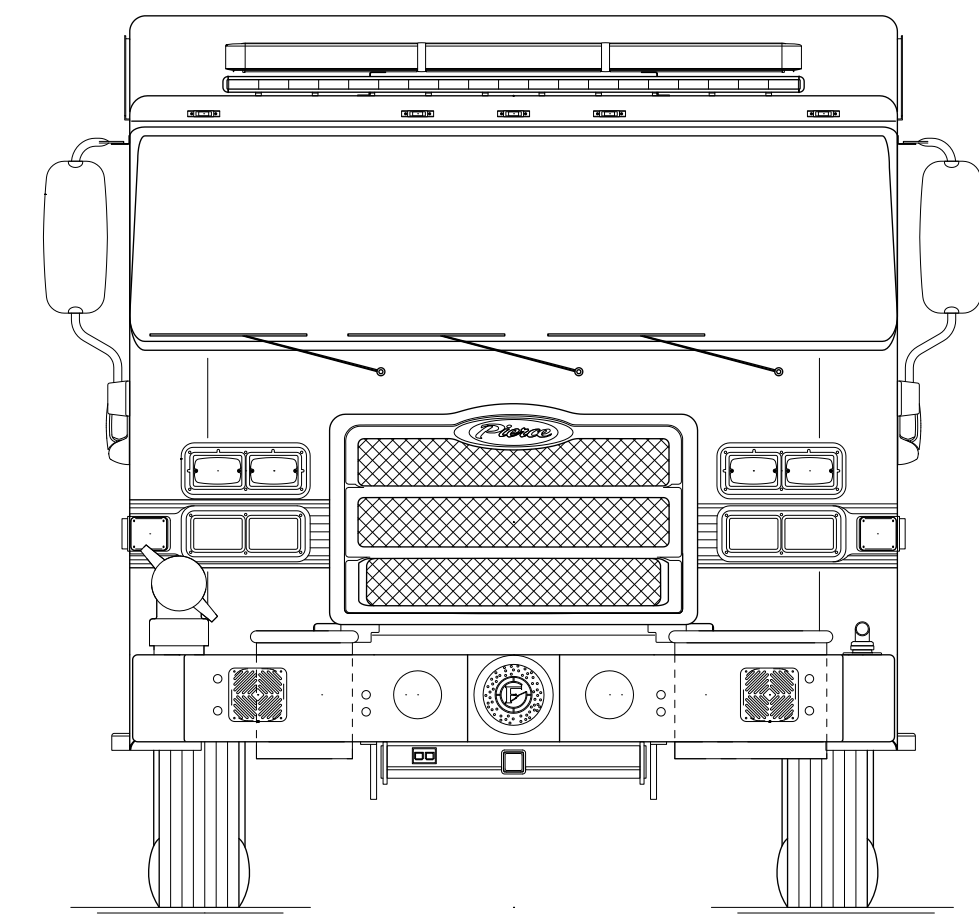
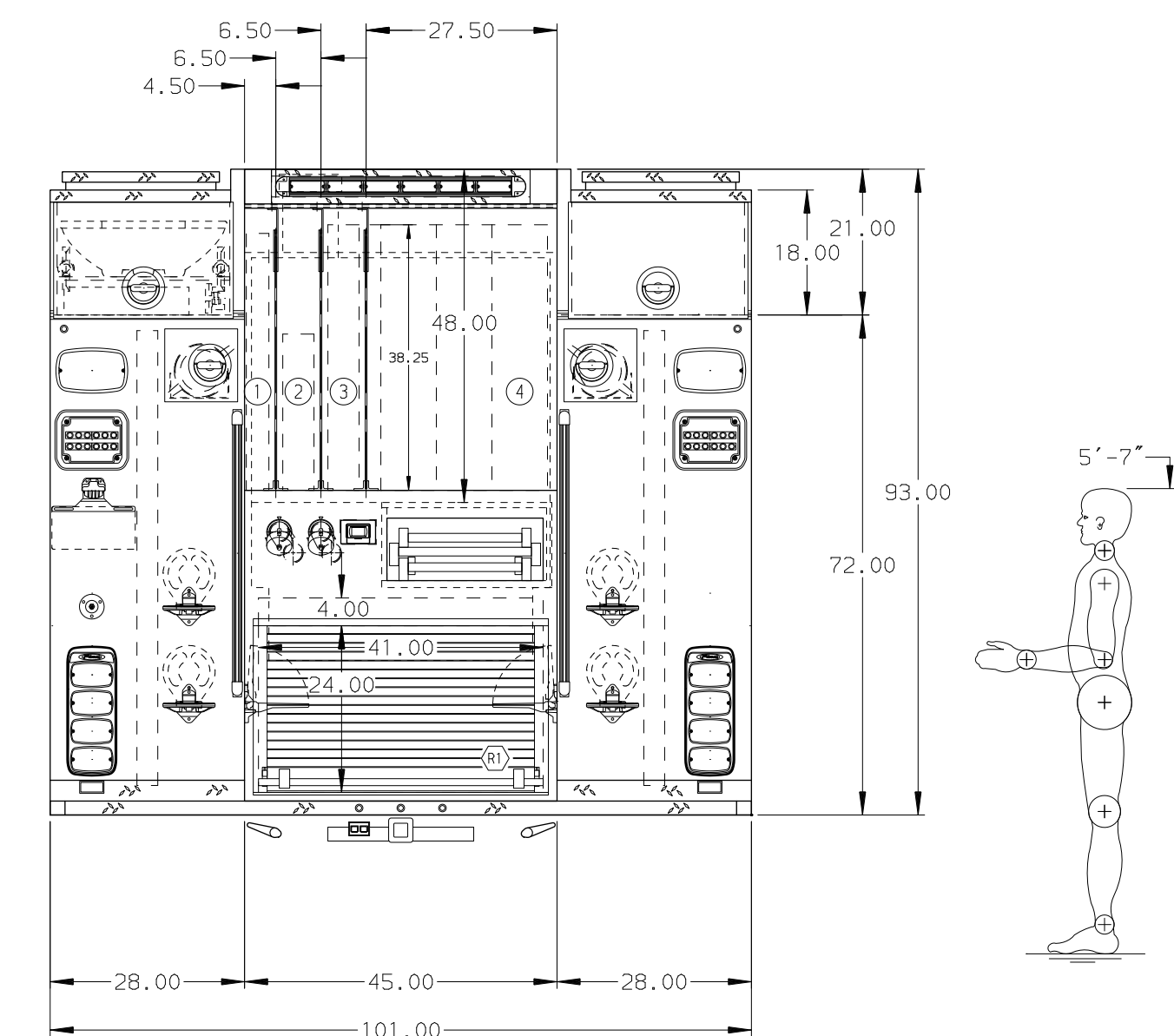
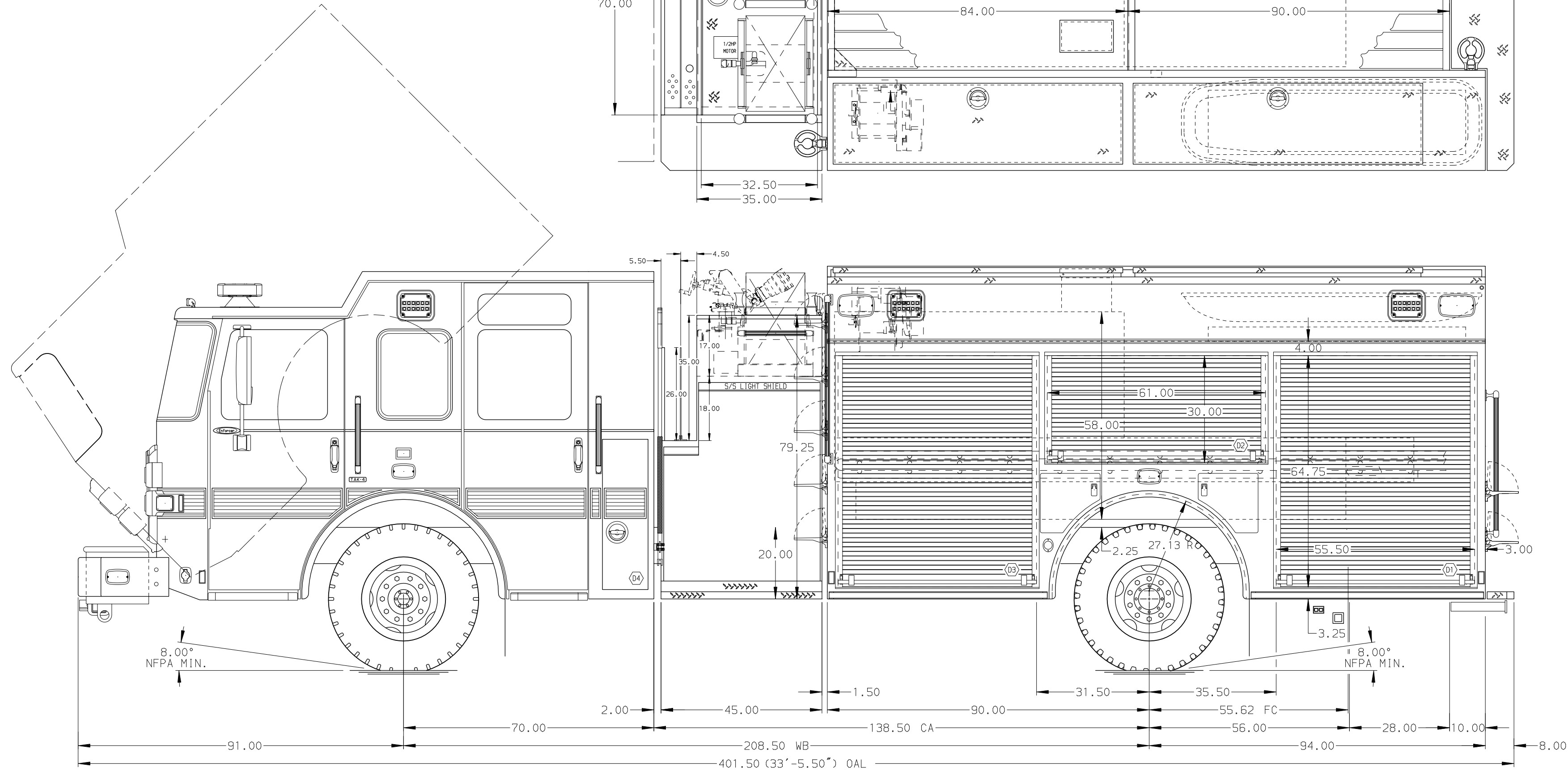

ALUMINUM BODY MAXIMUM O.A.L. 384" MAXIMUM O.A.H. 118" SIDE ROLL AND FRONTAL IMPACT PROTECTION

NOTE
DIMENSIONS SHOWN ARE APPROXIMATE
AND ARE SUBJECT TO MINOR DEVIATIONS
AS MAY OCCUR OR BE NECESSARY IN
CONSTRUCTION.
MINOR DETAILS NOT SHOWN.

| CUSTOMER APPROVAL | | | | |
|-------------------|------|----|----|----------|
| APPROVED BY: | | | | |
| DATE: | | | | |
| REV | DATE | BY | CH | ENFORCER |



TITLE 1500-D-750 GAL POLY, 184" HDRP BODY, SIDE CONTROL LADDER TUNNEL, DELUGE, GENERATOR, BOOSTER REEL
FOR STEELE CREEK FIRE DEPARTMENT
STEELE CREEK, NORTH CAROLINA
DWG NO. 32491AD

| | |
|------------|---------|
| JOB NO. | 32491 |
| SCALE | 1:24 |
| DATE | |
| DRAWN BY | - |
| CHECKED BY | CDU |
| SHEET NO. | 04MAY18 |
| SHEET SIZE | D |
| SHEET NO. | 1 OF 1 |

