

(1) CODE 3 468CBZ L.E.D. STABILIZER WARNING LIGHT EACH SIDE
 (2) SPECIAL DOUBLE AIR BOTTLE COMPARTMENTS 14.00 W x 7.50 H x 26.00 D

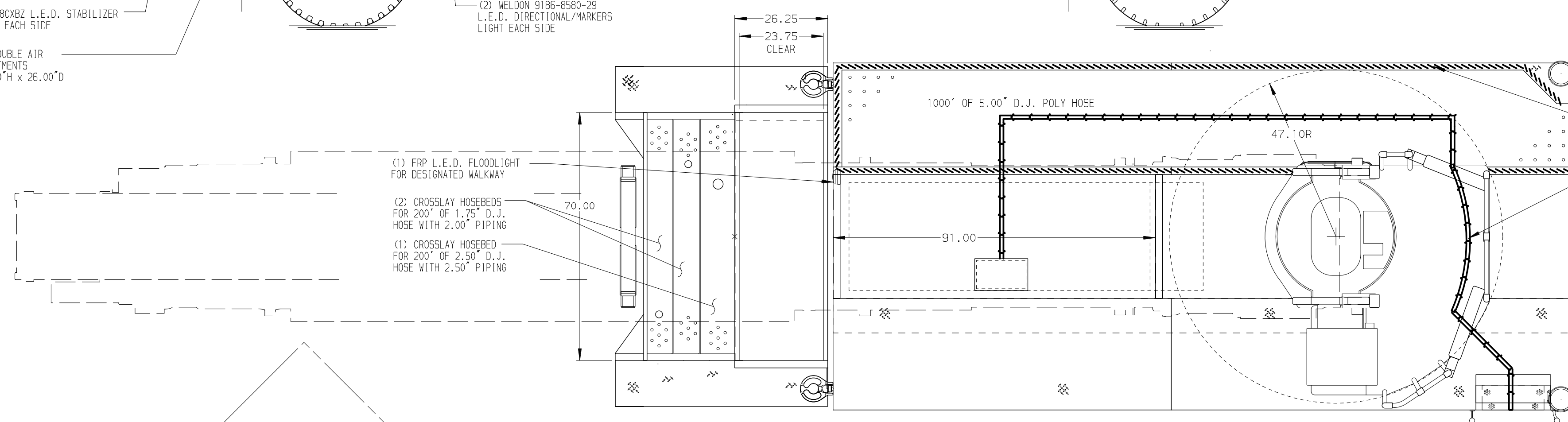

(1) FRP L.E.D. FLOODLIGHT FOR DESIGNATED WALKWAY
 (2) CROSSLAY HOSEBEDS FOR 200' OF 1.75\"/>

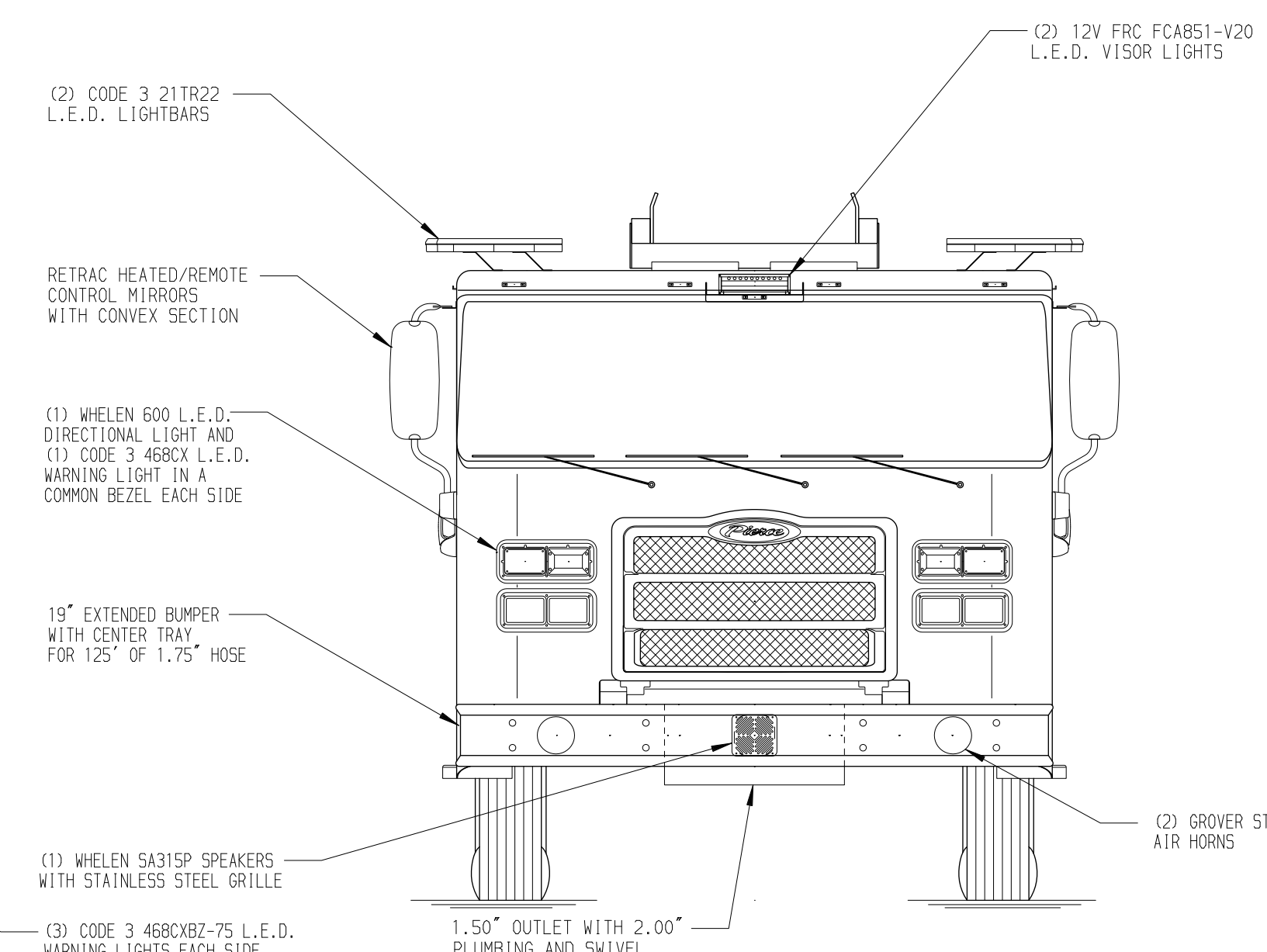

(2) CODE 3 21TR22 L.E.D. LIGHTBARS
 (2) 12V FRC FC4851-V20 L.E.D. VISOR LIGHTS
 RETRAC HEATED/REMOTE CONTROL MIRRORS WITH CONVEX SECTION
 (1) WHELEN 600 L.E.D. DIRECTIONAL LIGHT AND (1) CODE 3 468CB L.E.D. WARNING LIGHT IN A COMMON BEZEL EACH SIDE
 19\"/>

(1) WHELEN 5A315P SPEAKERS WITH STAINLESS STEEL GRILLE
 (3) CODE 3 468CBZ-75 L.E.D. WARNING LIGHTS EACH SIDE

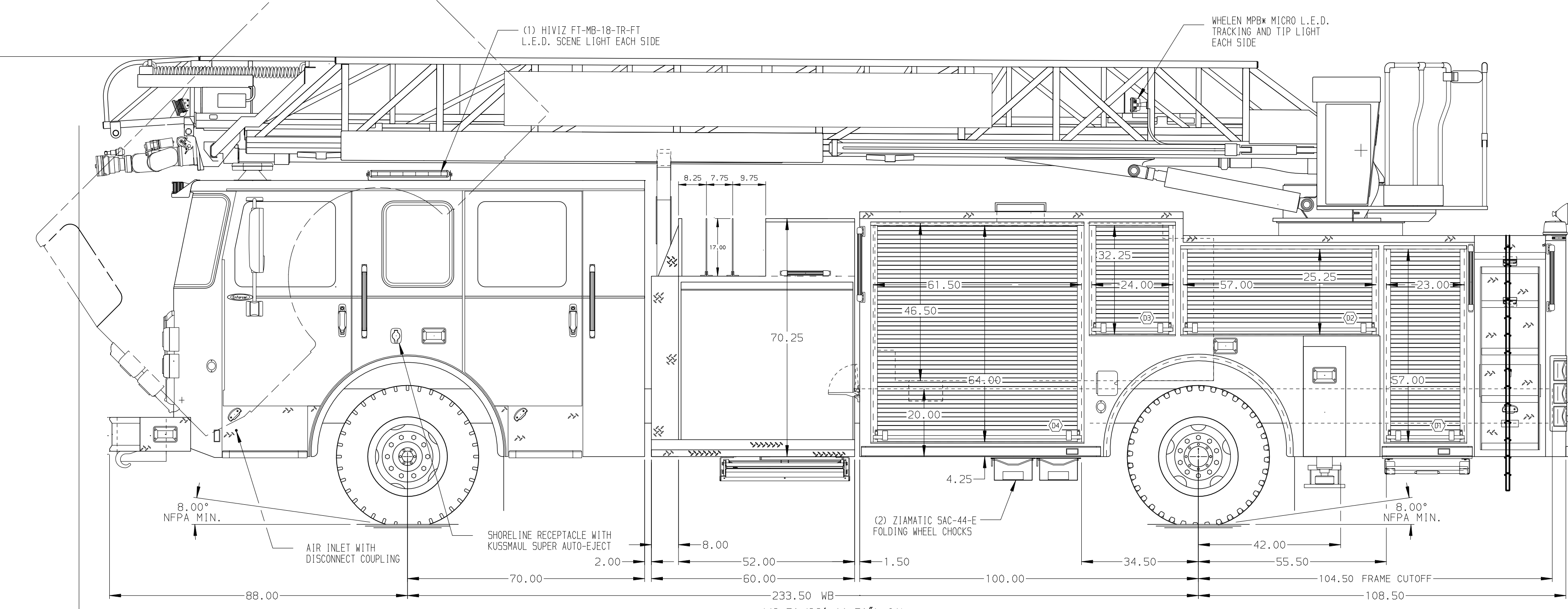

139.00 (11'-7\"/>

8.00\"/>

AIR INLET WITH DISCONNECT COUPLING

SHORELINE RECEPTACLE WITH KUSHMAUL SUPER AUTO-EJECT

(2) ZIAMATIC SAC-44-E FOLDING WHEEL CHOCKS

8.00\"/>

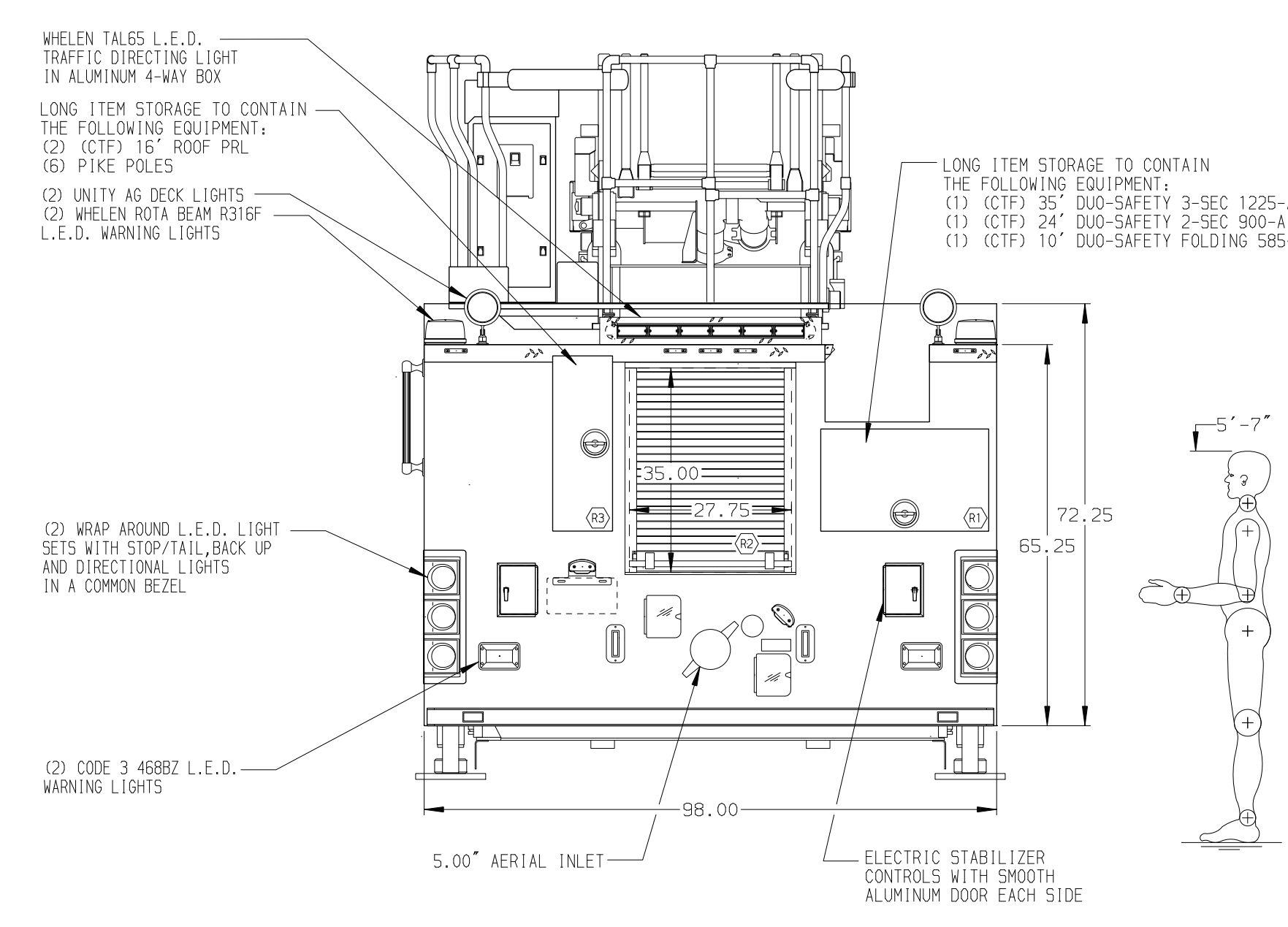

WHELEN TAL65 L.E.D. TRAFFIC DIRECTING LIGHT IN ALUMINUM 4-WAY BOX
 LONG ITEM STORAGE TO CONTAIN THE FOLLOWING EQUIPMENT:
 (2) (CTF) 16\"/>

(2) WRAP AROUND L.E.D. LIGHT SETS WITH STOP/TAIL, BACK UP AND DIRECTIONAL LIGHTS IN A COMMON BEZEL

(2) CODE 3 468BZ L.E.D. WARNING LIGHTS

LONG ITEM STORAGE TO CONTAIN THE FOLLOWING EQUIPMENT:
 (1) (CTF) 35\"/>

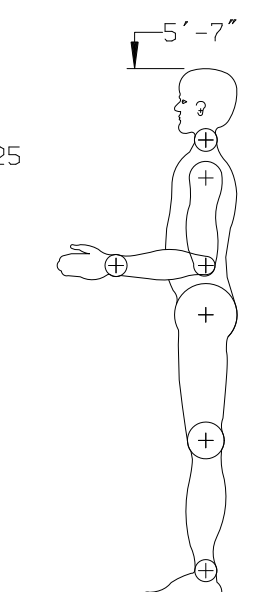

ALUMINUM BODY

NOTE
 DIMENSIONS SHOWN ARE APPROXIMATE AND ARE SUBJECT TO MINOR DEVIATIONS AS MAY OCCUR OR BE NECESSARY IN CONSTRUCTION. MINOR DETAILS NOT SHOWN.

- BATTERY CHARGER LOCATED IN COMPARTMENT D4
- BATTERY CHARGE INDICATOR LOCATED ON DRIVER'S SEAT RISER
- ONE ADJUSTABLE FULL WIDTH/FULL DEPTH SHELF IN COMPARTMENTS TBD
- ONE FLOOR MOUNTED SLIDE-OUT TRAY IN COMPARTMENTS TBD
- 1500 GPM HIGH FLOW WATERWAY
- 1.50\"/>

| | | |
|--------------|---------|---------------------------------------------|
| CHASSIS DATA | TITLE | 75' HAL TCO AERIAL LADDER AND BODY ASSEMBLY |
| PIERCE | MAKE | 500 GALLON WATER TANK |
| PIERCE | FOR | NAVARRE BEACH FIRE DEPARTMENT |
| PIERCE | MODEL | NAVARRE, FLORIDA |
| ENFORCER | DWG NO. | 32557AD |

| | | | |
|----------|------|------------|--------|
| | | JOB NO. | 32557 |
| SCALE | 1:24 | DATE | |
| DRAWN BY | MWA | CHECKED BY | CRI |
| | | SHEET SIZE | D |
| | | SHEET NO. | 1 OF 1 |