

| BODY | WATER TANK |
|-----------------------------|---------------------------------------|
| 75' HAL Aluminum Body | 500 Gallon Poly Water Tank |
| COMPT, LEFT SIDE FRONT | Foam System |
| Full Height RollUp Forward | Plumbing for Future Husky Foam System |
| COMPT, LEFT SIDE REAR | Foam Cell |
| Full Height RollUp Rearward | Foam Cell Not Required |
| COMPT, RIGHT SIDE FRONT | |
| Full Height RollUp Forward | |
| COMPT, RIGHT SIDE REAR | |
| Full Height RollUp Rearward | |

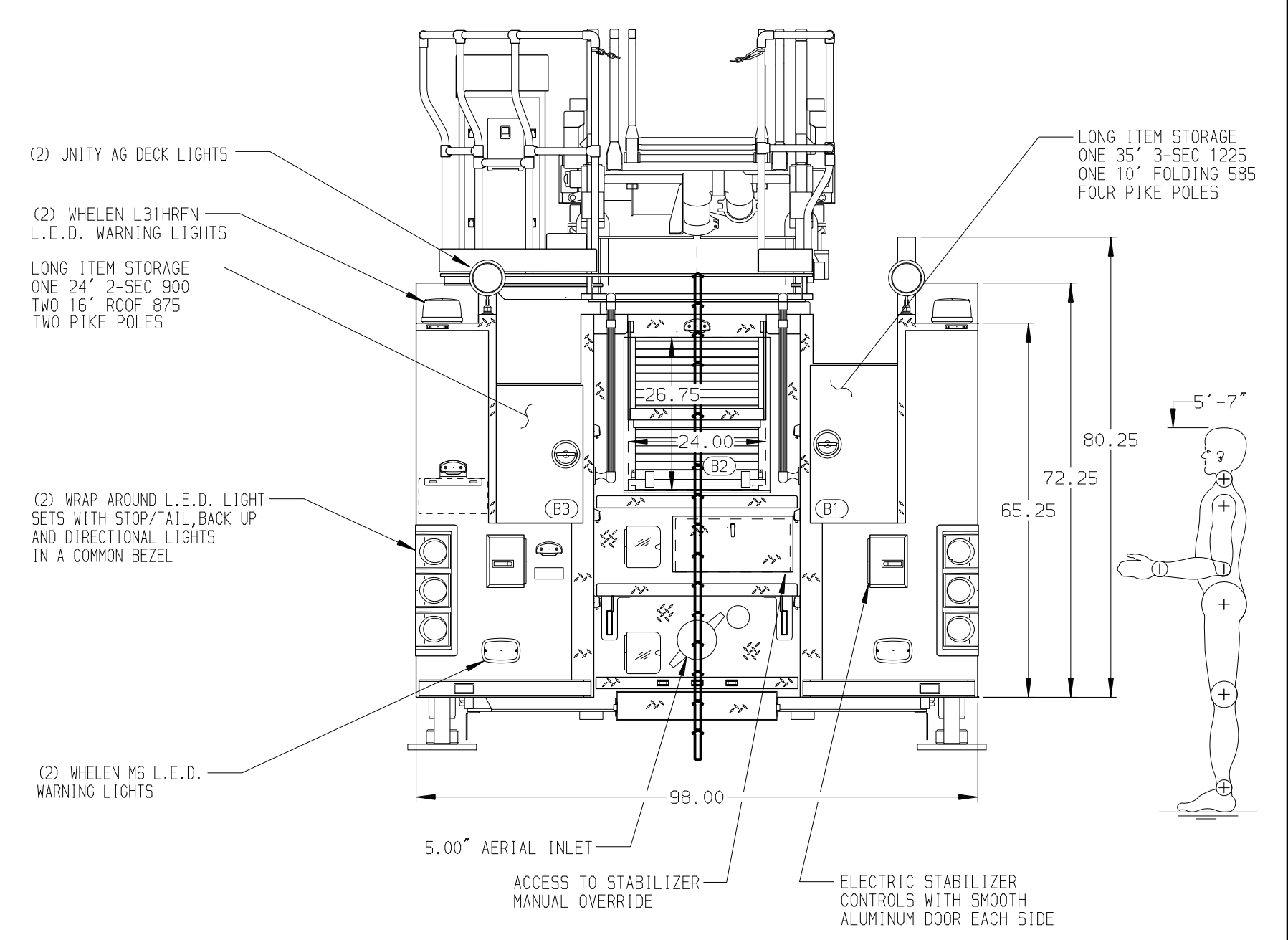

| CHASSIS | CAB | AXLE, FRONT, CUSTOM | TRANSMISSION | PUMPHOUSE | CROSSLAYS, 1.50" | SPEEDLAYS | CUSTOMER APPROVAL | | JOB NO. |
|--|--|--|-----------------------------|---|---|--|-----------------------------------|------------|---------|
| Enforcer Chassis ENGINE 400 HP Cummins L9 Engine | 7000 Enforcer Cab BUMPER 19" Extended Stainless Steel | 19,500 Lb TAK-4 Axle AXLE, REAR 33,500 Lb Meritor Axle | Allison 5th Gen, 3000 EV5 P | 45" Control Zone Side Mount PUMP 1500 GPM Waterous CSU | (2) 1.50" Standard Capacity CROSSLAYS, 2.50" 2.50" Crosslay Not Required | Speedlays Not Required GENERATOR Generator Not Required | APPROVED BY: _____ DATE: _____ | | 33583 |
| NOTE DIMENSIONS SHOWN ARE APPROXIMATE AND ARE SUBJECT TO MINOR DEVIATIONS AS MAY OCCUR OR BE NECESSARY IN CONSTRUCTION. MINOR DETAILS NOT SHOWN. | | <ol style="list-style-type: none"> ONE 1.50" OUTLET WITH 2.00" PIPING AND SWIVEL LOCATED IN CENTER BUMPER TRAY SHORELINE RECEPTACLE WITH KUSSMALL SUPER AUTO-EJECT LOCATED ON DRIVER SIDE OF THE CAB AIR INLET WITH DISCONNECT COUPLING IN THE DRIVER SIDE STEPWELL BATTERY CHARGER LOCATED IN COMPARTMENT PER SHOP ORDER BATTERY CHARGE INDICATOR LOCATED PER SHOP ORDER FOUR ADJUSTABLE SHELVES IN COMPARTMENTS PER SHOP ORDER 7.00" AERIAL LIMITED RETRACTION 1.50" RAISED AERIAL PEDESTAL 1500 GPM HIGH FLOW WATERWAY TRIDENT FOLDING STEPS ON AERIAL DEVICE | | | | | | | |
| Pierce | | MANUFACTURING INC. | | TITLE | | 75 AERIAL LADDER & BODY ASSEMBLY | | DRAWN BY | |
| Pierce | | FOR | | PIERCE | | PIERCE FIELD UNIT APPLETON, WI | | CHECKED BY | |
| REV | | DATE | | BY | | CH | | SHEET SIZE | |
| | | | | | | | | D | |
| | | | | | | | | SHEET NO. | |
| | | | | | | | | 1 OF 1 | |