

HOSEBED CAPACITIES

① 1000' OF 5.00" D.J. HOSE

② 450' OF 3.00" D.J. HOSE

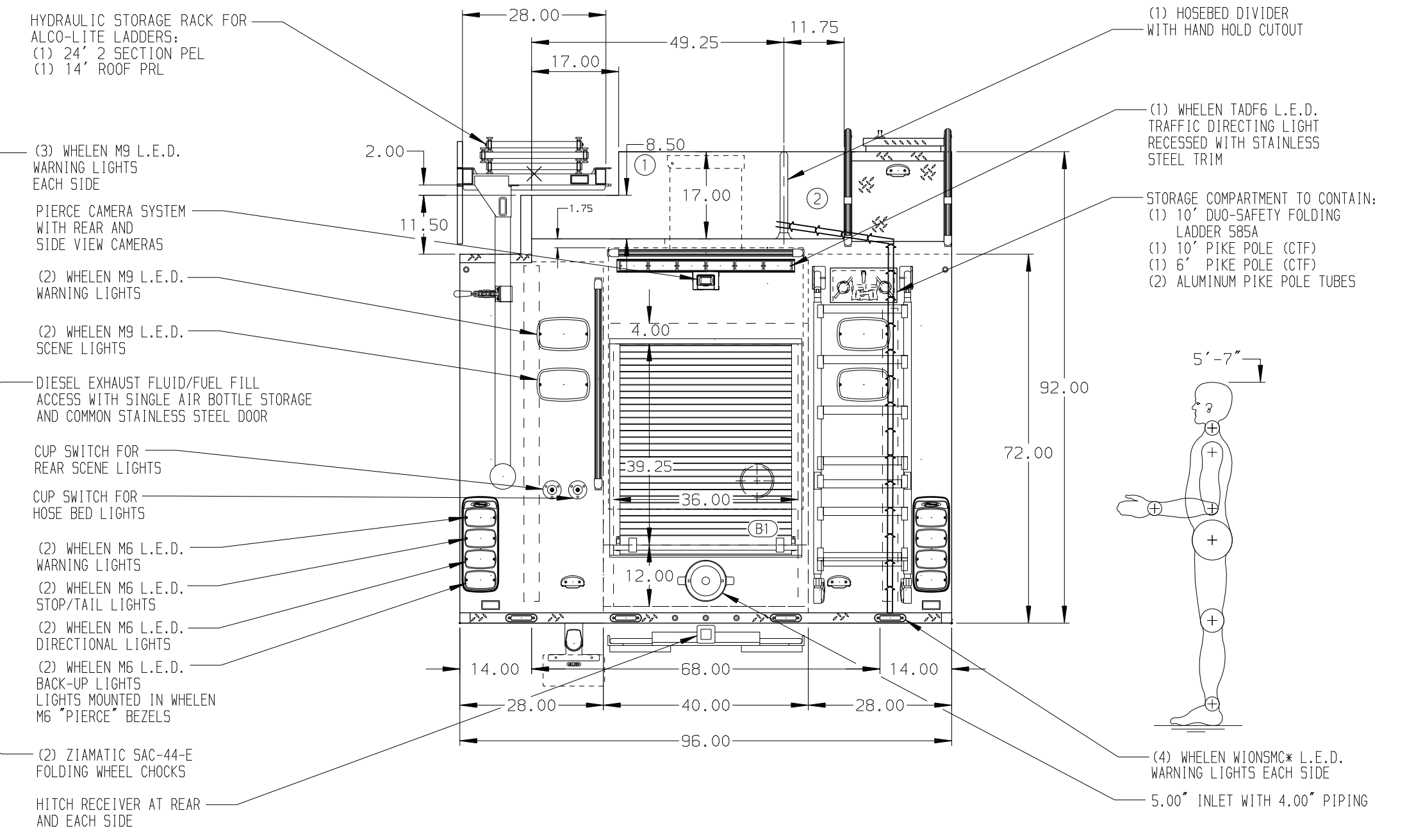
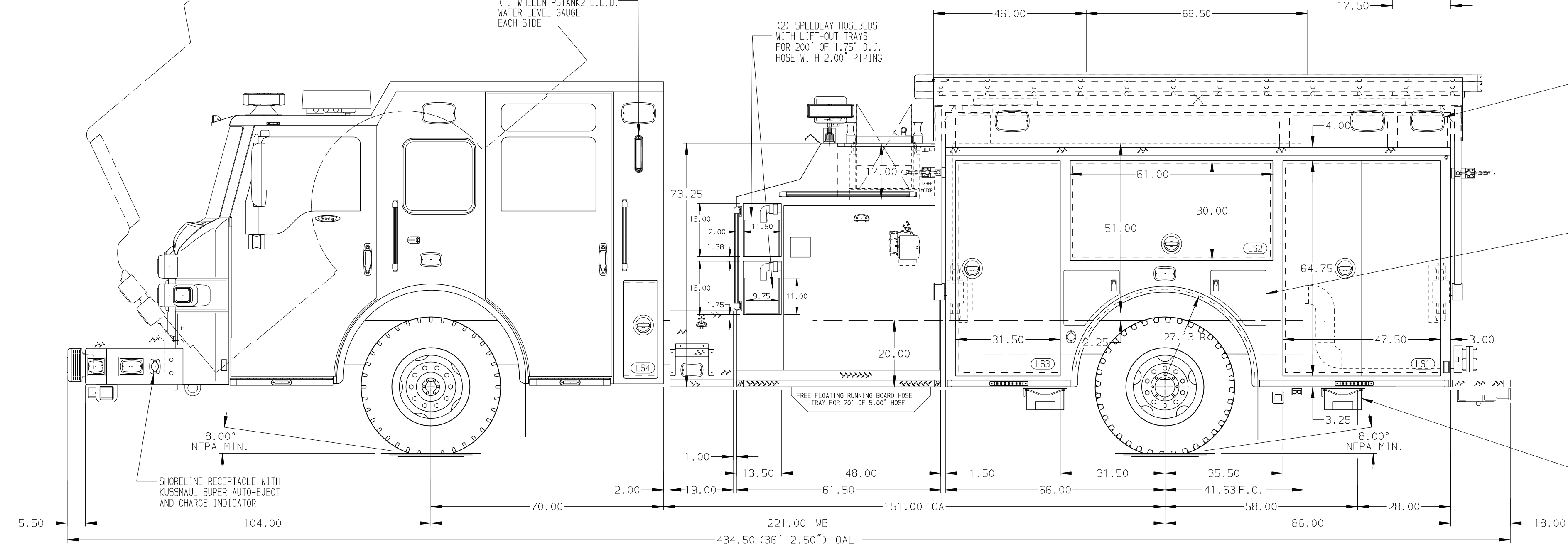

ALUMINUM BODY

NOTE
DIMENSIONS SHOWN ARE APPROXIMATE AND ARE SUBJECT TO MINOR DEVIATIONS AS MAY OCCUR OR BE NECESSARY IN CONSTRUCTION. MINOR DETAILS NOT SHOWN.

- AIR OUTLET WITH SHUT OFF VALVE ON DS PUMP PANEL
- DUAL L.E.D. LIGHT STRIPS LOCATED IN HOSE BED
- PULL STRAP ON DOOR IN COMPARTMENT LS2,RS3
- REVERSED HINGED DOOR ON COMPARTMENTS LS3,RS3
- ONE FULL WIDTH/DEPTH ADJUSTABLE SHELF IN COMPARTMENT LS1,LS3,RS1,B1, TWO IN RS3
- ONE ADJUSTABLE TILTING SLIDE-OUT TRAY IN COMPARTMENT 2LS2,LS3,RS2,RS3
- SLIDE-OUT TOOL BOARD WITH PEGBOARD PATTERN IN COMPARTMENT LS1
- PARTITION BETWEEN COMPARTMENTS LS1/B1 AND RS1/B1
- ONE VERTICAL PARTITION IN COMPARTMENT LS1
- AIR INLET WITH DISCONNECT COUPLING IN DS STEP WELL
- BATTERY CHARGER LOCATED IN COMPARTMENT LS3
- BATTERY CHARGE INDICATOR LOCATED ON DRIVER'S SIDE SEAT BRACKET

		JOB NO.	34133
		SCALE	DATE
Pierce MANUFACTURING INC.		TITLE	1500-D-750P, 152", FULL HEIGHT, FULL DEPTH D.S. & P.S.
		FOR	(2) SPEED-LAYS, DELUGE, BOOSTER REEL
		CHECKED BY	BEREA FIRE DEPARTMENT
		DRAWN BY	BEREA, SOUTH CAROLINA
		SHEET SIZE	15JUL19
		NO.	17JUL19
		REV	SHEET NO.
		DATE	1 OF 1
		BY	
		CH	
		VELOCITY	
		DWG NO.	34133AD