

- HOSEBED CAPACITIES**
- ① 1000' OF 4.00" RUBBER HOSE
 - ② 500' OF 2.50" D.J. POLY HOSE
 - ③ 500' OF 1.75" D.J. POLY HOSE

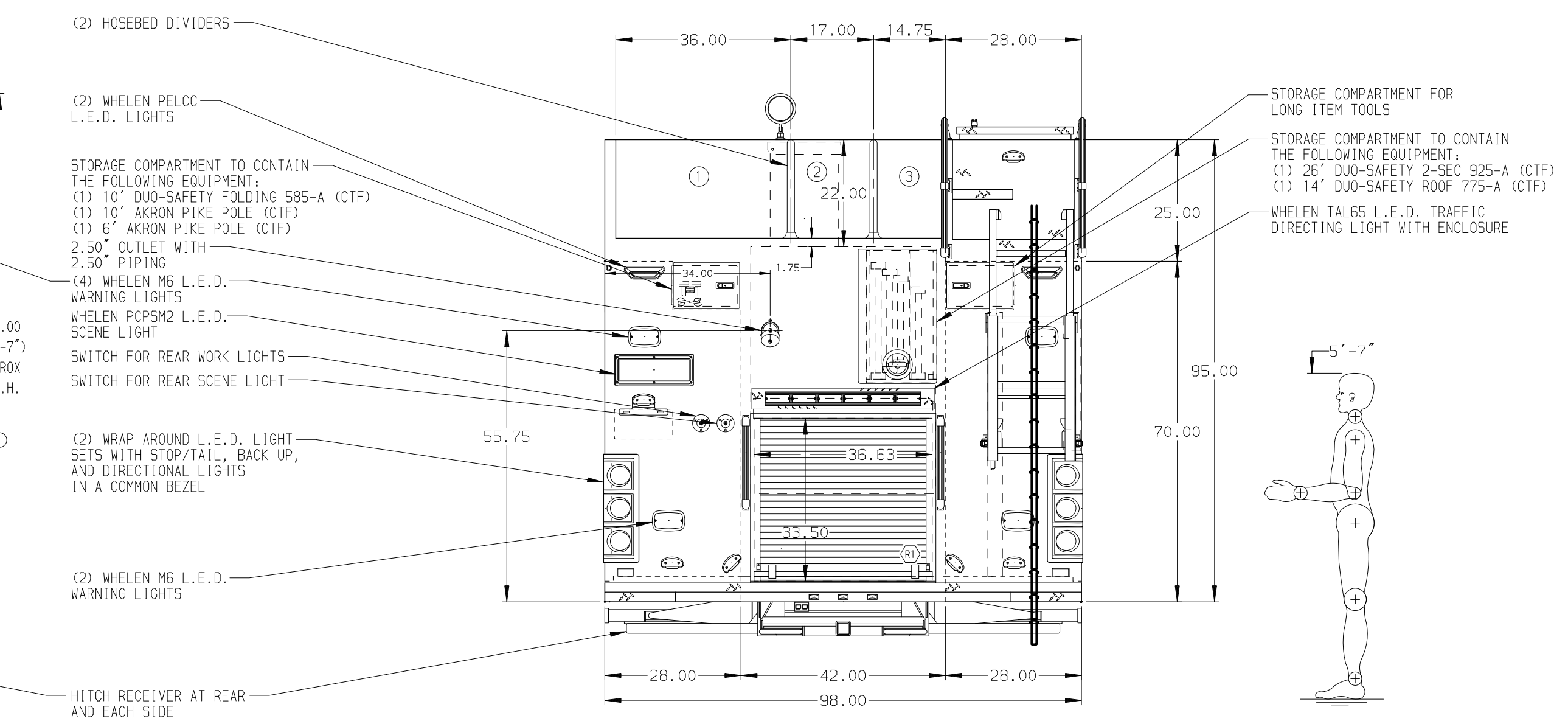
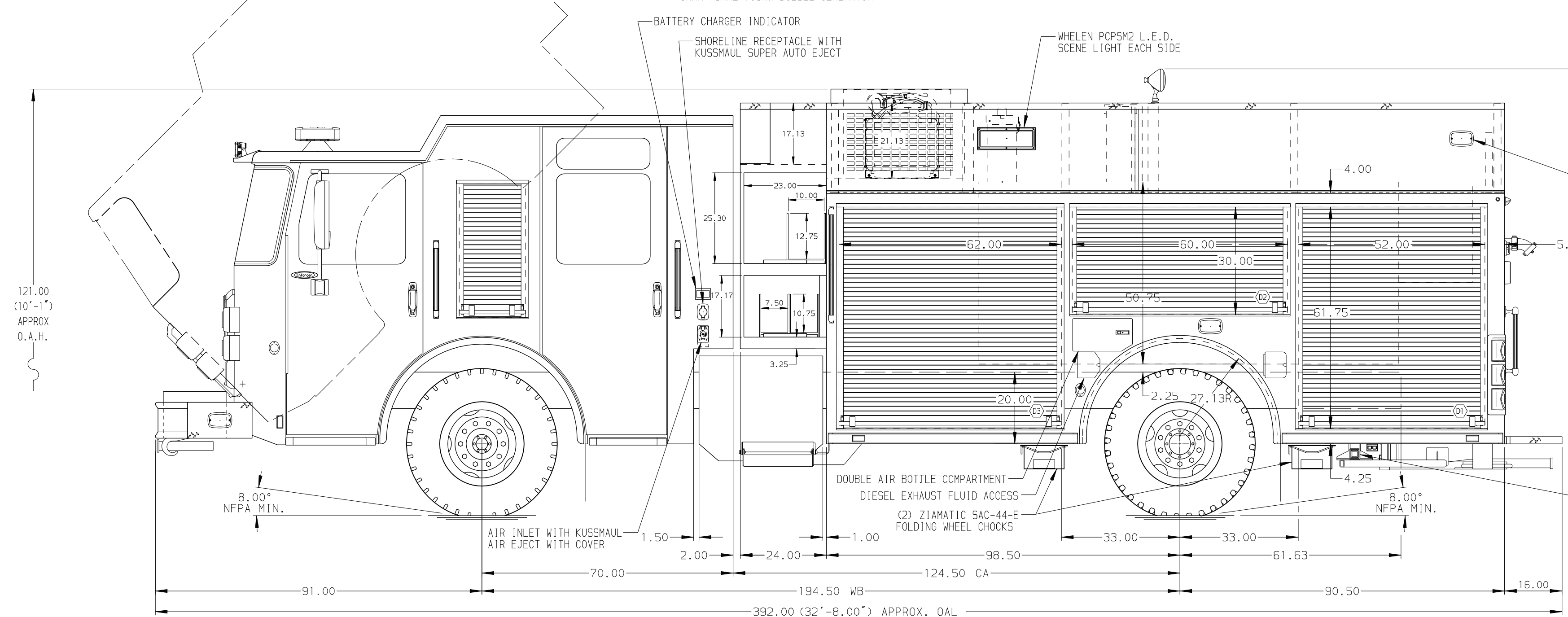

ALUMINUM BODY

NOTE
DIMENSIONS SHOWN ARE APPROXIMATE AND ARE SUBJECT TO MINOR DEVIATIONS AS MAY OCCUR OR BE NECESSARY IN CONSTRUCTION. MINOR DETAILS NOT SHOWN.

1. OIL DRY HOPPER WITH 200 LBS. OF OIL DRY ABSORBENT IN HATCH COMPARTMENT ABOVE P3
2. BATTERY CHARGER LOCATED IN COMPARTMENT-D3
3. BATTERY CHARGER INDICATOR LOCATED ON DRIVER SIDE SEAT RISER
4. FULL WIDTH/DEPTH ADJUSTABLE SHELVES WITH 2" SIDES IN COMPARTMENT-TWO IN D1,P1; THREE IN D3
5. ADJUSTABLE SLIDE-OUT TRAYS WITH 2" SIDES IN COMPARTMENT-P3,R1
6. ADJUSTABLE TILT/SLIDE-OUT TRAYS IN COMPARTMENT-D1,D2,P3
7. FULL WIDTH/DEPTH FLOOR MOUNTED SLIDE-OUT TRAYS WITH 2" SIDES IN COMPARTMENT-P1,P3,R1
8. SWING-OUT TOOLBOARD WITH PEGBOARD PATTERN IN COMPARTMENT-P2
9. VERTICAL PARTITION WITH PEGBOARD PATTERN IN COMPARTMENT-P1
10. VERTICAL PARTITION IN HATCH COMPARTMENT ABOVE P3
11. PEGBOARD WITH TRACKS ON REAR WALL IN COMPARTMENT-P1
12. PEGBOARD WITH TRACKS ON SIDE WALL IN COMPARTMENT-P1
13. CIRCUIT BREAKER PANEL IN DRIVER SIDE FRONT BRASS COMPARTMENT

REV	DATE	BY	CH	ENFORCER
30JAN17	BST	JJR		CHASSIS DATA
05JAN17	BST	JJR		MAKE
09DEC16	BST	JJR		PIERCE
03OCT16	BST	CDU		MODEL

		JOB NO.	30439
		SCALE	DATE
TITLE	1500-D-600P W/40 GAL. FOAM CELL, DELUGE, GENERATOR	DRAWN BY	BST
FOR	189" PUC RESCUE BODY, LADDERS THRU TANK, HUSKY FOAM	CHECKED BY	CDU
	CHILLIWACK FIRE DEPARTMENT	SHEET SIZE	SHEET NO.
	CHILLIWACK, AB	D	1 OF 1
DWG NO.	30439AD		