

- HOSEBED CAPACITIES
- ① - TOOL STORAGE
 - ② - 1000' OF 5.00\"/>

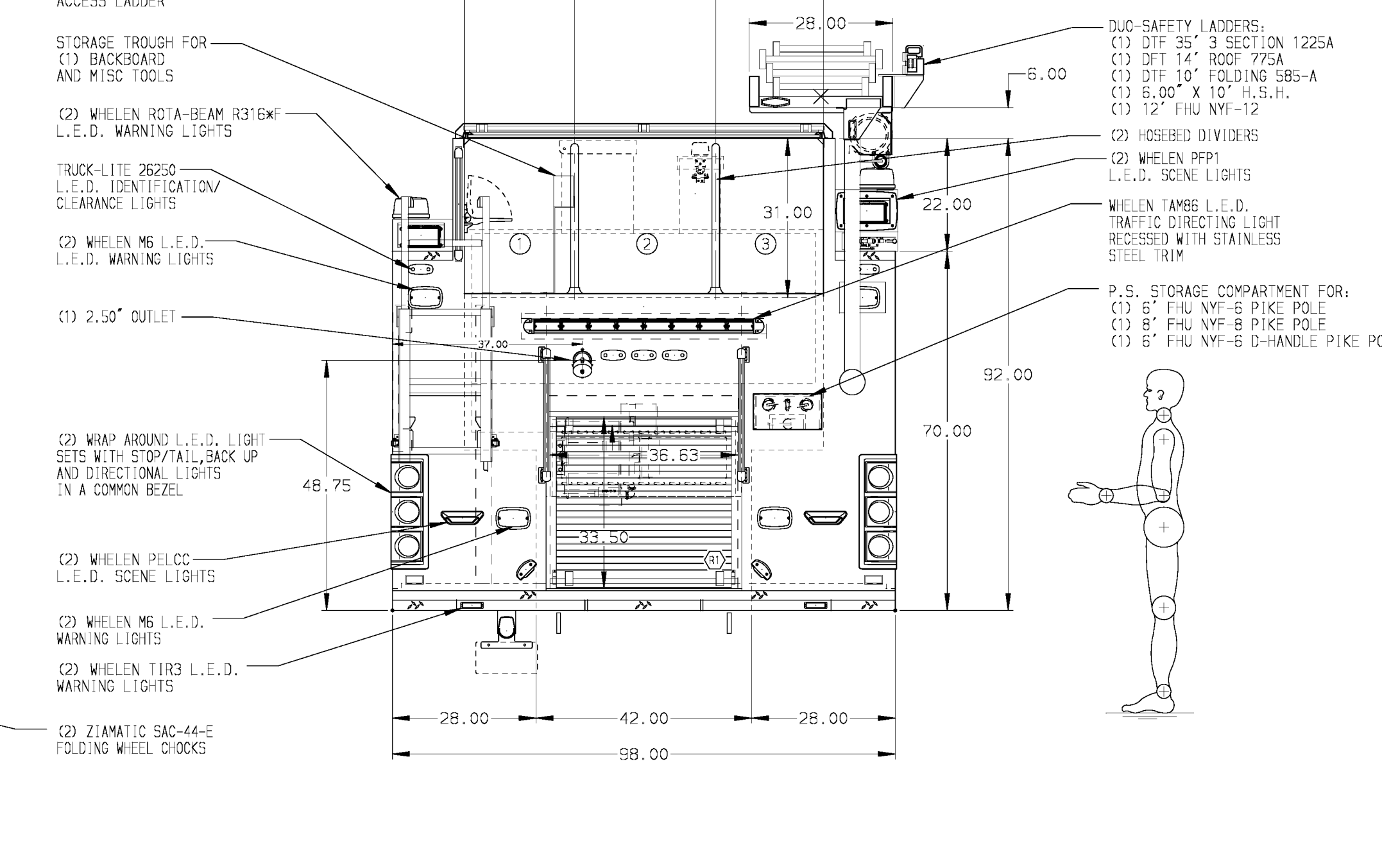

ALUMINUM BODY
 MAXIMUM O.A.H. 134"

NOTE
 DIMENSIONS SHOWN ARE APPROXIMATE AND ARE SUBJECT TO MINOR DEVIATIONS AS MAY OCCUR OR BE NECESSARY IN CONSTRUCTION. MINOR DETAILS NOT SHOWN.

1. ONE SPOT AUTOMATIC TIRE CHAINS TO BE PROVIDED AT REAR
2. ALUMINUM TREKPLATE EXTERIOR REAR WALL OF CAB
3. POLISHED STAINLESS STEEL SCUFFPLATE ON EACH CAB DOOR JAMB
4. POLISHED STAINLESS STEEL SCUFFPLATE ON REAR OUTER CORNERS OF CAB
5. BATTERY CHARGER LOCATED BEHIND DRIVER SEAT
6. ON SCENE L.E.D. COMPARTMENT LIGHTS IN ALL BODY COMPARTMENTS
7. ONE ADJUSTABLE FULL WIDTH/FULL DEPTH SHELF IN COMPARTMENT D1, D2, & P2; TWO IN D3, P1, & P3
8. ONE FLOOR MOUNTED SLIDE-OUT TRAY IN COMPARTMENT P1
9. ONE FLOOR MOUNTED SLIDE-OUT TRAY WITH 0.75\"/>

REV	DATE	BY	CH	VELOCITY
31AUG15	COL	PJP		
04AUG15	COL	PJP		

		JOB NO.	28986
		SCALE	DATE
CHASSIS DATA TITLE MAKE FOR DWG NO.	1500-D-1000P W/20 GALLON FOAM CELL, 189\"/>	DRAWN BY	26MAY15
	SOUTH METRO FIRE RESCUE AUTHORITY	CHECKED BY	27MAY15
	CENTENNIAL, COLORADO	SHEET SIZE	SHEET NO.
			1 OF 1