



Pasta Cooker  
High BTU  
CPG-1



**STANDARD FEATURES**

- Single chamber in 18/10 stainless steel.
- 304 and 316 series stainless steel construction.
- 12 gallon water capacity per tank chamber.
- Triple fiberglass insulation on all sides.
- Seamless stainless steel baskets with specially designed perforated holes.
- Multiple basket size configurations.
- Specially designed burner creates a water current flow that lifts starch carrying it out to the overflow drain.
- Automatic pilot.
- Top mount water faucet for continuous clean water flow.
- 80,000 BTU per chamber burner.
- Adjustable legs.
- A.G.A. and NSF approved.

**OPTIONS**

- Electric model.
- Double chamber.
- Triple chamber.
- Multiple basket size configuration in stainless steel.
- Automatic lift mechanism.
- Casters.

ITEM:

PROJECT:

DATE:

**Pasta Cooker  
High BTU  
CPG-1**



**Rosito Bisani**  
SPECIALTY FOOD SERVICES EQUIPMENT

**Pasta Cooker  
High BTU  
CPG-I**

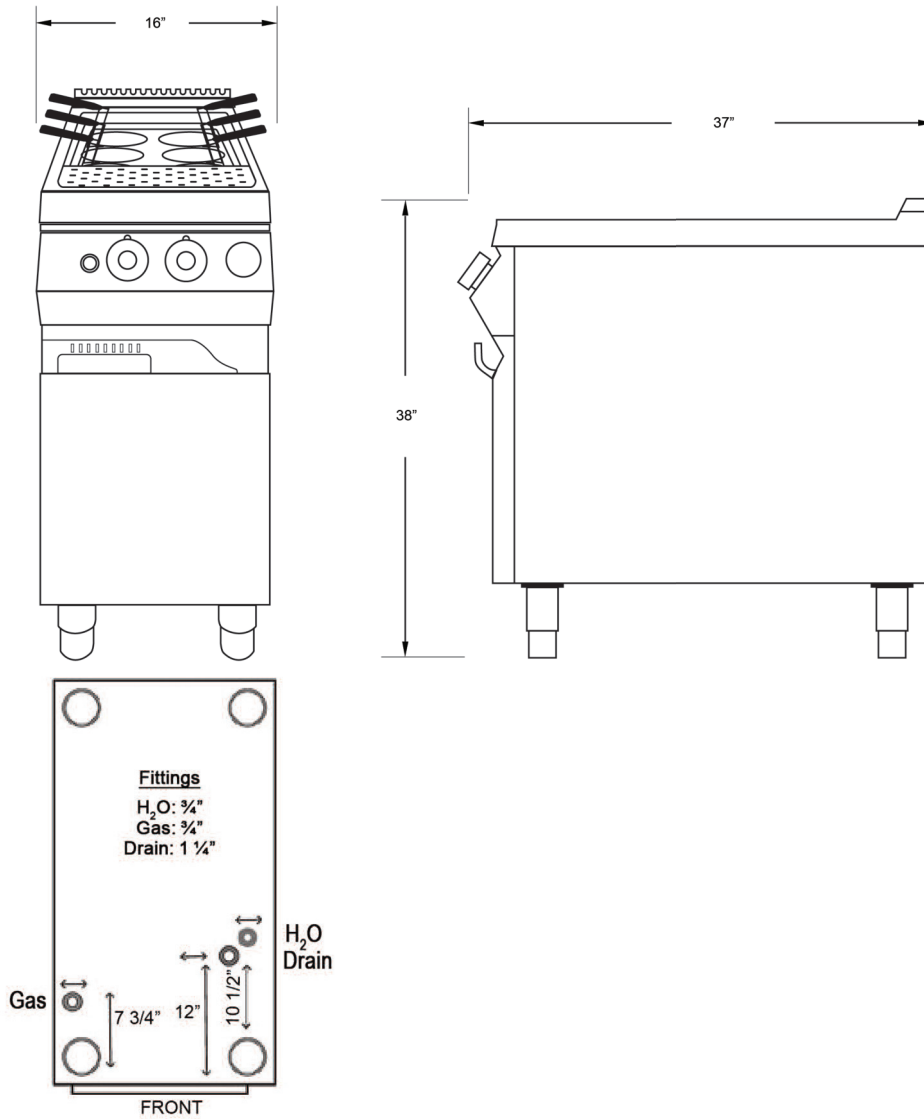

MODEL	UNIT DIMENSION W x D x H	TANK DIMENSION W x D x H	CAPACITY (GAL.)	WT.	SHIP WT.	K.W.	V.	PH.	HZ.	AMPS	H <sub>2</sub> O	GAS	DRAIN	BTU	WATER COLUMN
CPG 1 High BTU (GAS)	16" x 37 x 38	12" x 20 x 12	12 gal.	130 lbs.	160 lbs.	X	X	X	X	X	1/4"	1/4"	1 1/4"	80,000	4 1/2"



**Rosito Bisani Imports, Inc.**  
940 South La Brea Avenue, Los Angeles CA, 90036  
Tel: 323-937-1888 • Fax: 323-938-0728 • Toll Free: 1-800-848-4444  
E-mail: sales@rosito-bisani.com

[www.rosito-bisani.com](http://www.rosito-bisani.com)

530 South Henderson Road, Suite F, King of Prussia PA, 19406  
Tel: 610-265-5950 • Fax: 888-576-8524

**GAS-FIRED**



*Rosito and Bisani Imports reserve the right to make changes in design specifications and/or to make additional improvements in its products without imposing any obligations upon itself to install them on products previously manufactured. © 2013.*