

# Prysm Systems 85 Dual Visual Workplace Solution

Transform your workplace with the Prysm Systems 85 Dual Visual Workplace Solution powered by the Prysm Application Suite. Prysm Systems Visual Workplace Solutions deliver powerful features with an interface that's as easy to use as a tablet. Packed with tools that bring together people, content and ideas, they display streaming video, web apps, documents, presentations, images and inputs from laptops and mobile devices with a simple tap. Size, position and annotate any content on screen through the touch interface. Mirror up to 25 Visual Workplaces to extend real-time collaboration across multiples sites.

With Prysm Visual Workplace Solutions, you'll streamline workflow, increase productivity, accelerate decision making and change the way you work – forever.

## Features

- ▶ Two 85" 4k UHD touch LCDs
- ▶ 7680 × 2160 pixel digital canvas
- ▶ Two display stands
- ▶ One application appliance
- ▶ Extended mode – single UI across both LCDs

For more information, contact us at [sales@prysmsystems.com](mailto:sales@prysmsystems.com), or +1.408.586.1100, [www.prysmystems.com](http://www.prysmystems.com)



## Specifications

### Target Applications

Room Types	Conference rooms Team spaces Board rooms Briefing centers Training rooms Demo centers
Room Size	Small and medium rooms, 4 – 10 people
Ambient Light	Suitable for normal indoor ambient lighting conditions (avoid direct sunlight)

### Individual Display Characteristics

Display Resolution (W × H)	3840 × 2160 pixels
Refresh Rate	100/120 Hz
Max Input Resolution and Frame Rate	3840 × 2160 @ 60 Hz
Total Pixel Count	8.3 million
Display Active Area (W × H × diagonal)	73.7 in × 41.5 in × 84.5 in 1872 mm × 1053 mm × 2146 mm
Display Aspect Ratio (W/H)	16 : 9
Display Color	> 1 billion colors, 10 bit data path
Panel Brightness (typical)	500 cd/m <sup>2</sup>
Panel Contrast Ratio	3000:1
Backlight Illumination	Direct LED
Response Time (typical)	6.5 ms
Pixel Pitch	0.49 mm × 0.49 mm
Ideal Viewing Distance	3 – 30 ft 1 – 10 m
Display Dimensions (W × H × D, with handles)	75.8 in × 43.6 in × 4.7 in 1926 mm × 1108 mm × 119 mm
Cover Glass	Cover Glass Corning® Gorilla® glass Chemically-strengthened, 2mm Zero air gap
Touch Type	High-resolution IR
Touch Points	12 simultaneous touch points
Touch Resolution	Sub-pixel
Touch Update Rate	200 fps
Touch Latency	5 – 10 ms
Touch Accuracy	2.7 mm
Audio	Two rear facing speakers, 10 W each

### Application Appliance (X30)

Video Output	NVIDIA® Quadro® P1000 (4x Mini Display Ports)
Video Capture/Input <sup>1</sup>	4x HDMI 1.4a
Processor	Intel® Xeon E3 1270
Storage	256 GB SSD
Dimensions (W × H × D)	8.5 in × 2.3 in × 8.5 in 215.9 mm × 58 mm × 215.9 mm

<sup>1</sup> HDMI inputs accept HDMI live source inputs at 720p @ 60 Hz and 1080p @ 60 Hz, such as laptops, tablets, VTC, HDTV, etc. Does not support HDCP.

...continued on reverse

## Prysm Systems 85 Dual Visual Workplace Solution

Environmental	Display	Application Appliance
Weight	234.4 lbs, 106.3 kg	16.0 lbs, 7.2 kg
Power Consumption	Max: 520 W Typical: 450 W Standby: ≤ 0.5 W	Max: 155 W Typical: 130 W Sleep: 2.1 W
Heat Output	Max: 1774 BTU/hr Typical: 1535 BTU/hr	Max: 890 BTU/hr Typical: 444 BTU/hr
Operating Temperature	41 – 104°F 5 – 40 °C	40 – 95 °F 5 – 35 °C
Storage Temperature	-4 – 140°F -20 – 60 °C	-40 – 140 °F -40 – 60 °C
Humidity (non-condensing)	Up to 90% RH	Up to 85% (operating)
Power Supply	100 – 240 VAC	100 – 240 VAC
IP Rating	50	50

### Regulatory

FCC	FCC CFR Title 47 Part 15 Subpart B: Class A, CISPR 22 ANSI C63.4 ICES-003 Issue 5
CE	EN 55022, EN55024,  EN 61000-3-2, EN 61000-3-3
cTUVus	UL 60950-1 CAN/CSA-C22.2 NO.60950-1-07
CB	IEC 60950-1
CCC	GB9254, GB4943.1, GB17625.1
CEL	GB21520

### Individual Display Stand/Cart

Exterior Width (max)	48.0 in, 1220 mm
Exterior Depth (max)	24.5 in, 623 mm
Weight	120.0 lbs, 54.4 kg
Included Parts	Camera tray, accessories tray and castors

### Appliance Cabinet

Dimensions (W × H × D)	30.0 in × 20.3 in × 5.1 in 762 mm × 516 mm × 129 mm
Weight	28.5 lbs, 12.9 kg

### Wall Mount

VESA	500 mm × 400 mm 500 mm × 600 mm
------	------------------------------------

### Clearances

Minimum Ceiling Height	96.0 in, 2438 mm
Display Start Height	33.0 in, 838 mm Add 2.5 inches, 76 mm for castors
Required Clearances - Passive Ventilation	Front: 12.0 in, 300 mm Rear: 8.0 in, 200 mm

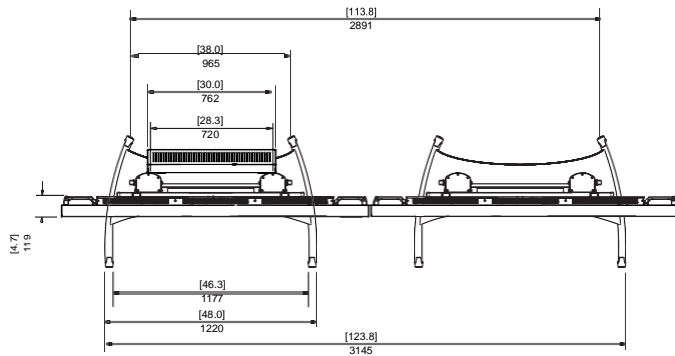

Plan View

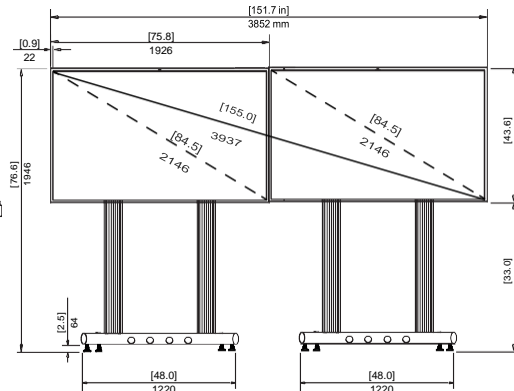

Front Elevation

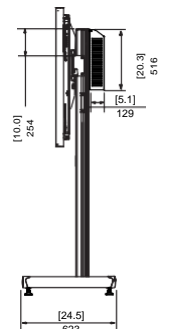

Side Elevation

Dimensions [in] mm

### Disclaimer:

The information contained herein is subject to change without notice. The only warranties for Prysm Systems products and services are set forth in the express warranty statements accompanying the applicable customer agreement. Nothing herein should be construed as constituting an additional warranty. This document is provided solely for general informational purposes. Prysm Systems shall not be liable for technical or editorial errors or omissions contained herein. Video wall display characteristics may vary from the tile display characteristics specified herein based upon factors including, but not limited to, the size of the video wall and display configuration settings. All trademarks mentioned are the property of their respective owners.