

6

5

4

3

2

1

REV	ZONE	ECN	REVISION DESCRIPTION	DATE	ENG
A	Released	03/04	DC

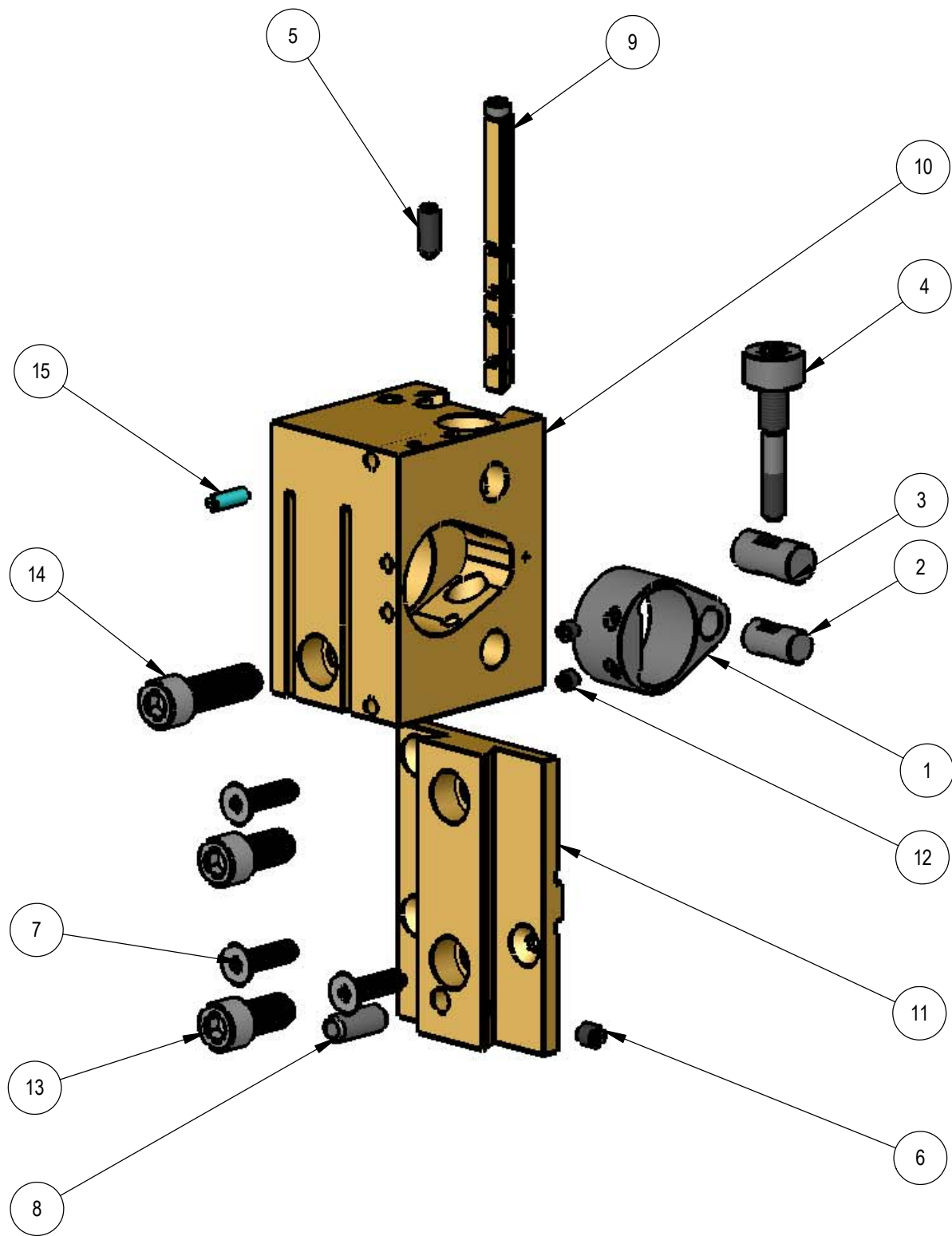

ITEM NO.	PART NUMBER	DESCRIPTION	QTY.
1	111007	Taper Arm - 3rd Position	1
2	111008	Taper Pin (Arm)	1
3	111009	Taper Pin (Body)	1
4	111010	Taper Adjustment Screw	1
5	111023	Screw: SSS, #10-32 x .500 Cup Pt.	1
6	111024	Screw: SSS, #8-32 x .250 Flat Pt.	1
7	111026	Screw: FHCS, #10-32 x .750	3
8	111028	Pin: Dowel, 1/4 x .625	1
9	111059	Locking Gib - 1st & 3rd Position	1
10	111201	Tool Block	1
11	111202	Dovetail Adapter Plate (3rd)	1
12	125043	Screw: SSS, #8-32 x .188 Cup Pt.	2
13	130046	Screw: SHCS, 5/16-24 x .625	2
14	130047	Screw: SHCS, 5/16-24 x 1.000	1
15	NC41029	Spring Plunger #8-32 Short, Heavy Force	1

THIS DRAWING IS THE CONFIDENTIAL AND EXCLUSIVE PROPERTY OF C.J. WINTER MACHINE TECHNOLOGIES, INC. AND MAY NOT BE COPIED, REPRODUCED, OR DISCLOSED IN ANY WAY, WHATSOEVER TO ANYONE WITHOUT THE EXPRESS WRITTEN PERMISSION OF C.J. WINTER MACHINE TECHNOLOGIES, INC UNLAWFUL DISCLOSURE MAY RESULT IN PROSECUTION

UNLESS OTHERWISE SPECIFIED:
DRAWING MUST COMPLY TO
C. J. WINTER ENGINEERING
STANDARD E1058 & ASME
Y14.5M 1994. UNTOLERANCED
DIMENSIONS ARE BASIC

DRAWN BY: D. Cole
DWG DATE: 03/17/04
ENG. APPR:
APPR DATE:
MATERIAL:
HEAT TRT:



DWG SIZE
B
SCALE: 1:1.5
SHEET 1 OF 1

3rd Position Tool Block Assembly

DRAWING NO.
111-12

6

5

4

3

2

1