



Gunnebo SafePay Complete

High security and optimization of cash management in your store

GUNNEBO[®]



Highly secure and efficient way to manage your cash in store

SafePay offers customers a quick and efficient way to pay with cash in any type of store. Cashiers are relieved of time-consuming back-office cash administration as cash is automatically checked and counted and cash totals are monitored online via our Cash Control Software.

From the moment your customers pay until cash is deposited into the bank, your earnings are kept safe and cash operations are optimized, since cash is never exposed or handled manually and no staff member has to be present during CIT pick up.

Daily earnings are transported securely into a sealed cassette from the check-out to the back office at the

end of the day. Ink protection can be added into transportation sealed cassettes for extra security. Transportation cassettes are slotted into the back-office deposit unit and automatically emptied. Notes in back-office deposit unit can be stored into a thermally sealed plastic bag or into an armed CIT case.

No matter the space you have in the check-out, SafePay Complete will meet your needs. With the Slim Edition you will have the thinnest front-end recycling system of the market. Your staff will be happy to leave on time and you will be content knowing that everything is running as it should be as all processes are also controlled by the highly technologically advanced Cash Control software.

Benefits at a glance

1

Closed and controlled Cash Handling at check-out

2

Extensive in-store security in front and back office

3

Pre-Crediting integration

4

Simple staff maintenance

5

Designed for self-service or cashier operation

Product Features



Multiple Configurations

- SafePay Complete
- SafePay Complete – Slim Edition
- SafePay Complete ink
- SafePay Complete ink – Slim Edition
- All SafePay families can be customized with the color of your choice



Easy to use

- Enhanced note insertion
- Graphical display for clear communication with your customers
- Adapted for disability access
- Multiple currencies
- Equipped for cash back



Closed and secured system

- Cash never exposed
- Grade III back-office deposit unit for overnight storage
- Transportation sealed cassettes can be ink-protected
- ECB certified authenticity control
- Floor anchored for physical protection



Streamlined investment

- Allow multiple POS configurations up to 5 POS per SafePay
- Optimization of end-to-end cash process
- Cash reporting and automatic reconciliation
- Remote Service Monitoring
- Desktop and Mobile web-based platform for centralized control – Cash Control



Simple Maintenance

- Staff can solve problems quickly themselves
- Plug&Play replacement of key parts
- Remote problem solving through Cash Control
- Problem solving routines clearly displayed on standard POS screen and Cash Control based platform for centralized control

Technical Data

| | Complete | Complete - slim edition | Complete ink | Complete ink - slim edition |
|----------------------------|---|---|---|---|
| Dimensions (L x W x H) in. | CR : 13 x 12 x 25 | CR : 18 x 5 x 51 | CR : 13 x 12 x 25 | CR : 18 x 5 x 51 |
| | NR : 8 x 19 x 29 | NR : 8 x 19 x 29 | NR : 8 x 19 x 29 | NR : 8 x 19 x 29 |
| Weight | 168 lbs. | 216 lbs. | 168 lbs. | 216 lbs. |
| Speed – notes | approx. 1 note per sec | approx. 1 note per sec | approx. 1 note per sec | approx. 1 note per sec |
| Speed – coin deposit | 5 coins per sec | 2 coins per sec | 5 coins per sec | 2 coins per sec |
| Speed – coin dispensing | avg. 6 coins per sec | 3,5 coins per sec | avg. 6 coins per sec | 3,5 coins per sec |
| Coin bulk capacity | 200 coins | 25-75 coins | 200 coins | 25-75 coins |
| Storage – notes | up to 800 | up to 800 | up to 800 | up to 800 |
| Storage – coins | 3.000 mixed denominations | 100 – 1.000 per denomination | 3.000 mixed denominations | 100 – 1.000 per denomination |
| Voltage | 230V | 230V | 230V | 230V |
| Connections | RS232, RS485, Ethernet LAN, Power 24V DC input / output | RS232, RS485, Ethernet LAN, Power 24V DC input / output | RS232, RS485, Ethernet LAN, Power 24V DC input / output | RS232, RS485, Ethernet LAN, Power 24V DC input / output |
| Currencies | EUR, GBP, SEK, NOK, DKK, PLN, ZAR, MXN, RM, CHF, THB, SGD, AUD, USD | EUR, GBP, SEK, NOK, DKK, PLN, ZAR, MXN, RM, CHF, THB, SGD, AUD, USD | EUR, GBP, SEK, NOK, DKK, PLN, ZAR, MXN, RM, CHF, THB, SGD, AUD, USD | EUR, GBP, SEK, NOK, DKK, PLN, ZAR, MXN, RM, CHF, THB, SGD, AUD, USD |

Security

- Authenticity control
- Optional ink protection
- Floor anchoring
- Prevention from robberies and shrinkage
- Coin module with key lock or dual key lock
- Full event logging including potential fraud attempts

Application Areas

- Traditional check-outs
- Self-service check-outs
- Self-Payment stations
- Mid and Large-sized stores

Options

- Multicurrency support
- Deposit capacity from 400 to 800 notes
- Recycling capacity from 100 notes (all denominations) up to 900 notes

Product Drawings

Note Recycler Interface Cassette

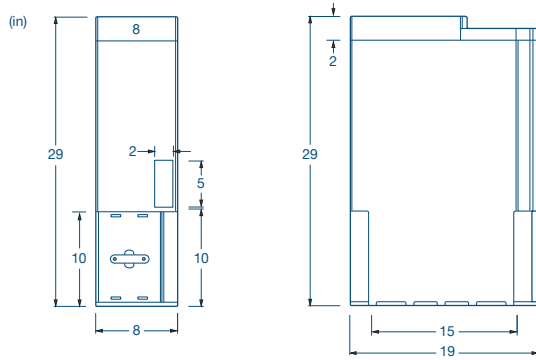

Coin Recycler - Slim Edition

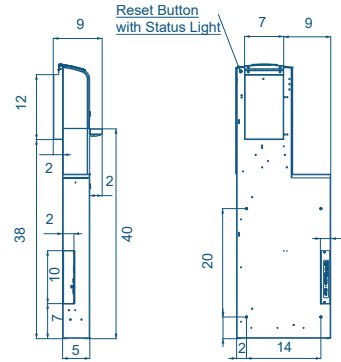

Coin Recycler

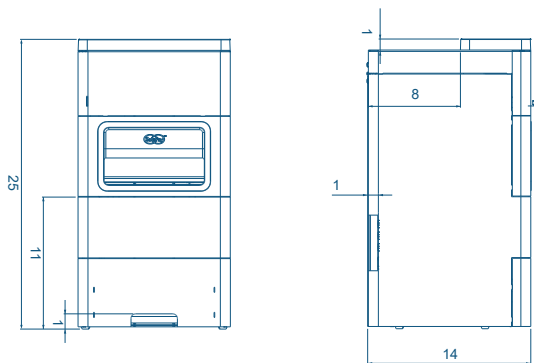

About Closed Cash Management

SafePay Complete forms part of the SafePay closed cash management solution for retailers. Closed cash handling protects cash from the moment a customer pays all the way to the cash-counting center – no gaps in security and no weak links in the chain. It replaces manual tills with a much more secure system which recycles cash and removes cash differences. Gunnebo is a pioneer in this field and has worked closely together with leading European retailers to develop SafePay – a reliable, secure and efficient closed cash handling system.



Want to see SafePay Solutions in full action?
Scan this QR code with your smartphone.
Or search for "SafePay" on YouTube.

Gunnebo SafePay Complete



Hamilton Security
7775 Cooper Road, Cincinnati, OH 45242
Tel 513.874.3733. www.gunnebo.us

