

**Concepts** **NREC**

The Experts in Turbomachinery

CAM Software

**MAX-PAC™**  
Computer-Aided Manufacturing Software

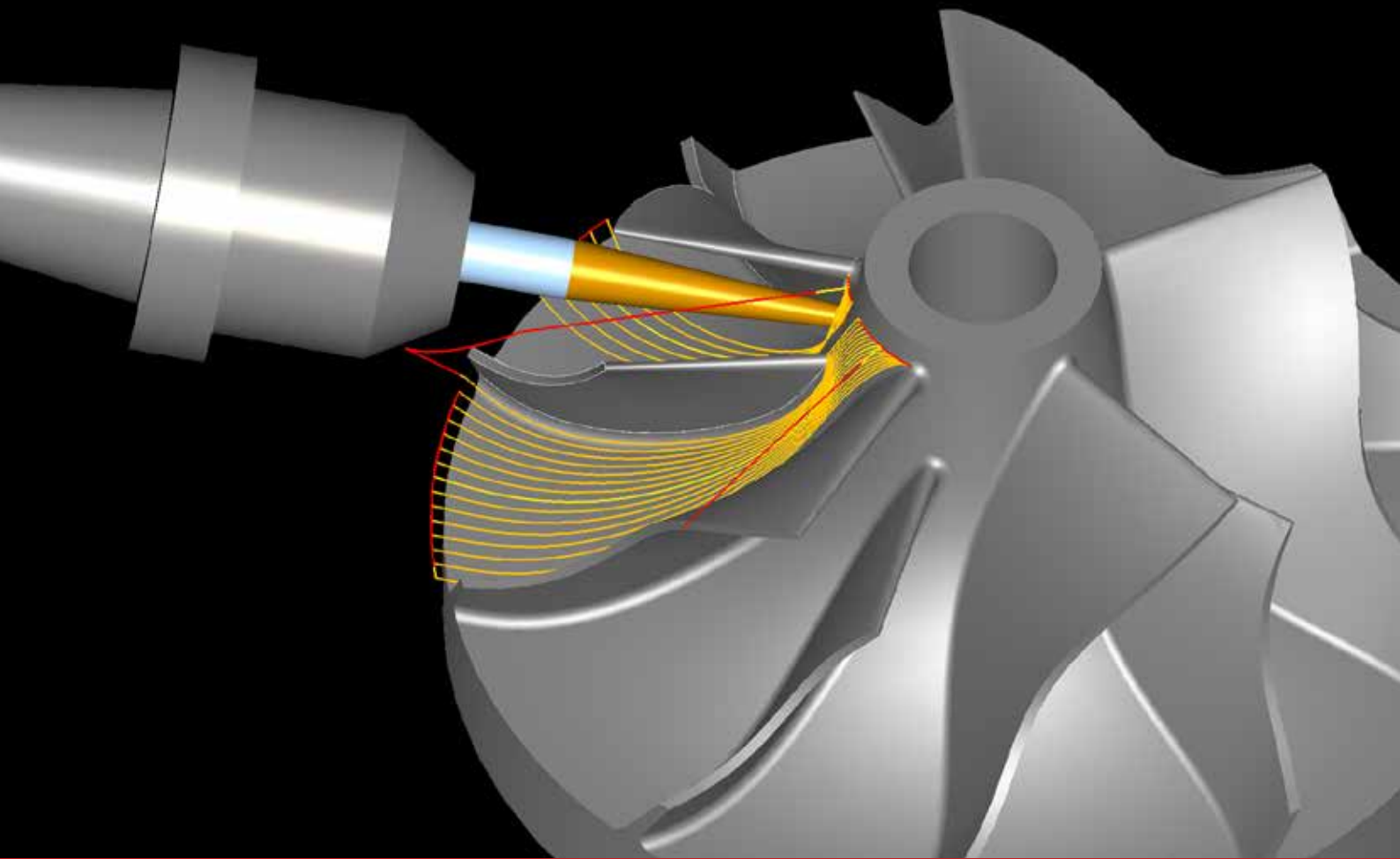

• Engineering • Software • Manufacturing • Training

# Concepts NREC

For over 60 years, Concepts NREC has been partnering with the world's leading OEMs to improve the performance and manufacturability of turbomachines. We are the only company in the world whose in-house capabilities span the entire process — from conceptual design through manufacturing, testing, and installation. This unique perspective creates powerful synergies that drive innovation across our entire offering. Our clients benefit from having a trusted partner who can see the big picture and provide valuable insights that save them time and money.

We are ISO 9001:2015 and AS9100:2016 certified and committed to providing our customers with products and services that meet international quality standards.

## Advancing the State of the Art in Turbomachinery

Concepts NREC maintains a robust in-house research and development program. We hold over 70 patents worldwide, with numerous patents pending. Concepts NREC is also the leader of the global *Advanced Centrifugal Pump and Compressor Consortium for Diffuser and Volute Design*, an internationally sponsored research venture dedicated to advancing diffuser and volute design.

We push past what *has* been done to explore what *can* be done. Concepts NREC has the vision to create great designs and a hard-earned reputation for delivering them.

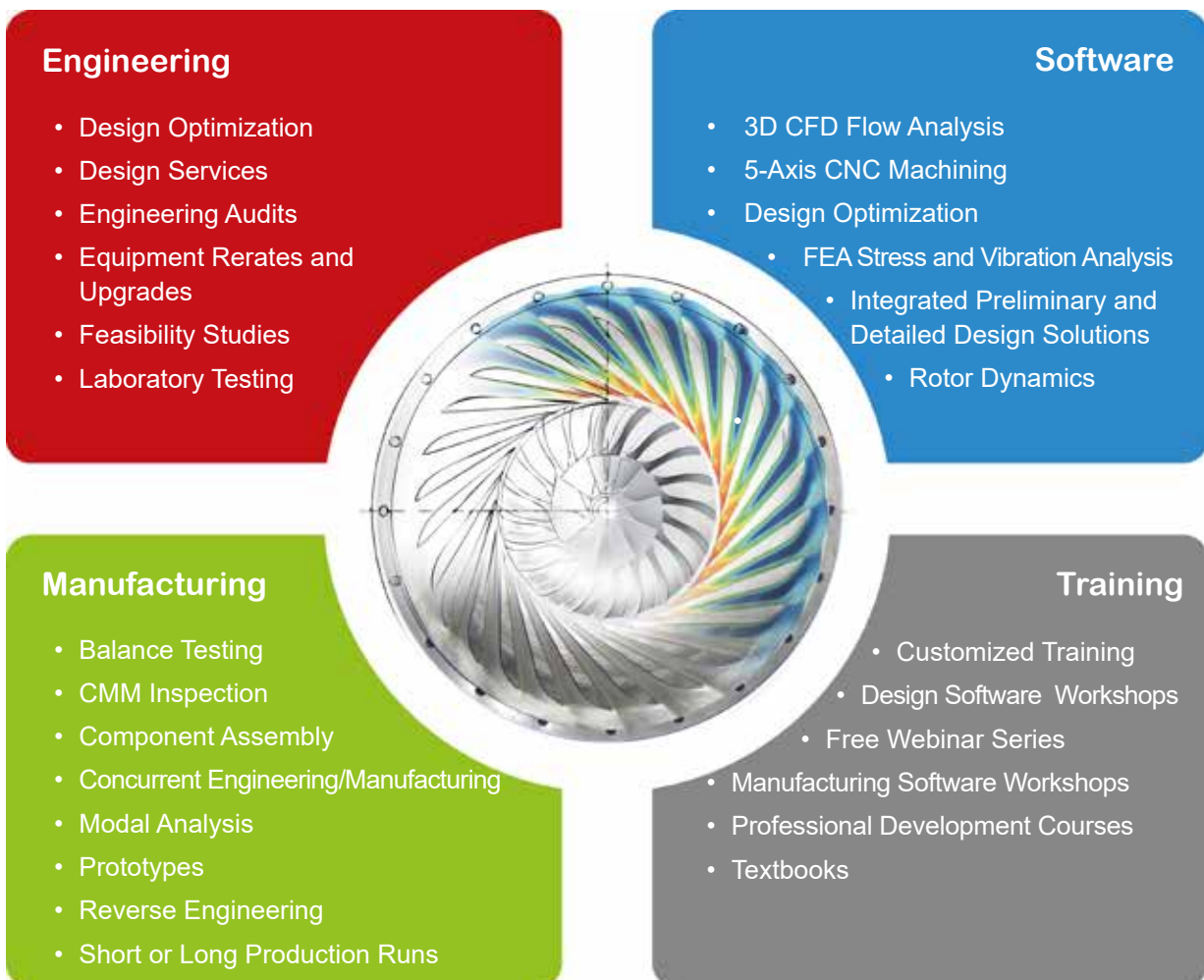

## Industry-Leading Software Suite

The Agile Engineering Design System® is a complementary suite of programs for Computer-Aided Engineering (CAE) and Computer-Aided Manufacturing (CAM). The seamlessly integrated CAE modules cover the entire design process — from preliminary sizing through fluid dynamics and mechanical stress and vibration analysis. Final designs can be easily transferred to our CAM software, MAX-PAC, to create efficient 5-axis machining strategies.

### MAX-PAC — Specialized for Turbomachinery

Based on decades of experience, and incorporating several patented methodologies, MAX-PAC is recognized as the best software for 5-axis milling of turbomachinery impellers, blisks, and rotors. MAX-PAC is used worldwide by turbomachinery manufacturers, job shops, and 5-axis machine-tool manufacturers who are passionate about producing the highest quality parts.



### Machine Parts Better, Faster, Cheaper

Manufacturing turbomachinery components is often a challenge, due to hard materials, thin blades, tight tolerances, smooth surface-finish requirements, or difficult tool access. MAX-PAC was built from the ground up to address these challenges and enables users to produce high-quality components in less time and at a lower cost.

Compared to other general CAM tools, MAX-PAC is faster to learn, easier to use, and requires less programming and machining time. MAX-PAC offers a choice of cutting strategies to meet specific milling requirements.

### MAX-PAC Advantages

- Specialized for turbomachinery production
- Easy and fast to learn with intuitive user interface
- Supports a broad selection of tool geometries
- Faster machining times with optimized cutting strategies
- Smooth 5-axis toolpaths for high-speed milling
- Collision-free toolpaths for difficult geometries
- Superior surface finish and tight tolerances using a patented flank- or point-milling approach
- Produces high-quality parts that don't require hand finishing or other reworking

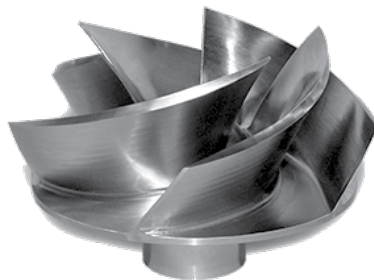

## MAX-PAC Milling Modules

MAX-PAC offers several add-on modules, each focused on a different milling strategy. Clients can purchase any combination of these modules to meet their specific machining requirements.

### MAX-5™ for Flank Milling

Flank milling efficiently finishes the entire blade surface with one pass using the side of the cutter. MAX-5 creates 5-axis CNC machining instructions for flank milling of ruled-surface turbomachinery components. Typical applications include parts for centrifugal compressors, pumps, inducers, fans, turbochargers, stators, radial-inflow turbines, expanders, and torque converters.

With MAX-5's patented algorithm, dramatic cost savings can be realized using ruled-surface designs and flank-milling. Compared to other CAM systems, MAX-5 is often capable of generating flank milling toolpaths with an 80% to 90% error reduction.

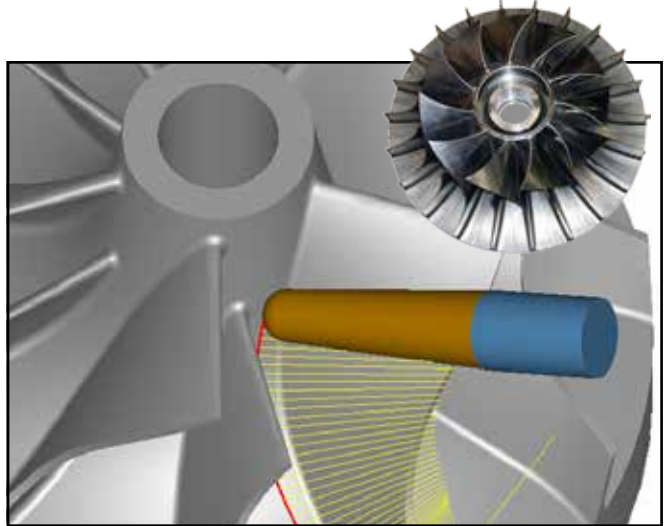

MAX-5 supports ruled blade surfaces with optional non-ruled edge constructions. It also includes options for roughing, plunge milling, hub finish, flank-milled blade finish, leading edge, fillet finish, and tip milling.

### MAX-AB™ for Point Milling

Point milling of turbomachinery components uses the tip of the tool to machine arbitrary (free-form) blade surfaces. Typical applications include axial compressors and turbines, pumps, compressors, turbochargers, radial-inflow turbines, and inducers.

MAX-AB creates smooth 5-axis machining instructions that are compatible with high-speed milling applications. MAX-AB is generally applied to the class of components that are designed with arbitrary surfaces, but it can also be used with a high-speed milling process for ruled-surface components. MAX-AB is particularly suited to today's CFD-influenced blade shapes that can be difficult or impossible to cut with other general CAM systems.

MAX-AB includes advanced capabilities for roughing, plunge milling, hub finish, point-milled blade finish, leading edge, fillet finish, and tip milling. Both spherical-shaped and barrel-shaped tool-tips are supported.

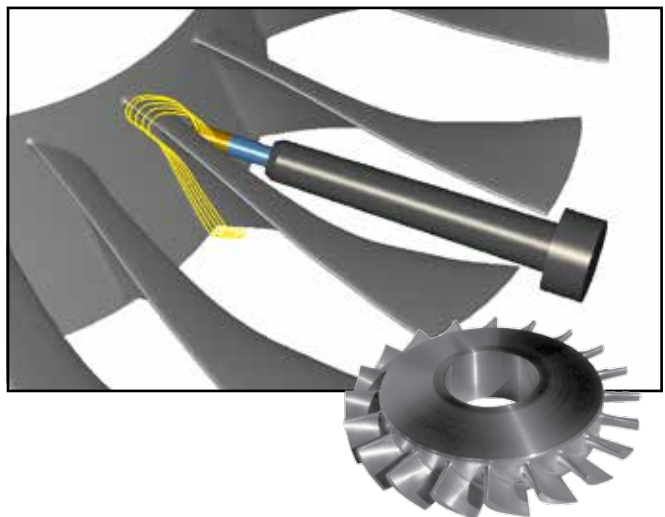

## MAX-SI™ for Integrally Shrouded Impellers

One-piece shrouded (enclosed) impellers provide many advantages over parts produced as an assembly of separate hub and shroud components (or even individual blades). The advantages include less raw material and fewer manufacturing process steps. Also, integrally shrouded components avoid heat distortion and have stronger shroud joints than fabricated assemblies.

MAX-SI creates 5-axis CNC instructions for milling integrally shrouded turbomachinery components for expanders, pumps, compressors, and turbines. It can also generate machining instructions for large axial compressors and blisks, using a side-entry machining approach.

MAX-SI includes strategies for pocket roughing, plunge milling, box passes for finish/semi finish, and flow-direction finish milling.

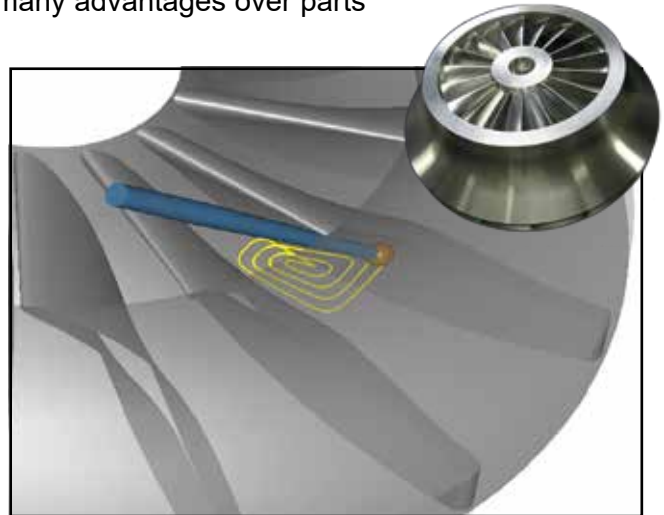

## MAX-SB™ for Single Blades

MAX-SB generates toolpaths for quickly machining single blade parts with smooth 5-axis motion. It is specifically designed for flat/torus cutters that are more efficient than a ball tool. MAX-SB also provides optimized angles for the smallest cusps, to avoid gouging in concave areas.

MAX-SB uses 5-axis milling for efficient material removal, but 4.5- and 4-axis cutting is also possible. Single blade parts are fixtured with the stacking axis aligned with the machine rotary axis.

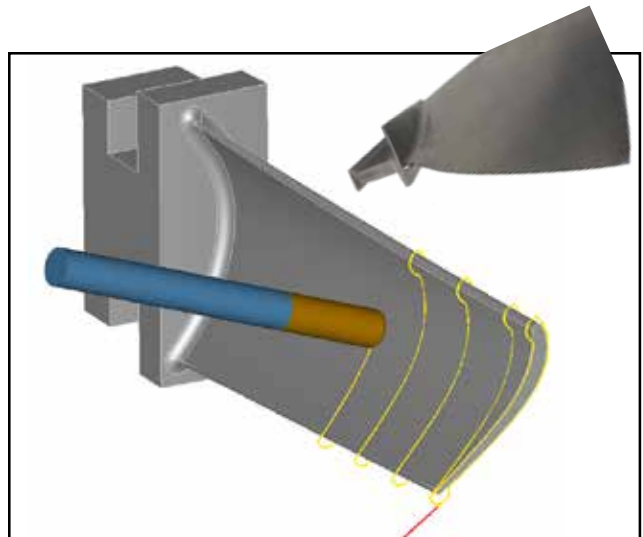

## 3+2 Roughing Module

The 3+2 Roughing Module enables the creation of 3-axis roughing toolpaths at an arbitrary angle with planar roughing levels. It optimizes the toolpath to provide a constant cutting load, making it suitable for high-speed machining. Rounded corners and helical inserts between levels are supported. Stock awareness also cuts only the material remaining from previous operations.

The 3+2 Roughing Module provides an extremely useful roughing alternative for large impellers and/or hard materials, and can be applied to impellers, blisks, and shrouded wheels.

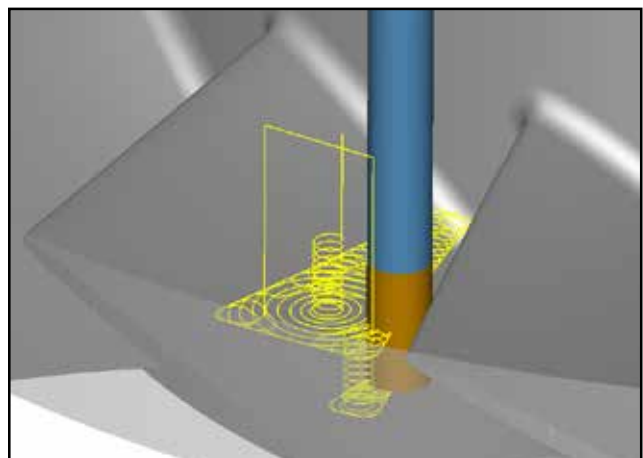

# MAX-PAC Features

MAX-PAC and its add-on modules share these advanced features:

## User-Friendly Interface

The MAX-PAC interface allows even the novice to become a power user. It guides the programmer to enter machining operations and specify parameters for each operation. Input values are checked for validity, and on-line help is available. Inputs are stored and can be used for similar applications.



## Geometric Modeling

MAX-PAC can be applied to a wide range of turbomachinery components, including centrifugal and axial bladed parts. The software can scale components, rotate coordinate systems, and create many turbomachinery-specific design constructions as required. These can include leading- and trailing-edge shapes, constant and variable-radius fillets, and blade thinning. Splitter blades are also supported. The part model can be exported in IGES format ready for CAD systems.

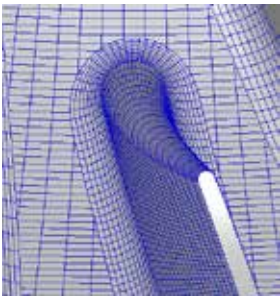

## Cutter Geometry

MAX-PAC can specify cutter shapes that include cylindrical and conical ball end mills, flat mills, corner-radius mills, plunge mills, barrel cutters, and burr (lollipop) cutters. The cutter holder/spindle geometry can also be specified for collision checking. The tools are defined with graphical 2D and 3D display. A master tool library can also be created to easily import existing tool definitions to a new case.

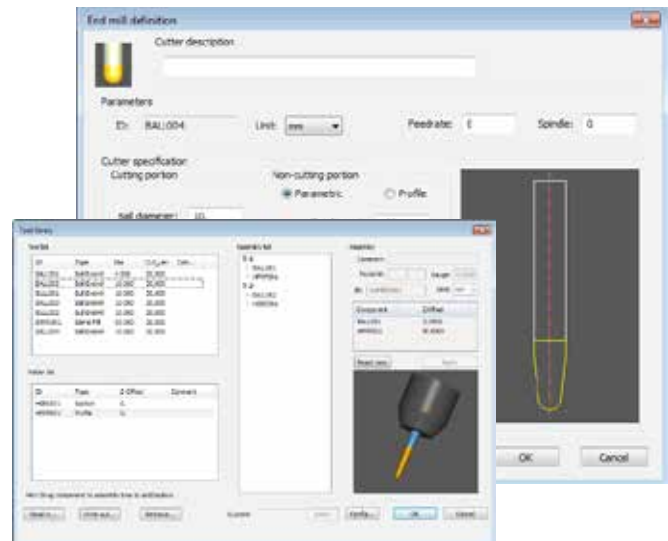

## Automatic Tool Selection

MAX-PAC can select cutter sizes from a cutter catalog for each operation, or confirm user-specified cutters. The cutters are checked against specific parameters, such as operation depth and stock offsets. To optimize material removal, the program selects the largest cutter that will fit in the specified blade pocket.

## Data Conversion

MAX-PAC can import many different tabular engineering data formats, such as camber line and thickness definitions, as well as non-streamline data grids. An optional *CAD Translator* module is also available for importing CAD files.

## Multi-Axis Output

MAX-PAC generates continuous 5-axis toolpaths that are required for most turbomachinery components. When the part geometry permits, 4.5-axis, 4-axis, and 3-axis toolpaths can also be generated.

## Milling Strategies

MAX-PAC offers toolpath templates, derived from years of experience and customer feedback. Depending on the licensed module, strategies are available for roughing, hub finish, blade finish, leading edge, variable fillet, tip chamfer, deburring, and shrouded pocket milling. Programmers select the method, cutter size, step-over specifications, and material stock, and then MAX-PAC automatically generates the cutter paths. There is no need to also construct complicated drive surfaces.

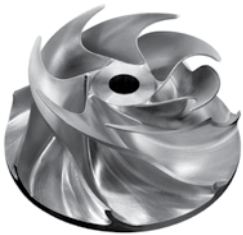
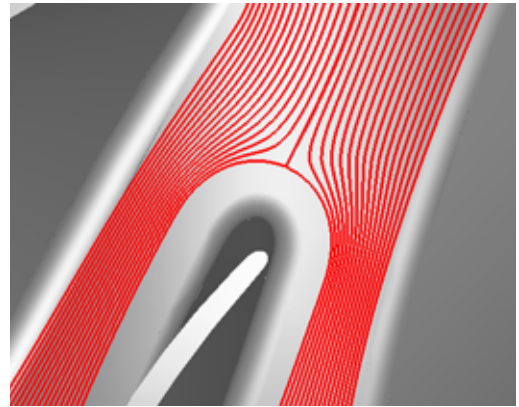

## Tool Orientation

MAX-PAC includes a patented collision detection and avoidance module. This ensures smooth, collision-free machining instructions. Tool orientation relative to the path is controlled for favorable roughing and finishing conditions. MAX-PAC's algorithm allows larger cutters for more efficient milling, and it often can produce a toolpath for difficult blade shapes that cannot be processed with general CAM systems. Cutter orientations are also automatically calculated by the program, which provides a major programming productivity improvement over other CAM systems.

## Material Removal Simulation

MAX-PAC's toolpath simulation includes material removal mode that shows the remaining stock condition and details like machining cusps. The simulation checks for collisions between tool holders and the virtual milled model. The tool tip path can be displayed, along with analysis modes, to display tool vectors, drag/drill angles, and rotary axis reversals. The animation uses a fixed-part reference or a patented fixed-cutter reference.

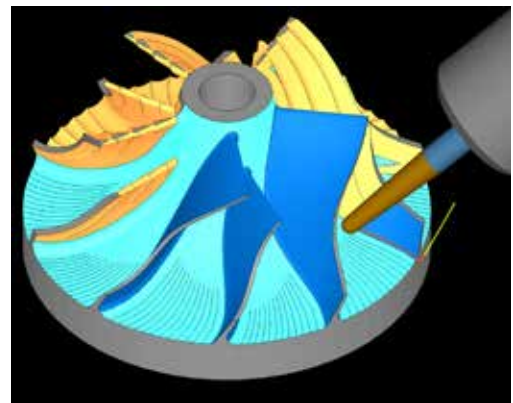

## Machine Compatibility

Standard output from MAX-PAC contains APT GOTO commands that are compatible with commercially available postprocessors. Direct postprocessors can also be developed upon request and include custom commands for each user.

## Integration with Concepts NREC's AxCent® Blade Design Software

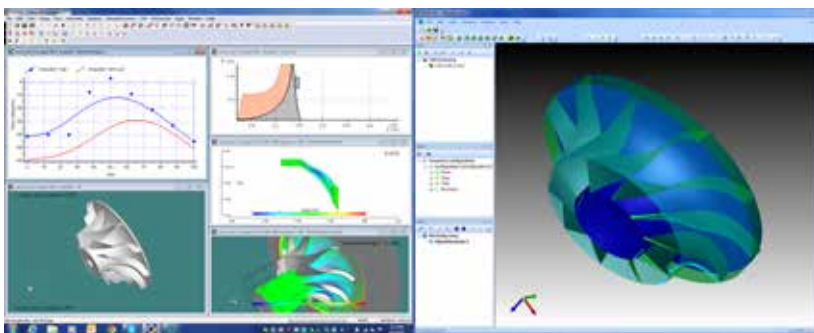

A key benefit for customers who design impellers, blisks, and single blades with AxCent is the seamless link between our design and manufacturing software. With just a single button click, the entire geometry can be transferred from AxCent to MAX-PAC. This enables designers using AxCent to quickly determine manufacturing feasibility and reduce the cost of each part. This unique, one-click functionality eliminates

the time-consuming process of transferring designs from a design system or CAD model to CAM. It also removes the risk of associated errors that can happen during the manual transfer of geometry.

# Concepts NREC

The Experts in Turbomachinery



★ Worldwide and regional headquarters. We also have sales offices and representatives strategically located throughout the world to support our global clients.

## We Offer

- CAE Software
- CAM Software
- Design Audits
- In-house Laboratory Testing
- Manufacturing Services
- Precision Prototypes
- Research and Development
- Scoping Studies
- Specialized Products

## Our Focus

- Air Dynamometers
- Compressors
- Fans and Blowers
- Gas Turbines
- ORC Turbine Generators
- Pumps
- Steam Turbines
- Superchargers
- Turbochargers

## Concepts NREC

Corporate Headquarters  
217 Billings Farm Road  
White River Junction, VT 05001

**Phone:** +1 802-296-2321

**Email:** [info@concepts-nrec.com](mailto:info@concepts-nrec.com)

**[www.concepts-nrec.com](http://www.concepts-nrec.com)**

