

Colt IP VPN Services

colt

smarter / faster / further



Agenda

- 
-  An introduction to IP VPN
 -  Colt IP VPN
 -  Hybrid Networking
 -  Workforce Mobility
 -  Summary

Drivers behind IP VPN adoption

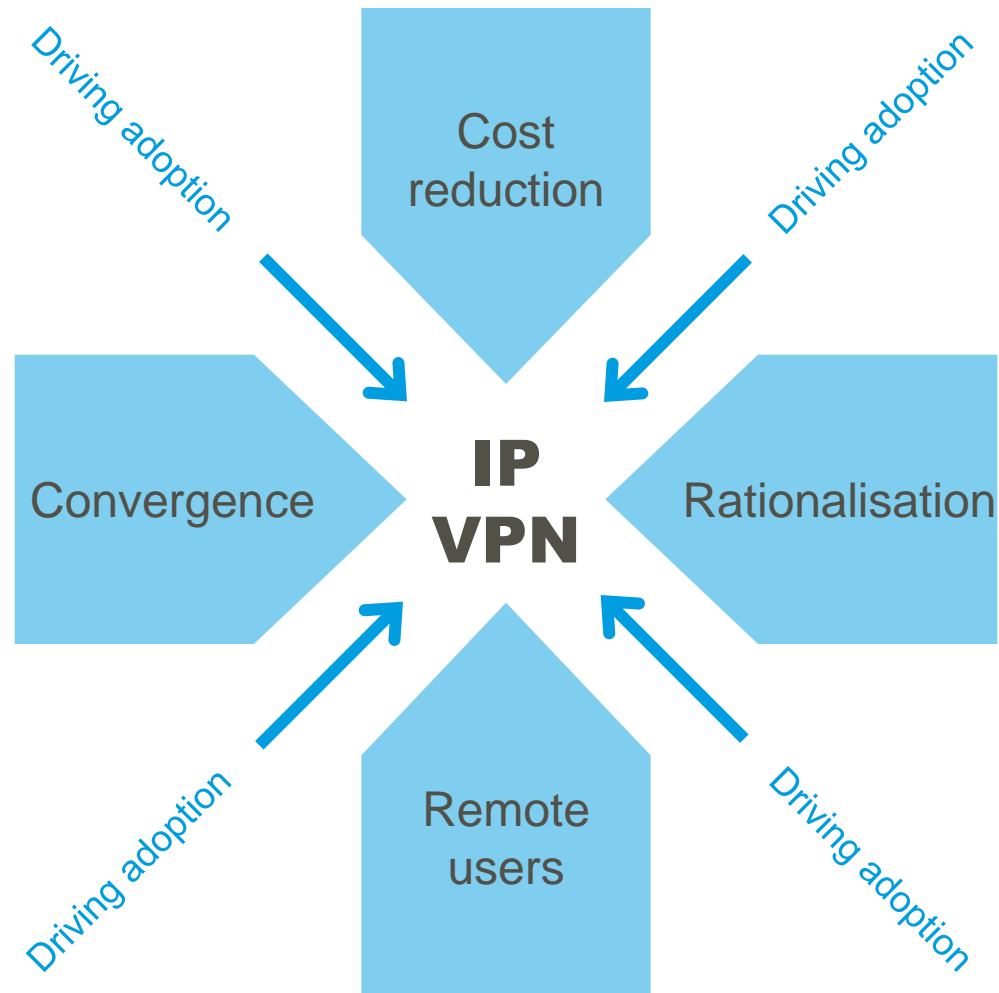

Colt IP VPN – Business value

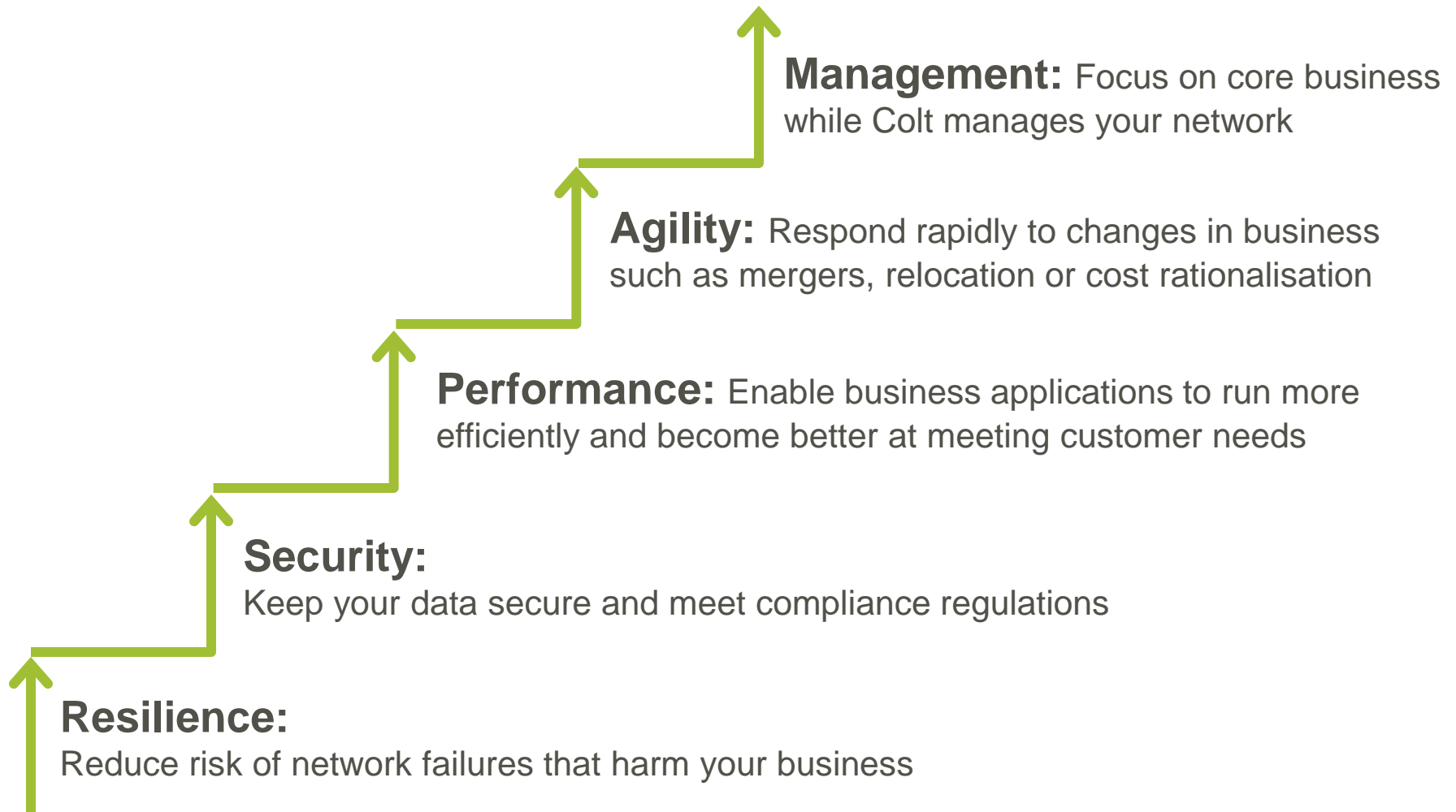

Colt IP VPN

colt

smarter / faster / further



Core technical specifications

	Colt IP VPN Plus	Colt IP VPN Access
Transport technology	MPLS	
Managed router	Yes	No
Protocols	IPv4	
Service bandwidth	64kbps to 10Gbps	
Class of Service	5	
Routing protocols	RIP, BGP, OSPF, EIGRP, Static	
Data encryption	3DES (an option if required)	
Multi VPN	Yes	No
Customer interface	Ethernet 10/100BASE-T, 1000 Base-F, 10G Base-F or wires only for Colt IP VPN Access	

Bandwidth options

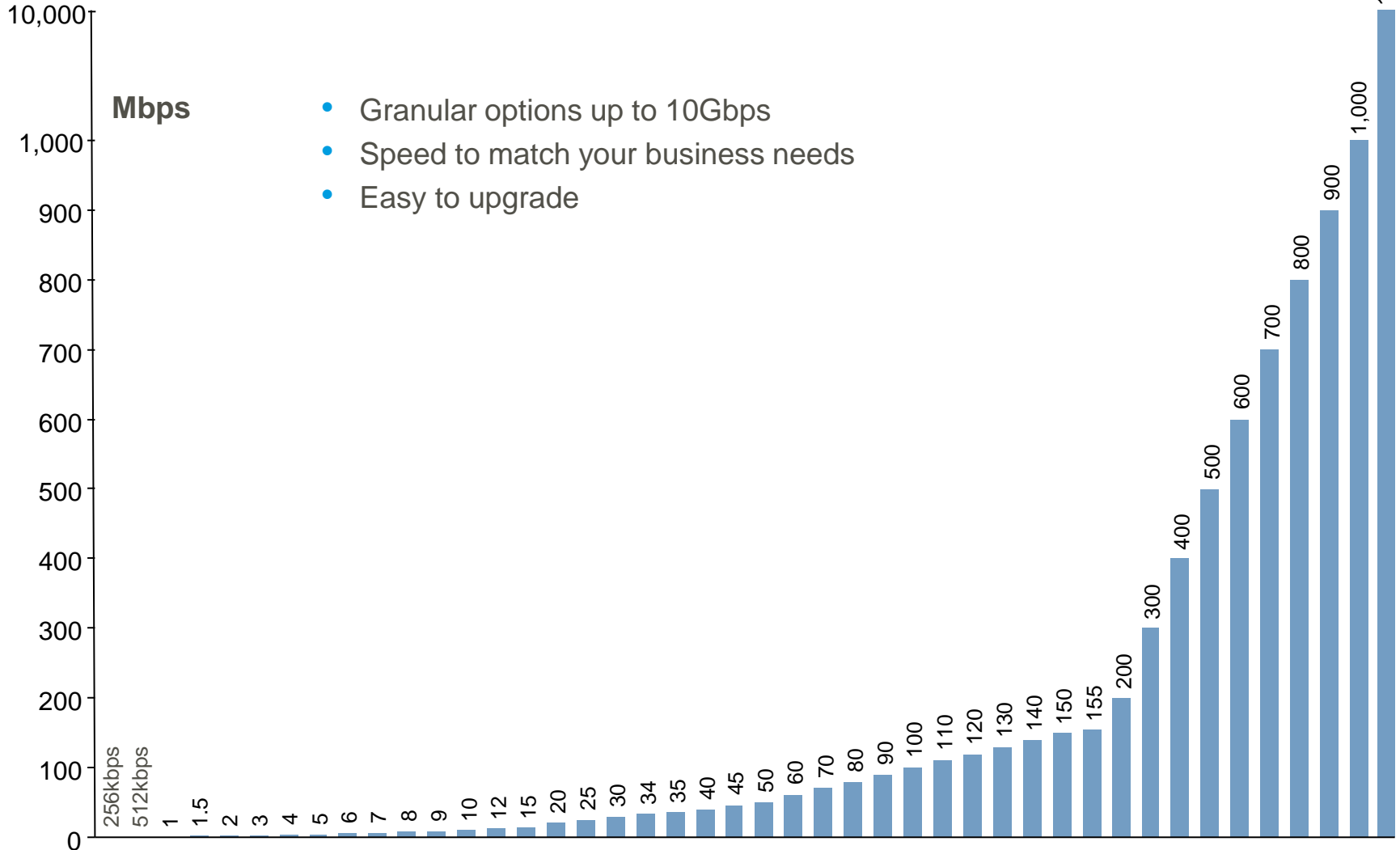

Network access

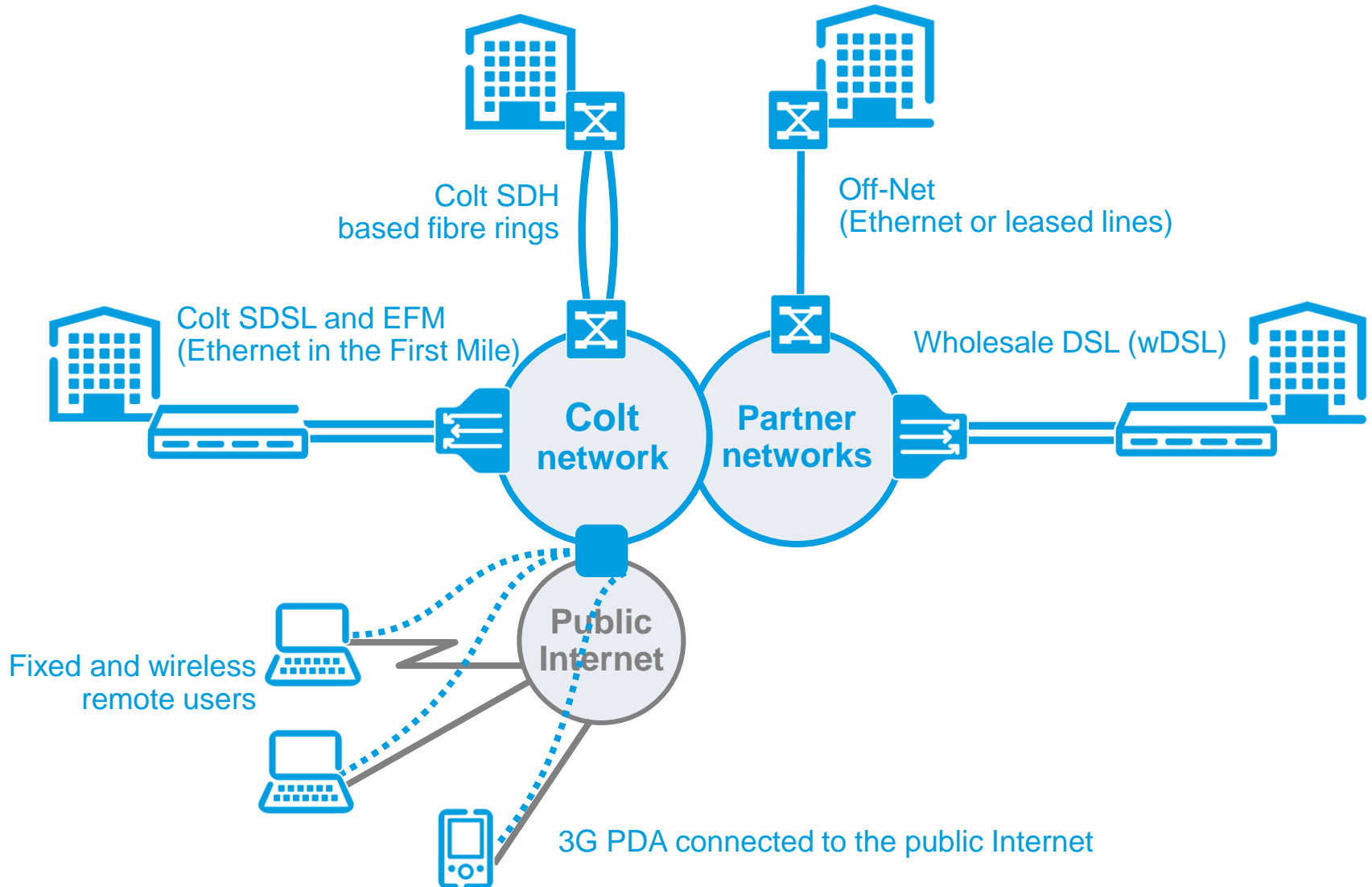

Global MPLS NNI indicative coverage

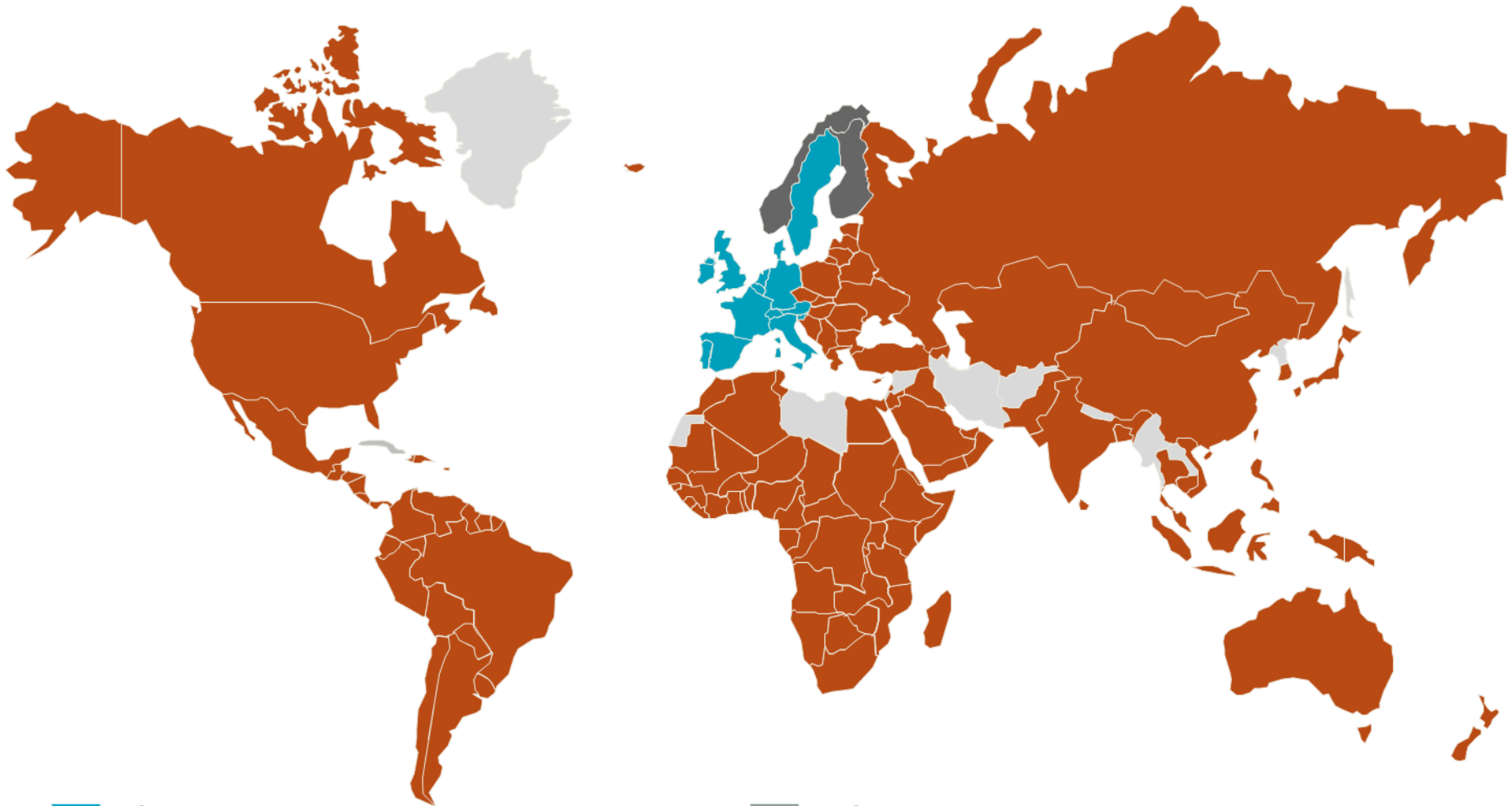

-  Colt countries
-  Coverage via Global MPLS NNI
-  Coverage via long-lining
-  Coverage on individual base

*Indicative coverage only - please check with presales connectivity

Remote fixed access

Where no commercially attractive access circuits are available, remote fixed access provides:

- Colt managed CPE router installed on any public Internet access
- Secure IPsec tunnel setup from Colt managed remote CPE to Colt network ingress point
- Includes installation, full management, peering bandwidth and service gateway

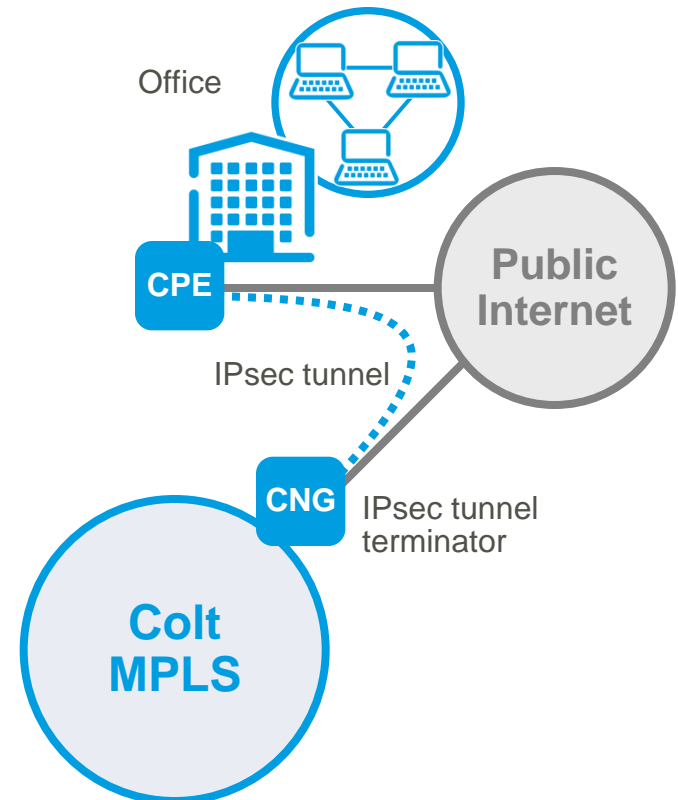

Centralised Network Gateway (CNG)

Multiservice IP infrastructure from a centralised network function

Current modules:

- Internet access
- IPsec termination
- Breakout to a dedicated or a virtual Firewall

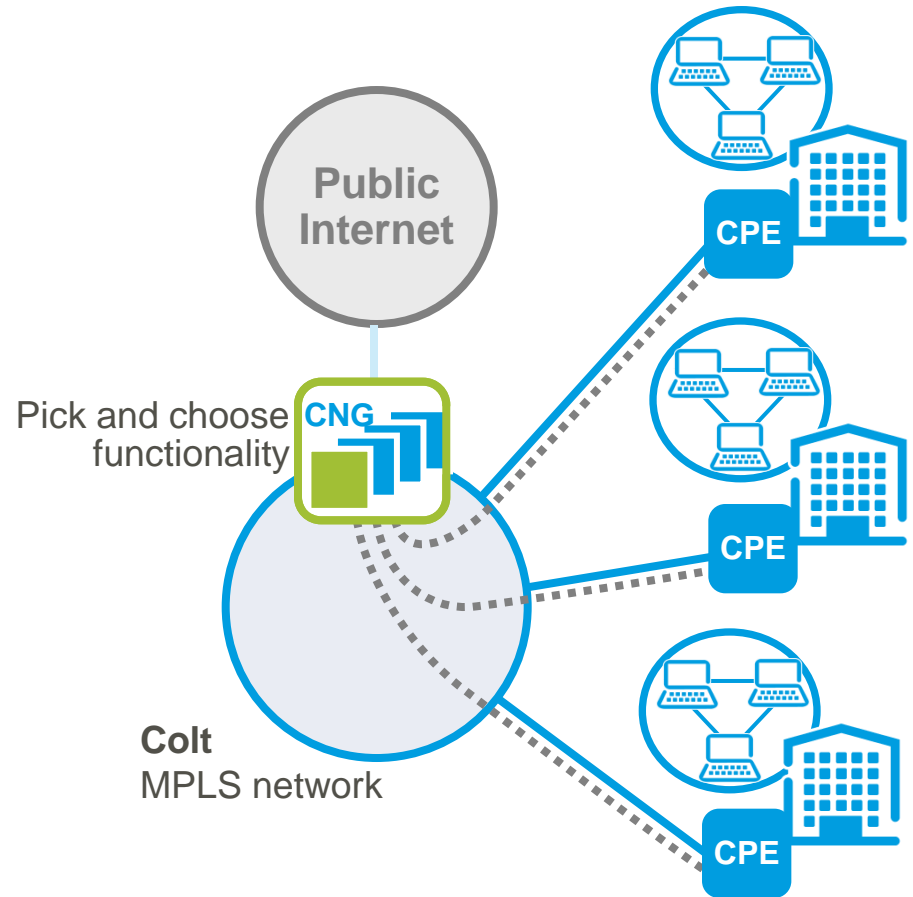

End-to-end management*

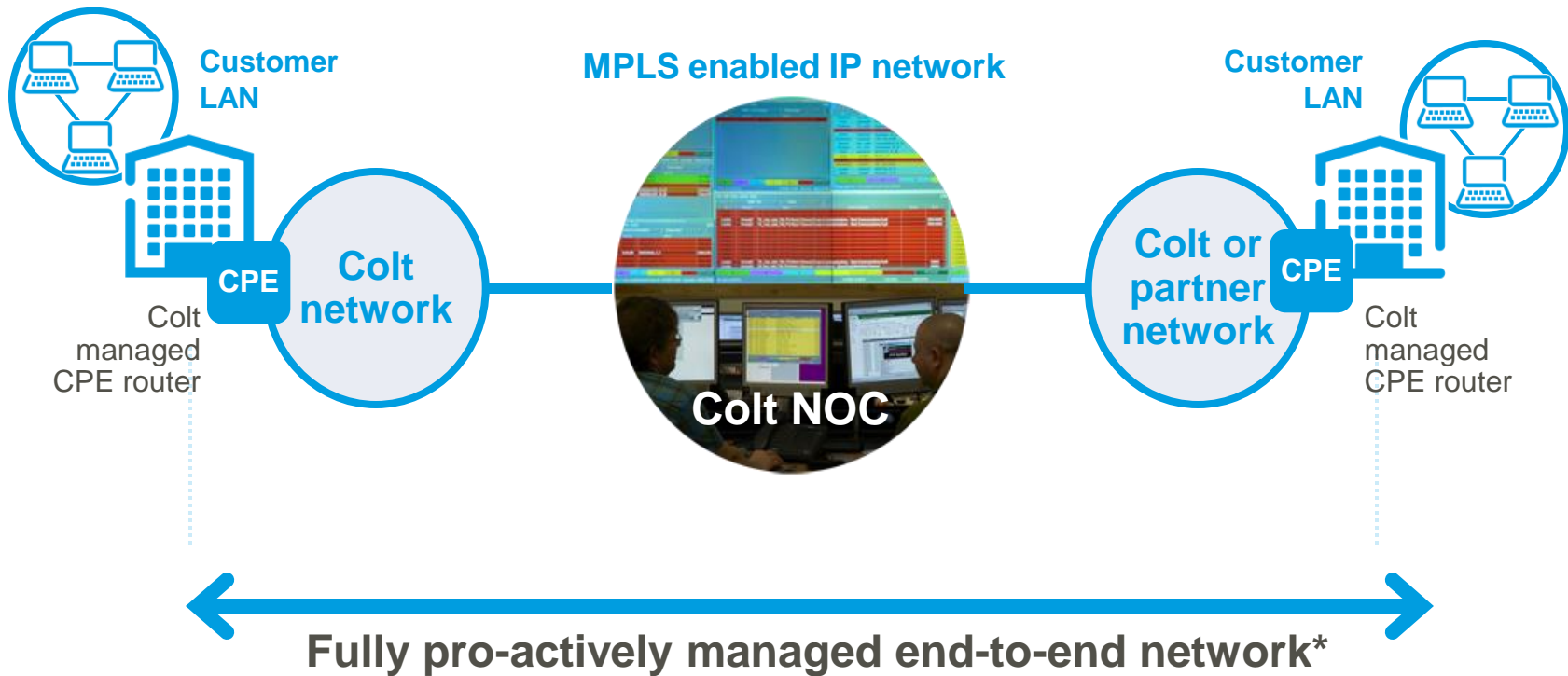

* Excludes Colt IP VPN Access which is a service without managed CPE router at your site

Security

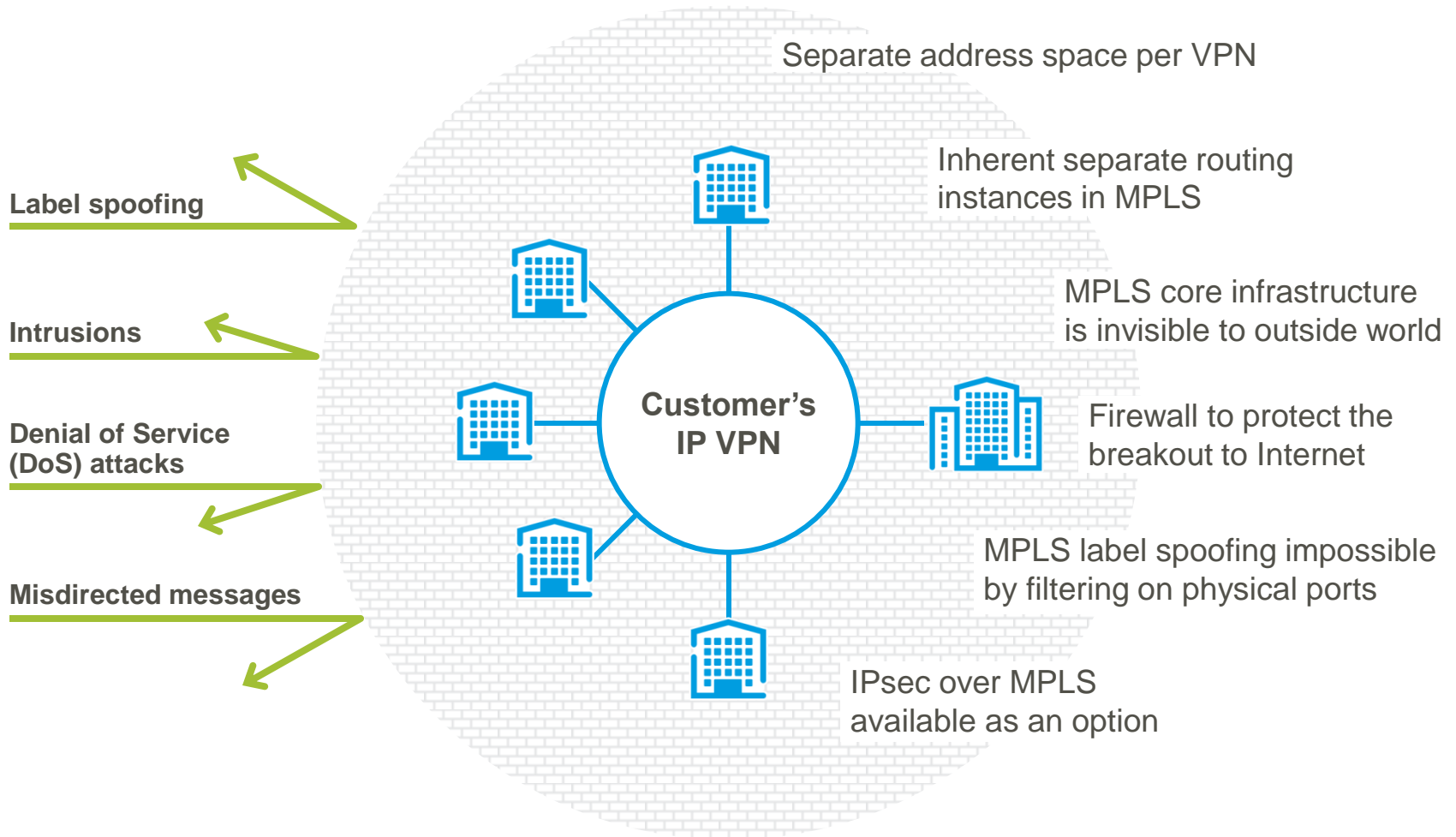

Tiered Service Level Agreements (SLA)

Service assurance	Service credits
Target Time to Repair (TTTR)	✓
Service availability	✓
Packet loss	✓
Jitter level	✓
Round trip delay	✓
Service delivery	
Target lead time for...	
Provisioning of initial network	✓
Modifications	✓

Guaranteed Quality of Service (QoS)

Enhanced availability

Dual entry

Dual fibre entry into buildings with self healing rings



ISDN backup

Fully inclusive or partially inclusive ISDN Backup Service with automatic failover



DSL backup

Additional Colt managed CPE router with automatic failover to DSL backup service



Dual access

Two Colt managed CPEs on two access circuits running a Virtual Router Redundancy Protocol (VRRP) with automatic failover



Internet backup

Additional Colt managed CPE router with automatic failover to Internet backup service



Wireless backup

3G wireless backup access to the IP VPN when the primary Colt IP VPN access circuit is disrupted



Options

	Colt IP VPN Plus	Colt IP VPN Access
Global MPLS	✓	
Class of Service	✓	✓
Application aware networking	✓*	✓*
Multi VPN	✓	
DHCP server / relay	✓	
Multicast	✓	
Ingress prioritisation	✓	
Private IP address space	✓	✓
LFI for sub 1Mbps	✓	
Network-based Internet access	✓	✓
Online reporting	✓	✓

* New feature due May 2010

Class of Service (CoS)

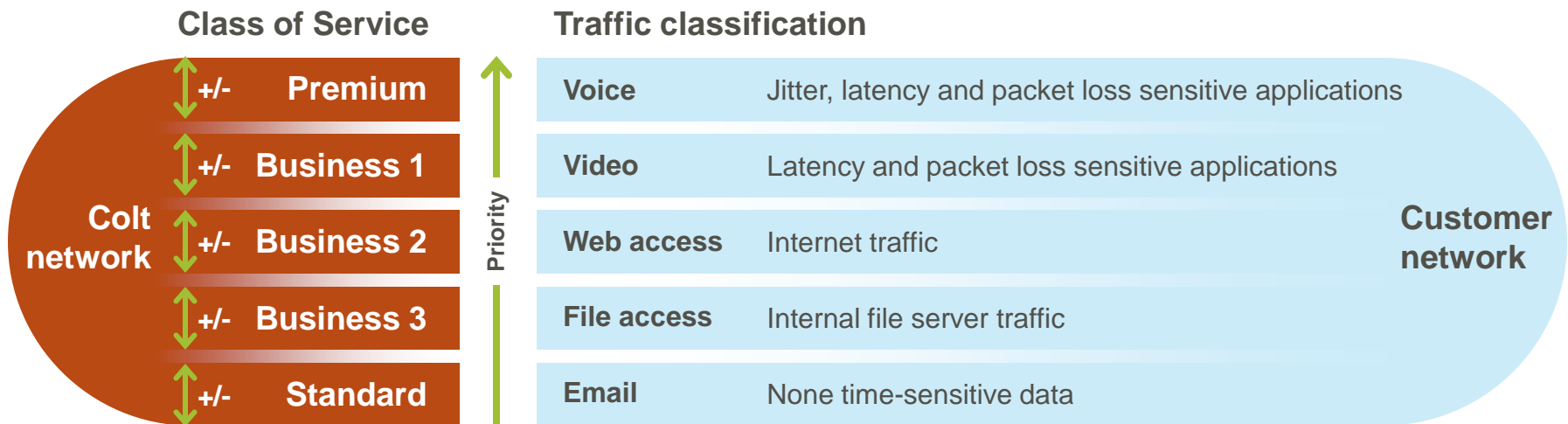
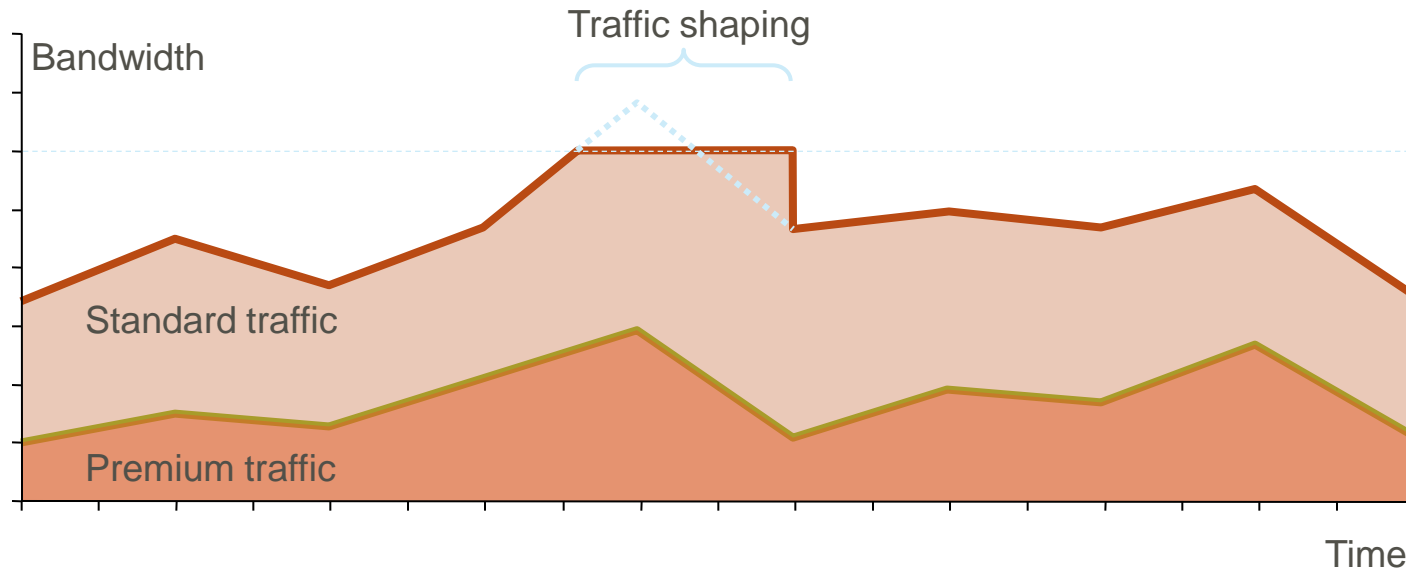

Application Aware Networking (AAN)

- Moving towards guaranteed application performance
- Visualisation of the applications running over the IP VPN
- Optimisation by applying application depending Class of Service with fine granularity
- Protocol acceleration, including TCP timer tuning
- Application reporting

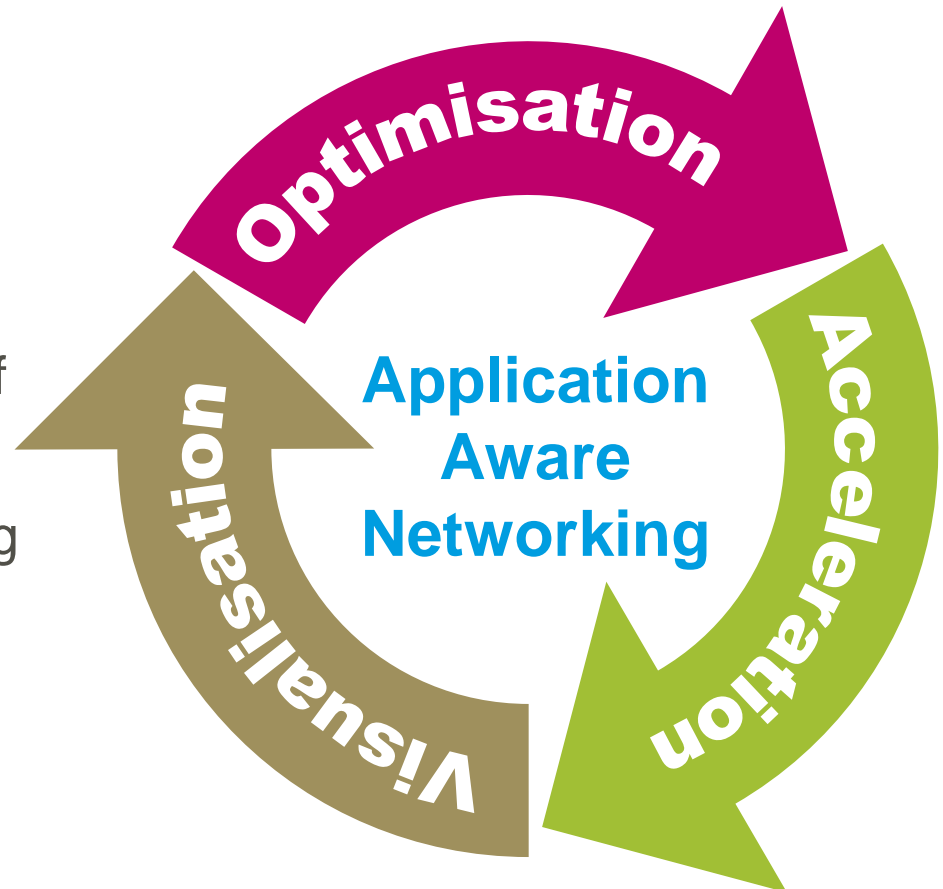

Multi VPN

Multiple extranets over the same VPN network

Implementing separate logical VPNs over one common physical VPN infrastructure. Every site can then participate or not in a logical VPN.

..... Logical circuits



Customer LAN



Colt managed CPE router

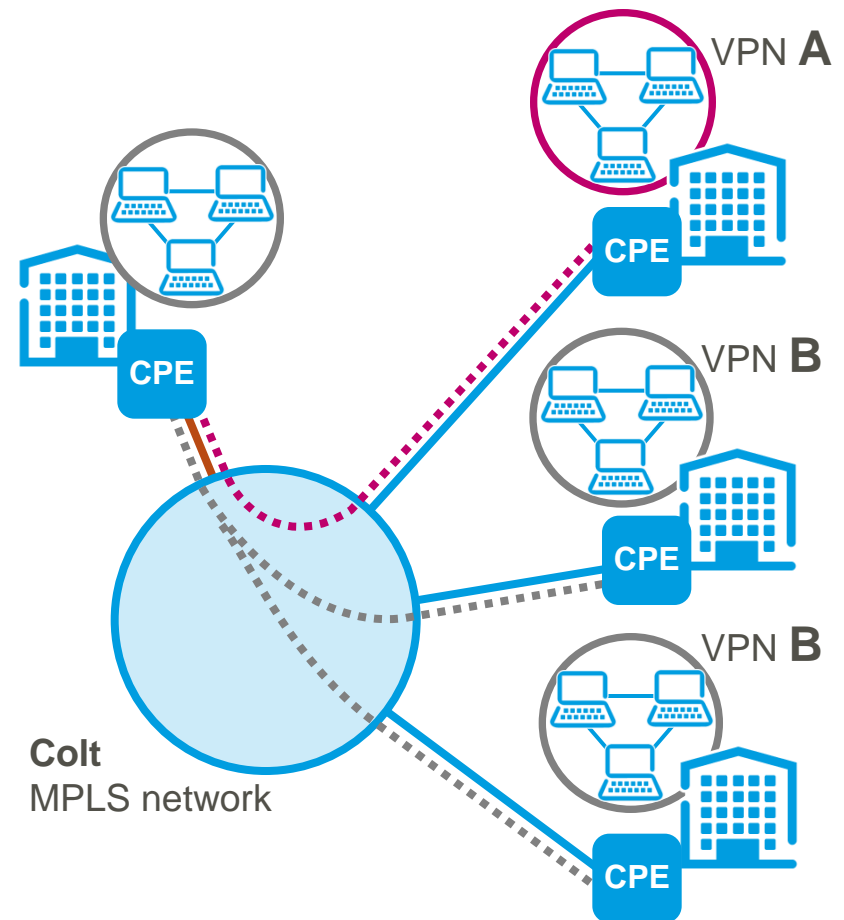

Network based Internet access

- Delivered via the Centralised Network Gateway (CNG)
- Central delivery of Internet access used by all sites connected to the IP VPN
- Available to all Colt IP VPN sites irrespective of access circuit or technology
- Support for either customer or Colt managed firewall

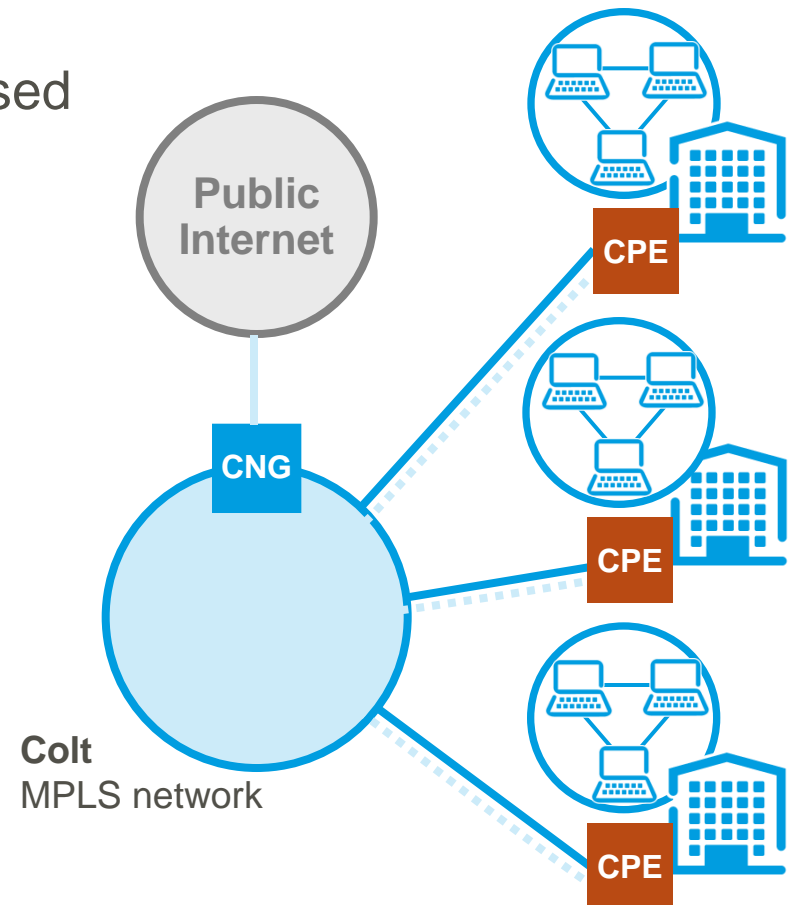

Enhanced online reporting

Silver

Throughput

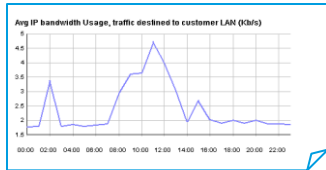

Availability

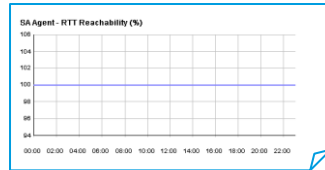

Latency

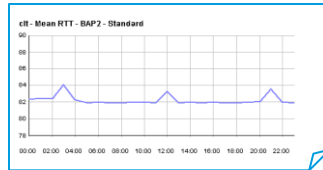

Packet loss

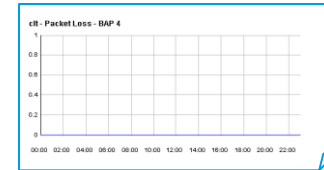

Jitter

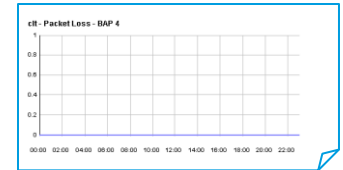

Gold

Silver +

Router configuration

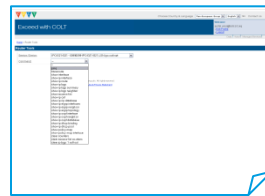

Events log

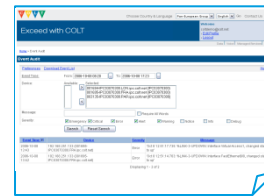

Service status

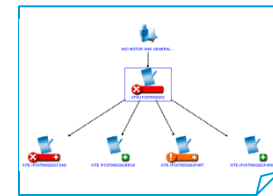

Hybrid Networking



colt

smarter / faster / further



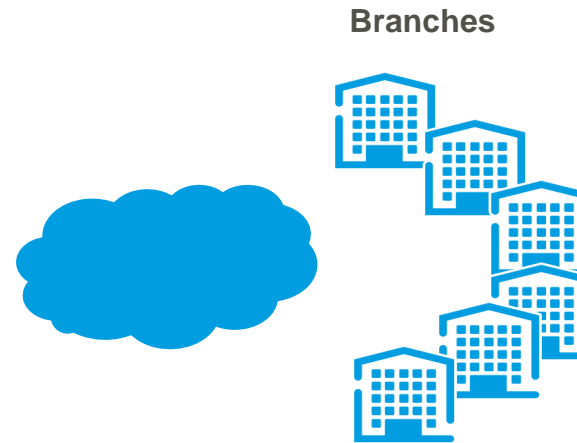
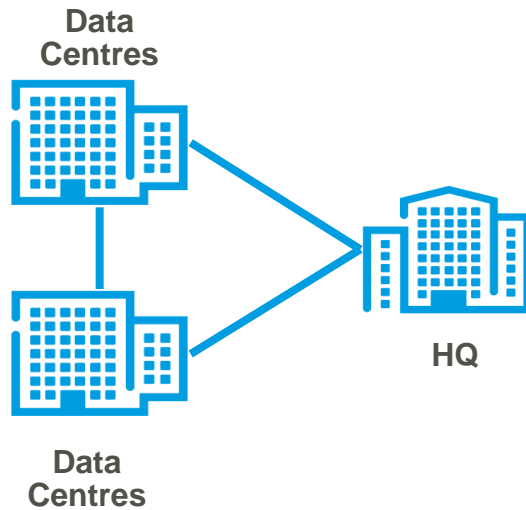

Business-critical Applications

- Business Critical Applications, e.g. ERP (SAP, Oracle), Virtual Desktop (Citrix) and Collaboration (Sharepoint)
- More and more Centralised and Virtualised
- Strong availability requirements drive the need for data replication and migration of virtual machines
- Need for a few high-speed low-latency point-to-point interconnections for traffic predictability

Business-critical Users

- Business Critical users, whose productivity is critical for the business
- Strong performance requirements to support the business, avoid discomfort among the employees about the quality experienced and reduce the complaints to the IT department
- Need for a high number of low-speed any-to-any interconnections, with control and commitment over traffic and application performance

Data WAN Evolution: Hybrid Networks

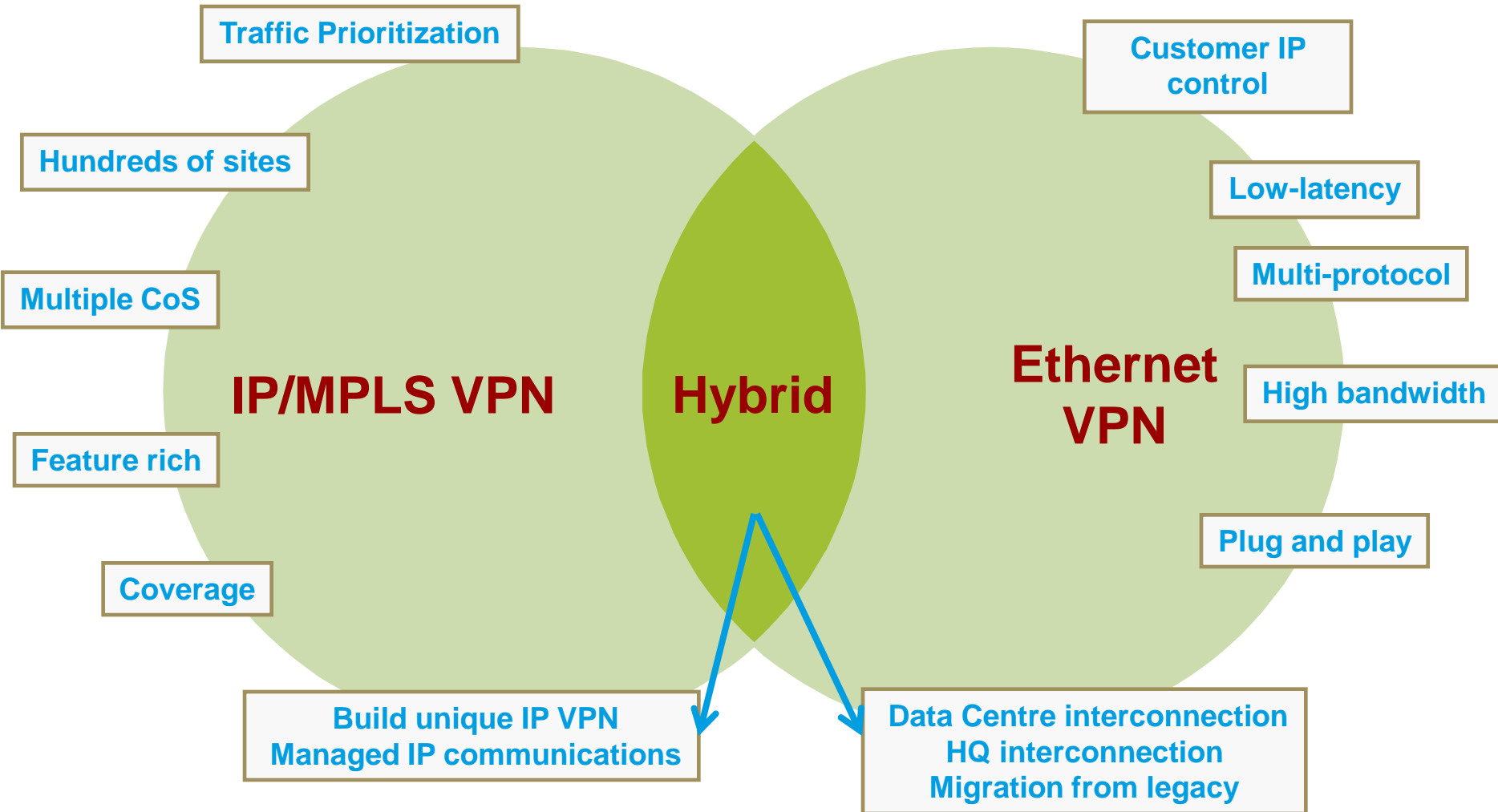

Scenario



Data Centre

HQ



Data Centre

Branches



Example:

- 1 headquarters
- 2 datacentres
- 20 branch sites

Scenario – a hard choice?

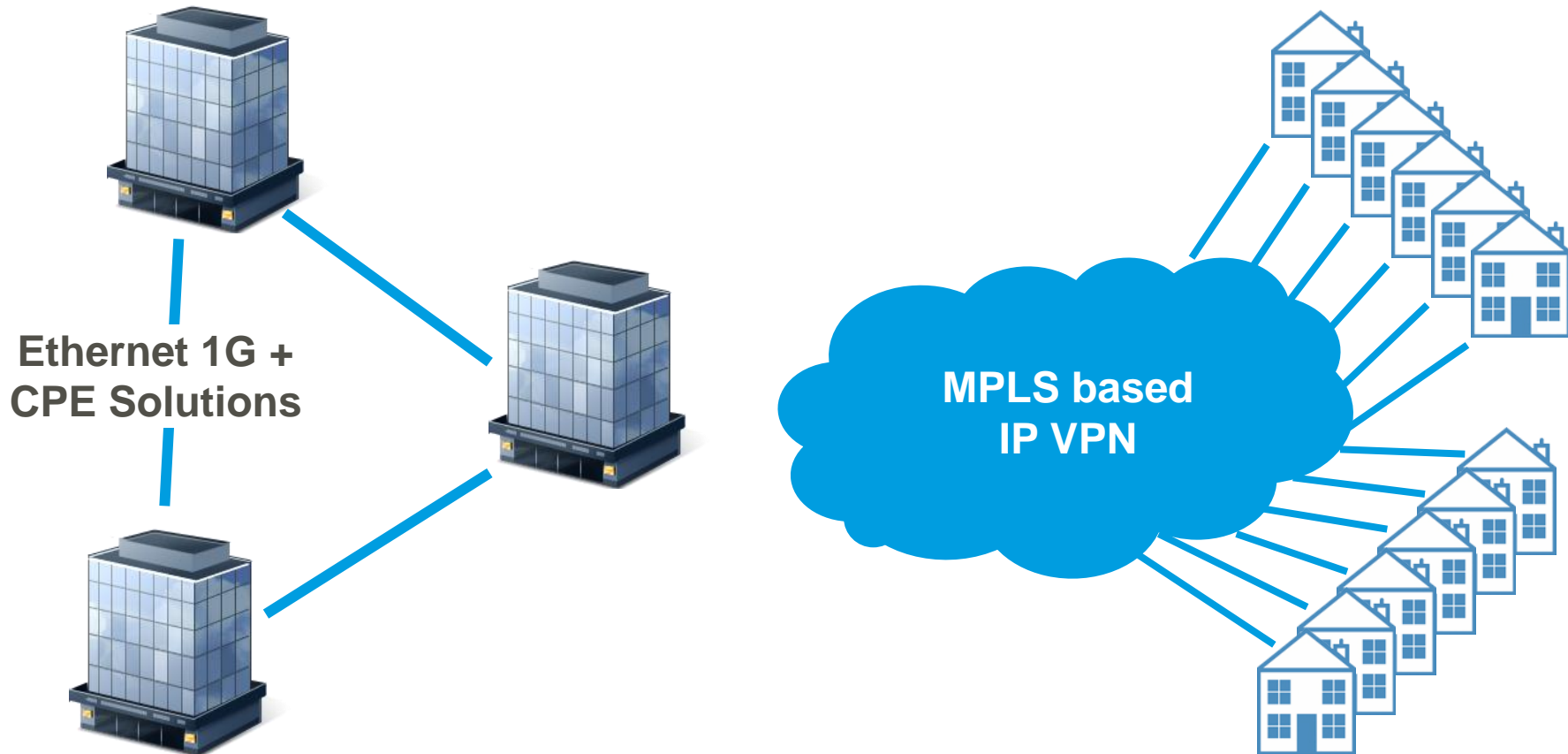

Scenario – hybrid networking

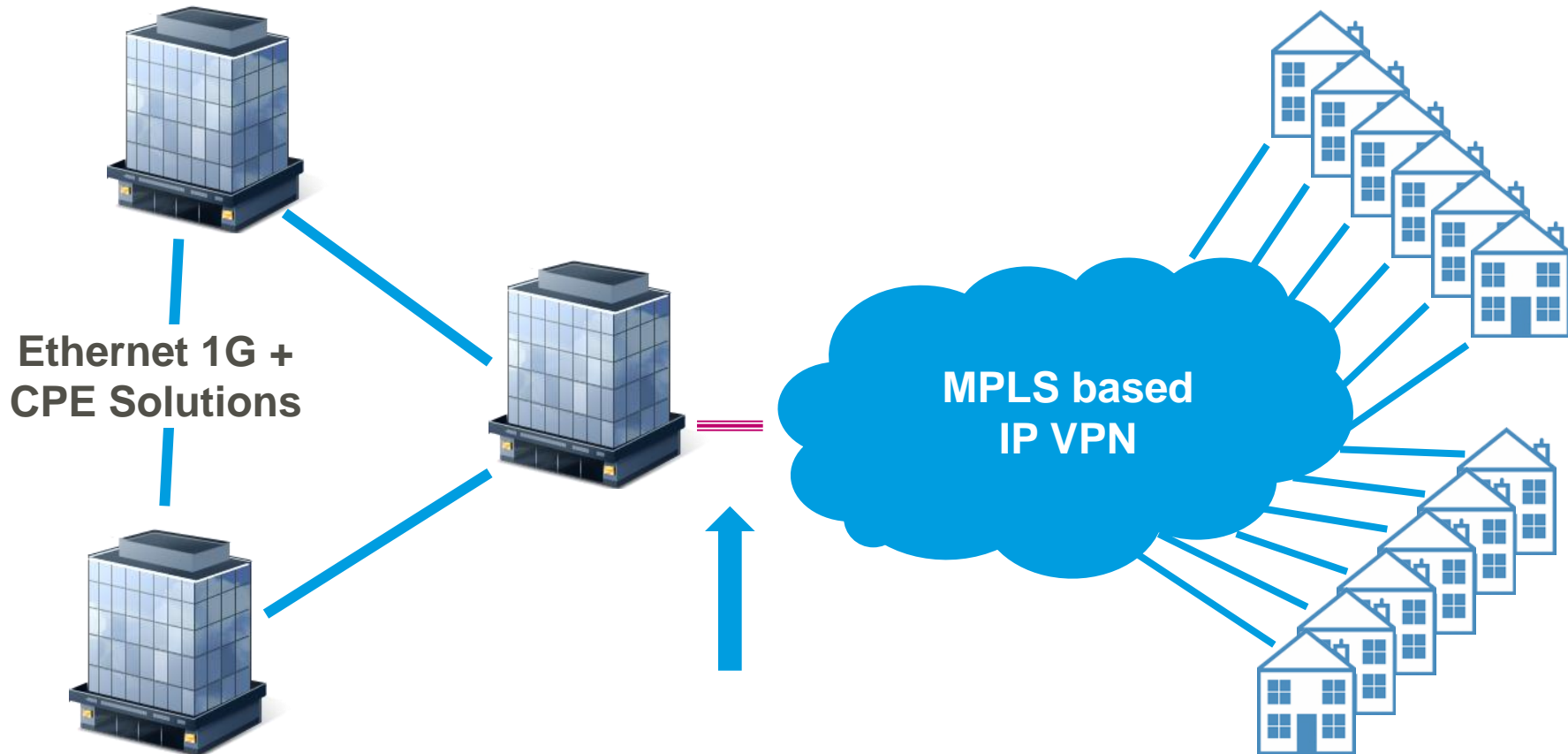

No need to make a hard choice between CPE solutions and IP VPN.

Workforce Mobility

colt

smarter / faster / further



Workforce Mobility

Workforce Mobility simplifies and manages mobile connectivity and provides:

- End-user access to the corporate network and applications from virtually anywhere via WiFi, 3G (UK only), dial-up and home
- One software application to manage all end-user remote connections
- Highly customizable service configuration (policies and integration)
- Unlimited use of global broadband on laptops and handhelds
- Secured transport of data with user authentication
- Scalable solution for enterprises with few to thousands of mobile workers
- Fully integrated with all the benefits of the Colt IP VPN portfolio
- Independence of Mobile Network Operators
- Fixed monthly charges per user/month (inclusive use of multiple devices)

Workforce Mobility - User Experience

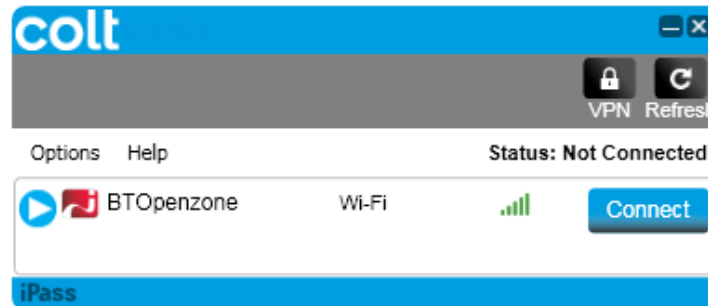

1 Start laptop with iPass client

2 Best access presented

3 Connect to Internet

4 Establish encrypted tunnel

Workforce Mobility - options overview

IP VPN Mobility (Workforce Mobility)

Options for Internet access at end-user location

by Colt using iPass (Full)

by Customer (Partial)

Bundle A

Bundle B

Encryption options

Authentication options

Access

Security

Benefits for the enterprise and users at a glance

Easy and fast to use

Higher productivity

One application for all remote access

Secured transport

Proven and Reliable

Predictable cost

Always access to corporate network

One bill

Admin Portal

Colt provides complete solution

Integration of customer 3G solution

Largest WiFi network in the world

End-user

IT department

Business

Thank you

www.Colt.net

colt
smarter / faster / further



Appendix

colt

smarter / faster / further



Colt IP VPN dual entry

- SDH self-healing rings with 50ms protection switching
- Dual fibre entry into the building

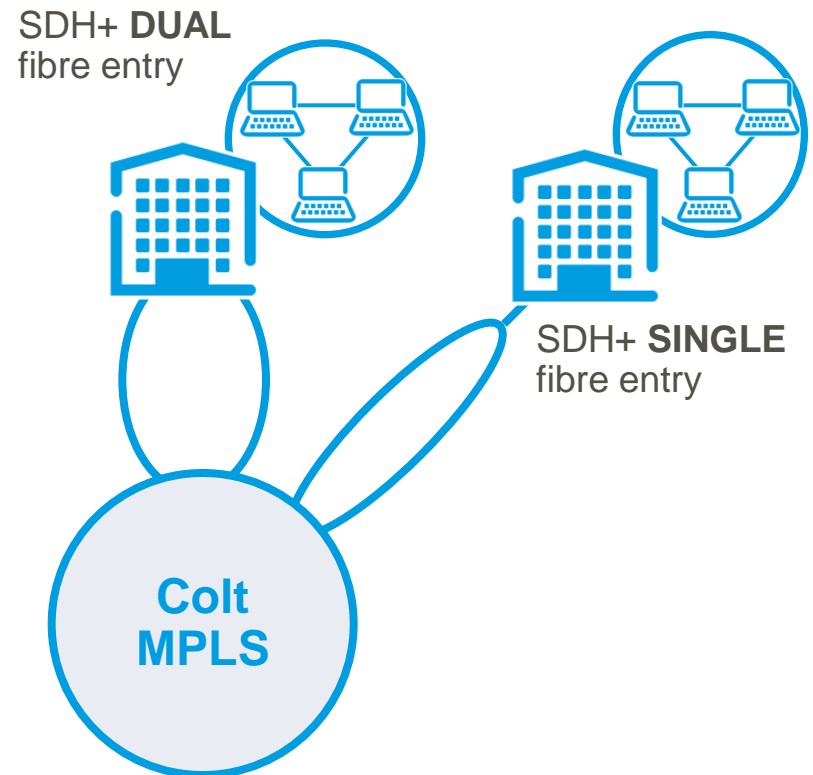

Colt IP VPN ISDN backup

- **Fully inclusive or partially inclusive ISDN backup service**
(Colt or customer has responsibility for ISDN line provision and associated charges)
- **Dial around and through the network**
- **Automatic switching between primary access line and ISDN line**
- **Support for BRI/PRIs**
(from one BRI up to four BRI and one PRI)

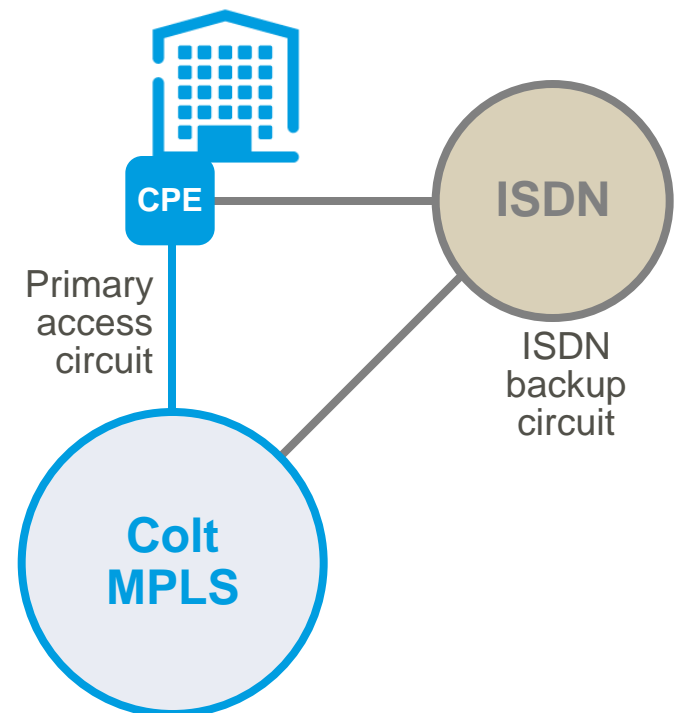

Colt IP VPN DSL backup

- Two Colt managed CPE routers provides hardware redundancy
- Automated failover to DSL if primary access circuit goes down

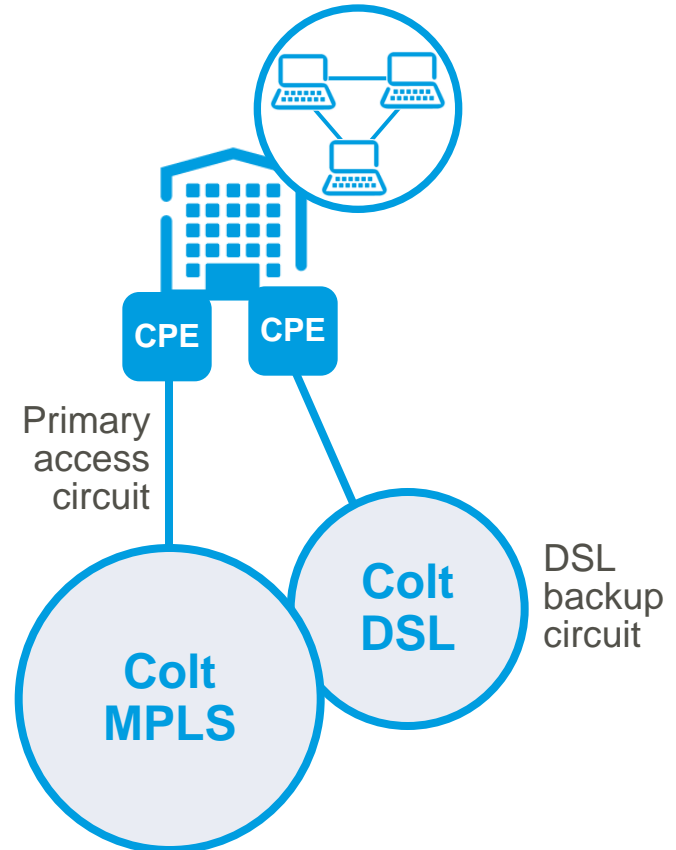

Colt IP VPN dual access

- Two Colt managed CPEs running VRRP
- Two access circuits
- Automated failover from primary to secondary circuits

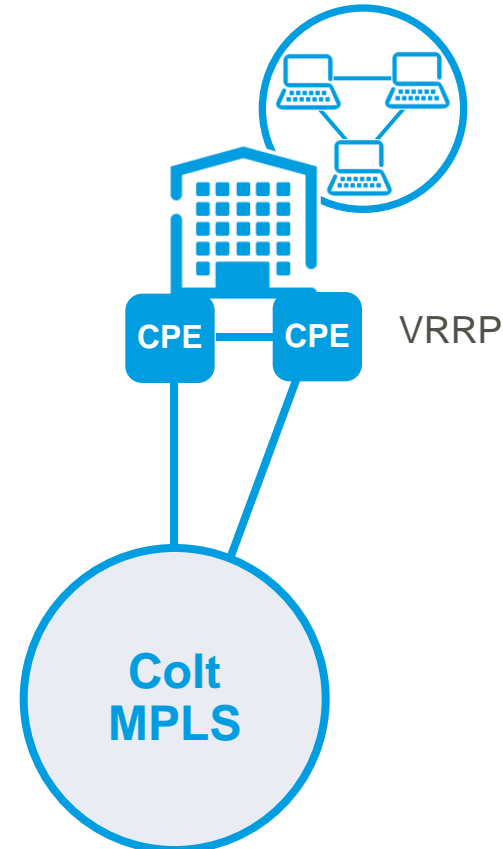

Colt IP VPN Internet backup

Resiliency outside of Colt countries, or where ISDN and DSL services are not feasible

Location of remote site	Internet access delivered by:	
Colt country	Colt	Customer
Non-Colt country	Colt	Colt

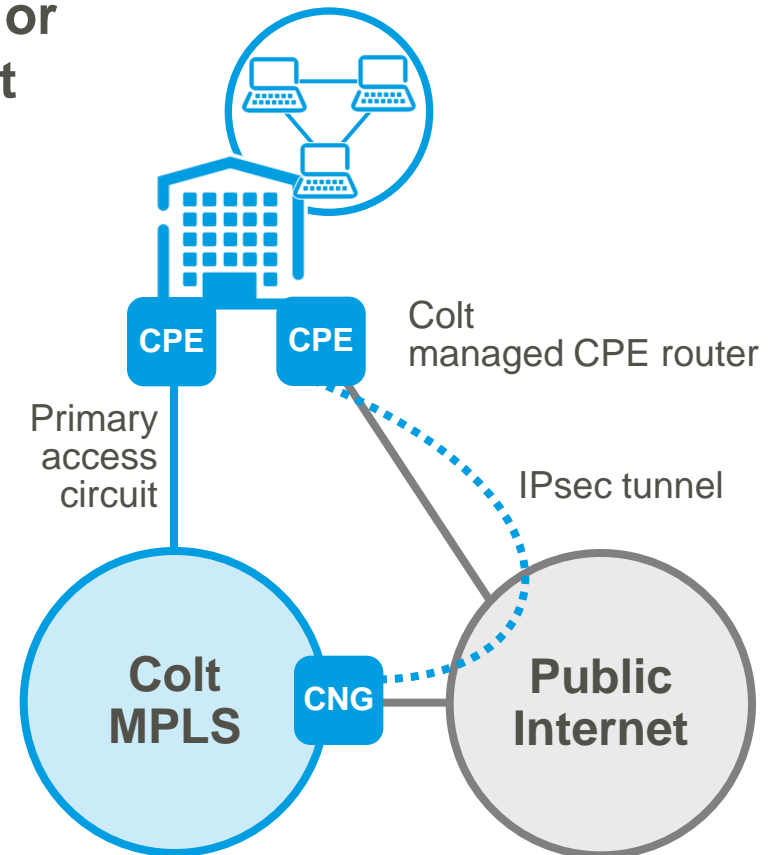

Colt IP VPN wireless backup

A truly redundant and resilient access method for standard wired services

- One box CPE solution, installed by Colt
- GPRS, EDGE, HSDPA or UMTS wireless interfaces
- Based on 3G wireless Internet (not a 3G wireless private service)
- IPsec tunnel terminated on the CNG

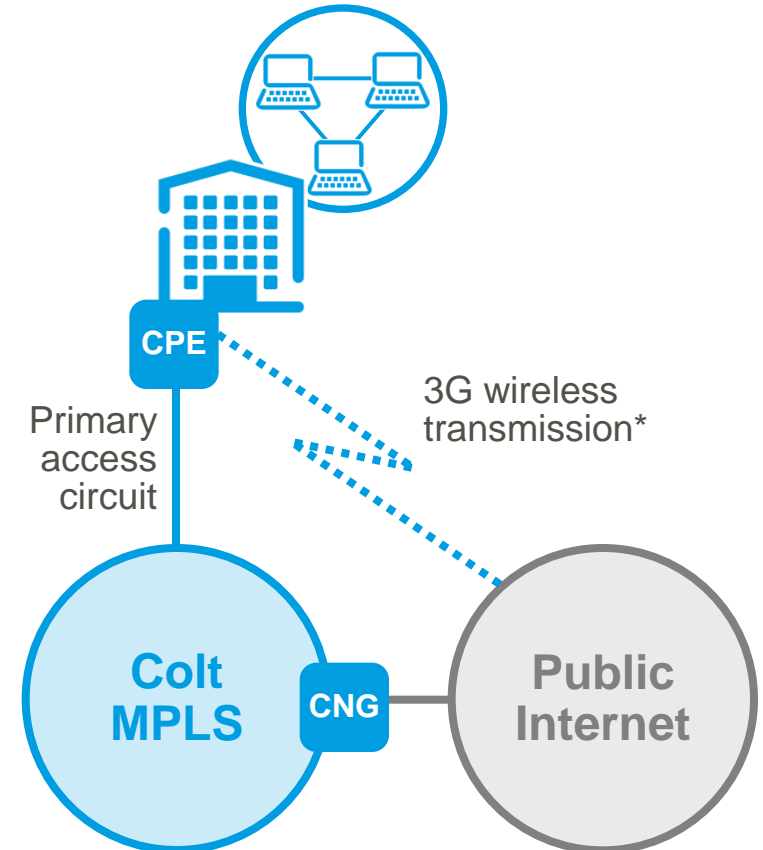

*Customer provided 3G wireless Internet service



COLT Performance Reporting Portal - Windows Internet Explorer

https://reporting.colt.net/vPortal/proxyservlet/4473-18548/0/123/showreport?&TemporalBar=true&InsId=52476&:SET:D:

COLT Performance Reporting Portal

Formats | 23:00 | 07 Oct 2007 | Hourly | over 1 | Day | Go

colt
smarter / faster / further

Instance	ifDescr
RAINBOW ALCOBENDAS(MADRID)-MAD003989	Serial1/0:0

WAN Throughput

Avg IP bandwidth Usage, traffic destined to customer LAN (Kb/s)

Hour	Usage (Kb/s)
00:00	1.7
01:00	1.7
02:00	3.4
03:00	1.7
04:00	1.8
05:00	1.7
06:00	1.7
07:00	1.8
08:00	3.0
09:00	3.6
10:00	3.6
11:00	4.7
12:00	3.5
13:00	2.0
14:00	2.7
15:00	2.0
16:00	1.9
17:00	1.9
18:00	2.0
19:00	1.9
20:00	2.0
21:00	1.8
22:00	1.8

Avg IP bandwidth Usage, traffic originated from customer LAN (Kb/s)

Hour	Usage (Kb/s)
00:00	1.8
01:00	1.9
02:00	2.4
03:00	1.8
04:00	1.9
05:00	1.8
06:00	1.9
07:00	1.9
08:00	2.6
09:00	2.7
10:00	2.7
11:00	3.3
12:00	2.5
13:00	2.7
14:00	2.1
15:00	2.4
16:00	2.1
17:00	2.0
18:00	2.1
19:00	2.0
20:00	2.1
21:00	2.0
22:00	2.0

Applet com.infovista.vistamart.report.applet.temporalbar.ReportTemporalBarApplet started

Internet 100%

Formats 23:00 07 Oct 2007 Hourly over 1 Day Go



Instance	ifDescr
	Serial1/0:0

Network Performance

SWF03010002RIC3

SA Agent - RTT Reachability (%)

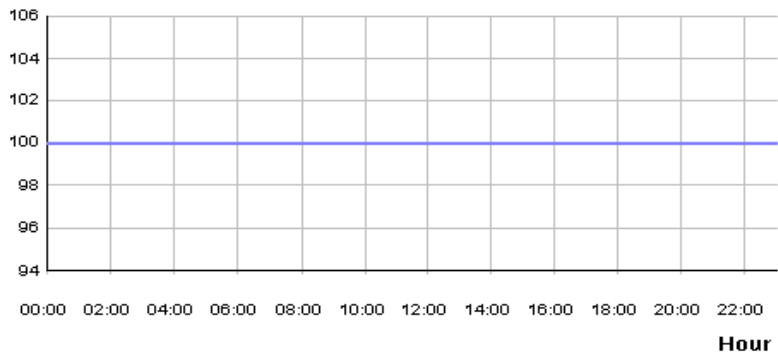

COLT Performance Reporting Portal - Windows Internet Explorer

https://reporting.colt.net/vPortal/proxyservlet/4473-18548/0/123/showreport?&TemporalBar=true&InsId=52476&:SET:D:...

COLT Performance Reporting Portal

Formats 23:00 07 Oct 2007 Hourly over 1 Day Go

Report

Instance	ifDescr
	Serial1/0:0

Network Performance
SWF03010002RIC3

clt - Mean RTT - BAP2 - Standard

Hour	Mean RTT (ms)
00:00	82.5
01:00	82.5
02:00	82.5
03:00	84.0
04:00	82.5
05:00	82.0
06:00	82.0
07:00	82.0
08:00	82.0
09:00	82.0
10:00	82.0
11:00	82.0
12:00	83.5
13:00	82.0
14:00	82.0
15:00	82.0
16:00	82.0
17:00	82.0
18:00	82.0
19:00	82.0
20:00	82.0
21:00	83.5
22:00	82.0

Applet com.infovista.vistamart.report.applet.temporalbar.ReportTemporalBarApplet started

COLT Performance Reporting Portal - Windows Internet Explorer

https://reporting.colt.net/vPortal/proxyservlet/4473-18548/0/123/showreport?&TemporalBar=true&InsId=52476&:SET:D: COLT Performance Reporting Portal

Formats 23:00 07 Oct 2007 Hourly over 1 Day Go

Report **colt**
smarter / faster / further

Instance	ifDescr
	Serial1/0:0

Network Performance

SWF03010002RIC3

clt - Packet Loss - BAP 4

Hour

Applet com.infovista.vistamart.report.applet.temporalbar.ReportTemporalBarApplet started Internet 100%

Router Tools - Microsoft Internet Explorer

File Edit View Favorites Tools Help

Address <https://portal.colt.net/routerToolsGUI/private/routerToolsExec.do?customerId=2193&service.id=2268931676>

colt
smarter / faster / further

Choose Country & Language Pan-European Group English Go Contact Us

Welcome
portal.user@testco3.org
> [Edit Profile](#)
> [Logout](#)

Data Voice Managed Services

Home > Router Tools

Router Tools

Service / Device: IPC43214321 - 00990099-IPC43214321.LON.ipc.colt.net

Command:

-
-
- ping
- traceroute
- show interface
- show ip interface
- show ip route
- show ip bgp
- show ip bgp summary
- show ip bgp neighbor
- show access-list
- show ip cef
- show ip rip database
- show ip eigrp interfaces
- show ip eigrp neighbor
- show ip eigrp topology
- show ip ospf interface
- show ip ospf neighbor
- show ip ospf database
- show ip dhcp binding
- show ip dhcp pool
- show policy-map
- show policy-map interface
- clear counters
- clear access-list counters
- clear ip bgp :1 soft out

group plc. All rights reserved.
[Use & Privacy Statement](#)

Internet

Event Audit - Microsoft Internet Explorer

File Edit View Favorites Tools Help

Back Forward Stop Home Search Favorites Media Print Mail Stop

Address: https://portal.colt.net/syslogGUI/private/syslogSearch.do?action=doSearch&orderByColumn=1&orderByOption=desc&fromDate=2006-10-08+08%3A20&toDate=2006-10-08+17%3A23 Go Links

smarter / faster / further

Choose Country & Language: Pan-European Group | English | Go | [Contact Us](#)

Exceed with COLT

Welcome
 coltdemo@colt.net
[> Edit Profile](#)
[> Logout](#)

[Data](#) | [Voice](#) | [Managed Services](#)

[Home](#) > Event Audit

Event Audit

[Preferences](#) | [Download Event List](#) | [Help](#)

Event Time: From: To:

Device: Available: Selected:

001694-IPC03070300.LON.ipc.colt.net (IPC03070300)
 001695-IPC03070300.FRA.ipc.colt.net (IPC03070300)
 003135-IPC03070300.PAR.ipc.colt.net (IPC03070300)

Message: Require All Words

Severity: Emergency Critical Error Alert Warning Notice Info Debug

Event Time <input checked="" type="checkbox"/>	Device	Severity	Message
2006-10-08 13:43	192.168.251.133 (001695-IPC03070300.FRA.ipc.colt.net)	Error	'Oct 8 12:51:17.735: %LINK-3-UPDOWN: Interface Virtual-Access1, changed state to up'
2006-10-08 13:42	192.168.251.133 (001695-IPC03070300.FRA.ipc.colt.net)	Error	'Oct 8 12:51:14.763: %LINK-3-UPDOWN: Interface FastEthernet0/0, changed state to up'

Displaying 1 - 2 of 2

Service Status View

VPN Sites: Available: Selected:

Save Selection Cancel

[View All Statuses](#) [All Notifications](#)

Customer Name	Service name	VPN Sites	
AIOI MOTOR AND GENERAL INSURANCE COMPANY OF LDT	IPC070302262	IPC070302262CGN2 IPC070302262MAD4 IPC070302262PAR7	View Status Notifications

SITE-IPC070302262BRU6
 SITE-IPC070302262CGN2
 SITE-IPC070302262MAD4
 SITE-IPC070302262MUC1
 SITE-IPC070302262MUC5
 SITE-IPC070302262PAR7
 SITE-IPC070302262PAR8
 SITE-IPC070302262OROM4

VPN-IPC070302262

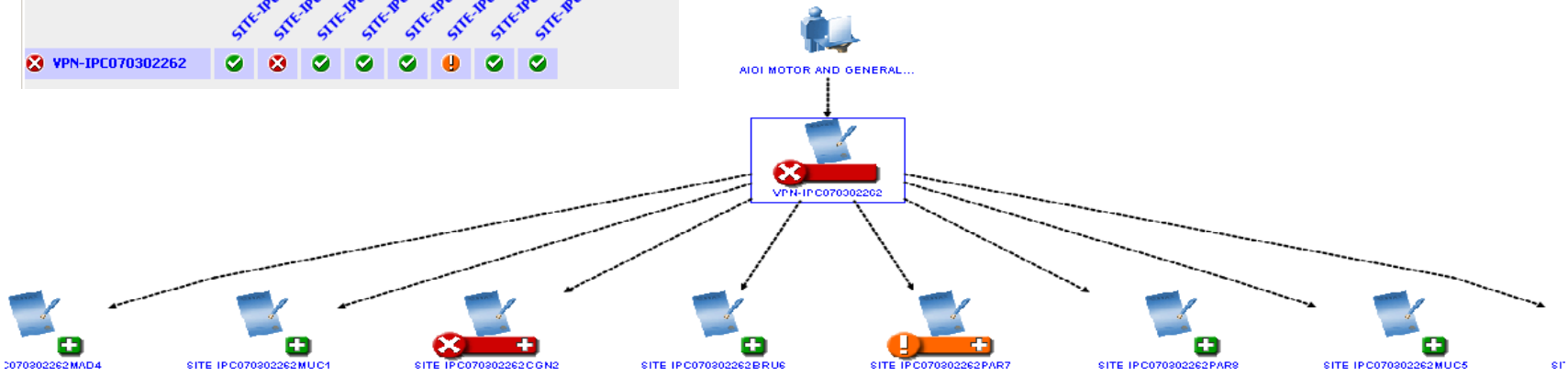

Notification Log - Test Service View IPC070302262. Manager: COLT-DEV-SAM-PRI

Sev...	Class	Event	Site	Name	Last Notify	First Notify	Last Change
!	Interface	Down	SITE-IPC070302262P...	IF-018934-IPC070302262.XBT.ipc.colt.net/...	21 May 12:1...	11 Mar 06:2...	21 May 12:20:50
!	Router	Discove...	SITE-IPC070302262C...	018713-IPC070302262.CGN.ipc.colt.net	22 May 06:0...	22 May 06:0...	22 May 06:03:24
!	Router	Discove...	SITE-IPC070302262C...	018712-IPC070302262.CGN.ipc.colt.net	22 May 06:0...	22 May 06:0...	22 May 06:03:25
!	DuplicateIP	Duplicate	SITE-IPC070302262...	10.10.2.253 [015967-IPC070302262.MUC.i...	16 May 06:0...	16 May 06:0...	21 May 11:24:44
!	DuplicateIP	Duplicate	SITE-IPC070302262...	10.10.2.252 [015966-IPC070302262.MUC.i...	16 May 06:0...	16 May 06:0...	21 May 11:24:44
X	Router	Unresp...	SITE-IPC070302262C...	018713-IPC070302262.CGN.ipc.colt.net	21 May 12:3...	21 May 12:3...	21 May 12:41:11
X	Router	Unresp...	SITE-IPC070302262C...	018712-IPC070302262.CGN.ipc.colt.net	21 May 12:3...	21 May 12:3...	21 May 12:41:11