

Antenna Installation Guide

4G Wide-Band
Omni-Directional
Marine Antenna
698-960/1710-2700 MHz

#304420



Features:

- High-Performance, Omni-Directional Antenna
- Threaded Ferrule/Post For Side Or Bottom Cable Exit
- Weather Resistant
- Built-In Ground Plane
- 20 Feet RG-58 Cable Included
- For Mobile Or Fixed Locations
- Easy Installation

Thank You For Purchasing a Wilson Electronics Antenna

Please read all instructions before installing and check the parts supplied against those listed in this guide. Wilson Electronics weatherproof antenna is omni-directional and ideal for many marine applications including small boats, cabin cruisers and yachts as well as RVs, offices and homes.

Our innovative design results in high efficiency and low signal loss, which means more signal to your cellular device. This performance-based marine antenna is backed by Wilson Electronics 30-day money-back guarantee and 2-year warranty.

Package Contents Include - 304420

- 1 - 4G Marine Antenna
- 1 - 20 foot RG-58 cable with N-Male to SMA-male connector
- 1 - Ferrule/Mounting Post for side or bottom cable exit

*Compatible with standard 1" x 14 thread Marine Mounts
Wilson Electronics Marine Mount 901119 (sold separately)*

How It Works

Wilson Electronics 4G Omni Plus Antenna will collect the cell tower signal and send it through the cable to a Signal Booster. And it works in the other direction, when the cell phone transmits, the signal is transferred to a Signal Booster and transmitted back to the cell tower.

Carefully Determine Your Mounting Location

The Wilson Electronics Marine Antenna should be mounted as high as possible with no obstructions. Marine antennas work on a "line-of-sight" basis, so the higher your antenna is, the farther it can receive a signal. This gives you a greater range for your cellular communications.

There is a compromise between installing the antenna as high as possible and keeping the cable run short to reduce signal loss. The antenna includes 20 feet of low loss cable.

If cable length over 20 feet is needed, we recommend increasing the cable size to Wilson 400 or low loss cable to reduce signal loss. Make sure your mounting location is as far away as possible from other antennas and upright objects like masts. Be careful not to kink or crush the antenna cable or bend it tightly around obstructions during installation. This can lead to poor performance and signal loss.

For assistance with your installation, contact Wilson Electronics Technical Support toll free at 866-294-1660 or visit www.weboost.com/us/support-center/

Vertical Placement

Vertical placement is very important for proper operation. There may be a desire to angle the antenna backwards for aesthetic reasons. However, not having the antenna mounted vertically decreases its performance.

A general "rule of thumb" for placement is to install all antennas at least an antenna's length away from other antennas. If there is not enough separation between antennas (especially when using a Wireless Signal Booster), then oscillation (feedback) may occur causing the Signal Booster to power down.

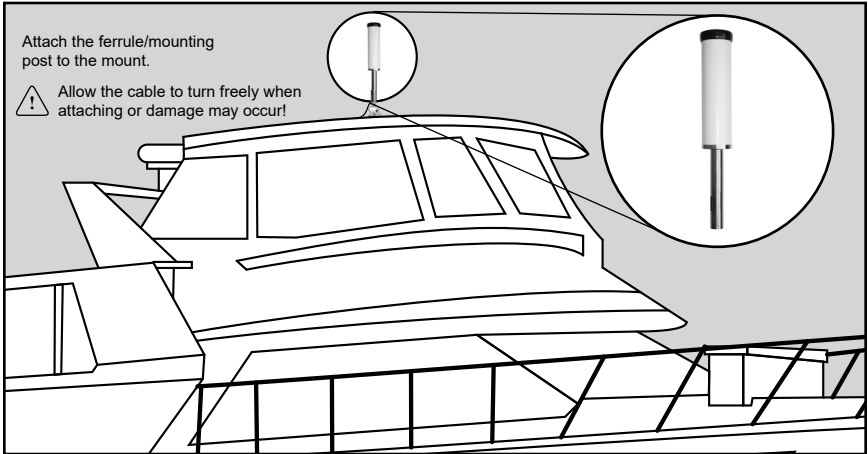

Assembling And Attaching The Antenna

Attach the N-Male end of the cable to the antenna. Thread the cable through the ferrule mounting post, with the side hole location furthest from the antenna. Attach the antenna to the top of the ferrule mounting post. Finally, attach the post to your marine mount. The SMA-Male connector will attach to your Signal Booster (Outside Antenna).

If you are using a weBoost Signal Booster, carefully follow the instructions included with the model purchased.

⚠ **RF Safety Warning:** The Outside Antenna must be installed with a separation of at least 8 inches from any persons.

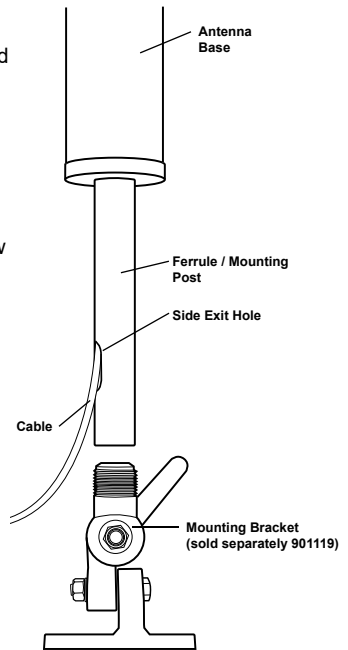

2-Year Warranty

Wilson Electronics Signal Boosters are warranted for two (2) years against defects in workmanship and/or materials. Warranty cases may be resolved by returning the product directly to the reseller with a dated proof of purchase.

Antennas may also be returned directly to the manufacturer at the consumer's expense, with a dated proof of purchase and a Returned Material Authorization (RMA) number supplied by Wilson Electronics. Wilson Electronics shall, at its option, either repair or replace the product. Wilson Electronics will pay for delivery of the repaired or replaced product back to the original consumer if located within the continental U.S.

Replacement products may include refurbished weBoost products that have been recertified to conform with product specifications.

This warranty does not apply to any antennas determined by Wilson Electronics to have been subjected to misuse, abuse, neglect, or mishandling that alters or damages physical or electronic properties.

RMA numbers may be obtained by contacting Technical Support at 866-294-1660.

Disclaimer: The information provided by Wilson Electronics, LLC is believed to be complete and accurate. However, no responsibility is assumed by Wilson Electronics, LLC for any business or personal losses arising from its use, or for any infringements of patents or other rights of third parties that may result from its use.

Copyright © 2016 Wilson Electronics, LLC. All rights reserved.

Antenna Specifications

Part Number	304420
Frequency Range	698-960/1710-2700 MHz
Gain	4 dBi
VSWR	< 1.8
Radiation Pattern	Omni-Directional
Polarization	Vertical
Horizontal Beamwidth	360 deg
Vertical Beamwidth	60 deg
Maximum Power (W)	100W
Input Impedance	50
Lightning Protection	DC Ground
Color	White
Connector Type	N-Male to SMA Male
Cable	20 feet, white RG-58
Dimensions	2.5 x 9.8" / 63 x 250 mm
Radome Material	UV Resistant PVC
Rated Wind Velocity	130 mph / 210 kph
Operating Temp	-40 to 158 deg F / -40 to 70 deg C
Humidity	100%
Mounting	Standard marine mount: 1" x 14 thread
RoHS	Compliant

Wilson Electronics, LLC
3301 East Deseret Drive, St. George, UT 84790
For additional Technical Support visit www.WilsonElectronics.com
or email at: tech@wilsonelectronics.com
Phone: 866-294-1660 Local: 435-673-5021 Fax: 435-656-2432