

Automated Box Chilling System.



Automated Box Chilling System with exhaust hood.

Concept

The Messer Automated Box Chilling system is the solution for processors who need instant, on-demand CO₂ chilling of perishables including boxed meat, poultry and seafood products, directly in their packing boxes.

Benefits

- Provides instant, on-demand chilling
- Precisely places carbon dioxide snow into packing boxes
- Automated dispensing for continuous production flow – eliminates manual scooping of pellets
- Adapts to various sized boxed products
- Flexibility – adjustable for production rates and product temperature requirements
- Simple controls and user interface
- Automated system – reduces labor costs
- Low cost and easy to install

Features

Designed and built to meet USDA requirements, the Automated Box Chilling System consists of one or multiple stainless steel snow horns, enclosed snowing area with dedicated exhaust, integrated conveyor, and control panel.

The system is designed for automated packing lines. As packing boxes are conveyed into the enclosed chilling zone, a sensor is activated and a precise amount of CO₂ snow is automatically dispensed into the box, on or around the product. The unit is a fully automated, on-demand system.

Operation

Safety is a core business of Messer, and unlike bins of dry-ice pellets, the Automated Box Chilling System is designed with an integrated exhaust system to prevent elevated CO₂ concentrations in the work place. Production overhead costs are reduced through automation, which eliminates the need to have an operator handle pellets, thereby reducing contamination risks as well.

Additionally, the ability to dispense precise amounts of CO₂ saves the processor money by eliminating inconsistencies from manual addition of pellets. The snow horns' low-velocity design facilitates precise placement of CO₂ snow, reducing losses associated with conventional box snow applicators. Built for total flexibility, the system is an automated, on-demand system for ease of use and process repeatability.

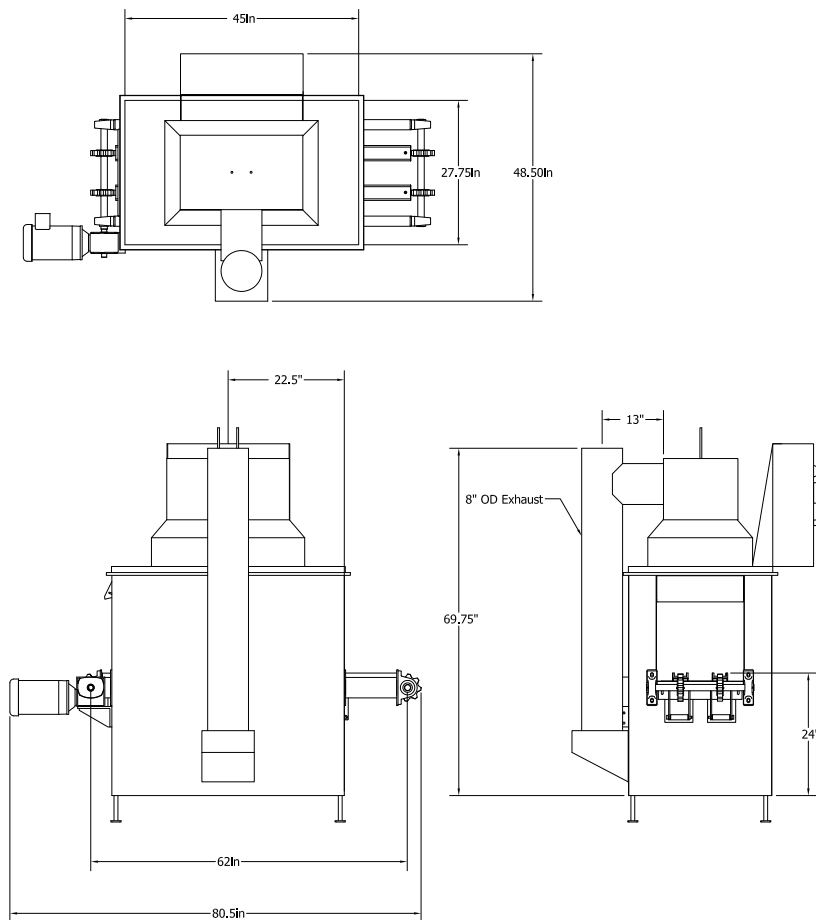

Specifications

Flow rate in liquid CO ₂ (std = 2 horns)	0.25 - 1.00 lb/sec per horn Snow time range 0.1 sec to 30 sec
Width x Length x Height	3' x 5' x 7' 6"
Instrument Air / CO ₂ Vapor (Preferred)	80 psig
Electrical	3 phase 480V/15A
Weight	650 lbs



Messer Americas
 200 Somerset Corporate Blvd
 Suite 7000
 Bridgewater, NJ 08807
 Phone: 1-800-755-9277
 sales@messer-us.com
 www.messer-us.com



Part of the Messer World