



Leaffield
Marine

Air valves for inflatable structures



THE SWITCHABLE TRANSFER VALVE

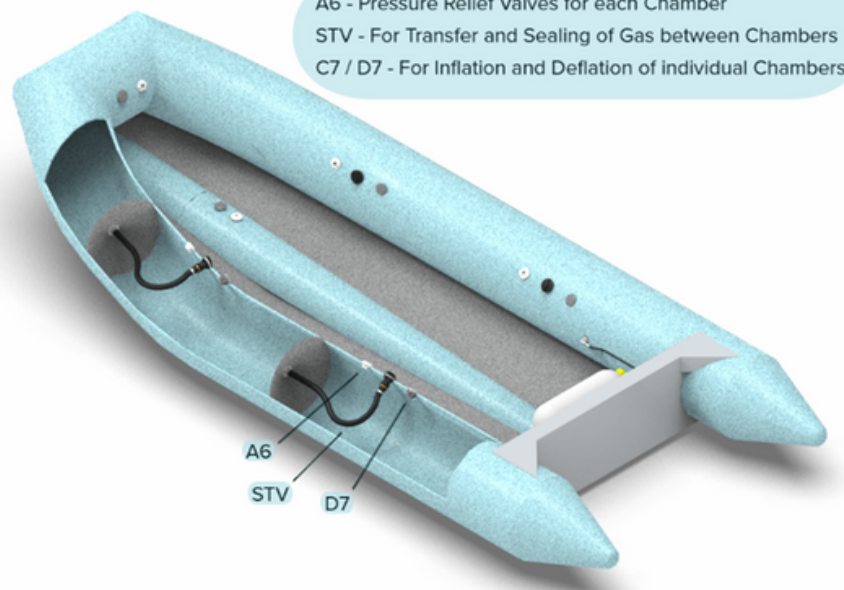

The Leaffield Switchable Transfer Valve is a patented and maintenance free valve used in many diverse scenarios ranging from military operations to leisure RIB inflation.



The valve is opened to allow air or gas to transfer between chambers of an inflatable structure with limited pressure drop, ensuring rapid inflation. Following inflation, the valves can be closed to ensure the integrity of the structure is not compromised.

The STV is also useful during deflation. If one chamber is vented to deflate the structure, the other chambers will also discharge through the same point, simplifying the deflation process and enabling the air / gas to be pumped out of a single point .

This valve allows for the fast and efficient inflation and deflation of an inflatable structure. As well as being more convenient, this can be an essential piece of equipment in an emergency or military operation as it allows for rapid deployment of a vessel.

THE SWITCHABLE TRANSFER VALVE

The patented Switchable Transfer Valve (STV), provides an internal link between adjoining chambers of an inflatable boat, providing a single point of inflation. It can be easily opened and closed to connect the chambers by rotating a control switch, fitted on the outside of the tube in a position to suit the user.

The opposite end of the STV hose locates onto the internal baffle of the boat tube, using our Snap Fit Connector.

The Valve assembly is flexible to help reduce the packed size of the deflated boat.

STV key attributes and features:

- Intercommunicating valve linking adjoining tubes or chambers.
- Provides a single point inflation for all chambers of the structure.
- A quarter turn, to switch from open to closed.
- Clear open/closed markings – visual and by touch.
- High flow between chambers during inflation and deflation – 24mm diameter aperture between chambers.

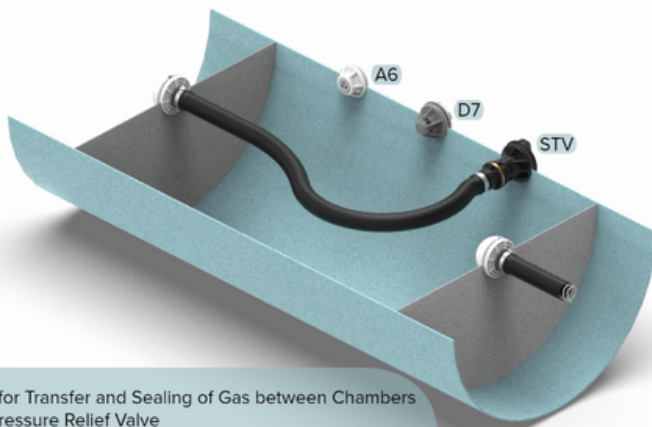

STV - for Transfer and Sealing of Gas between Chambers
A6 - Pressure Relief Valve
C7/D7 - For Inflation and Deflation of Individual Chambers

- Maintenance free
- High tolerance to debris.
- Robust and leak tight.
- Operational temperature range of -30°C to $+65^{\circ}\text{C}$.
- Clamps into fabric of chamber and internal baffle.
- Suitable for a wide range of fabrics





RIBS & INFLATABLE BOATS

Leaffield Marine valves are ideal for all RIBs and inflatable boats, from the simplest tenders to large commercial RIBS used in demanding environments.

Although our valves are used in many applications, we are known for our work with inflatable boat companies. Our valves are designed and built for high performance and reliability in a marine environment, including 100% leak testing. We design and manufacture a range of valves for fast inflation/ deflation, pressure relief and transfer. We can also offer valves to suit drop stitch flooring.

The Leaffield Marine C7 inflation/ deflation valve has become the favourite inflatable boat valve for use in demanding applications such as Military and Commercial RIBs, River Rafts and Inflatable Boats. Its stylish appearance has also won it many fans in the luxury RIB and tender market. The C7 is one of the most popular choices for all variations of RIBs and inflatable boats, as it appeals to various industries and has a strong history of support.

C7 INFLATION/ DEFLATION VALVE

The C7 inflation and deflation valve is a reliable inflation/ deflation valve used in various applications from inflatable boats to large inflatable structures. Its strong design makes it ideal for leisure RIBs and tenders. Our team have even run it over with a car without it suffering any damage.

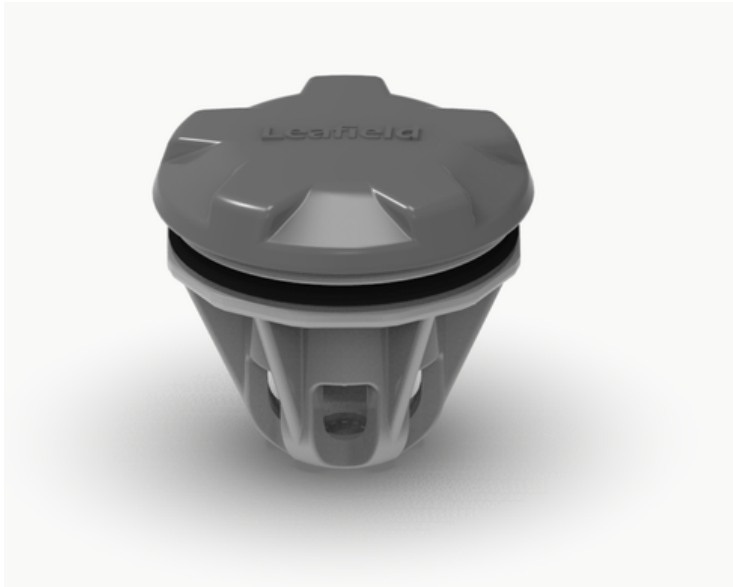

C7 Key attributes and benefits:

- Smooth, low profile
- Rugged and reliable
- 100% leak tested during production
- High quality materials to ensure long life
- Smooth profile to protect fabric when deflated

- Core can be removed from the outside of the tube for cleaning
- Available in grey or black
- Cap works as a second seal
- Caps are available in grey, black, white or yellow
- Company Brand can be added to the cap
- Smooth, snag free cap

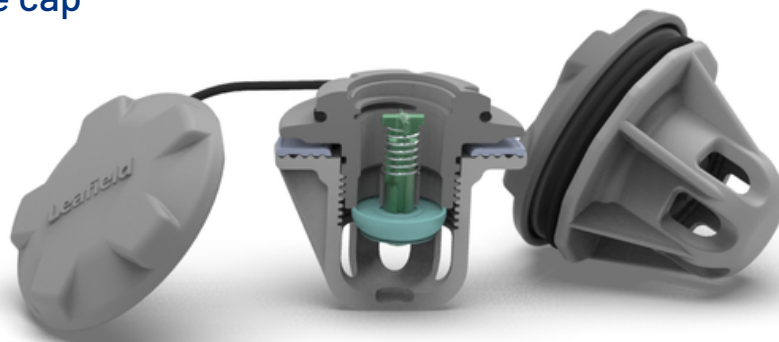
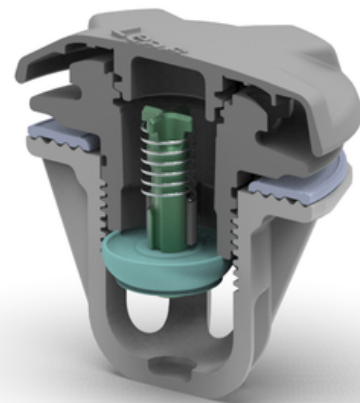



The Leaffield Marine D7 valve is designed to improve upon the highly successful C7 Valve – the favoured inflatable boat valve for use in demanding applications.



The D7 Valve has improved inflation/deflation speed compared to the C7. It has an improved clamping method, with an 'O' ring seal added to the valve core, to reduce the risk of lateral leaks in the fabric.

The D7 valve has a shorter, smoother internal profile than other valves making it ideal for smaller diameter tubes, for example – inflatable kayak floors, or small leisure tenders.

Leaffield Marine also manufacture a drop stitch compatible D7 valve fitted with an internal mesh filter. The Leaffield Marine D7 drop stitch valve is specifically designed for use with high pressure drop stitch fabric. It is ideal for paddleboards, rescue platforms, and water park equipment. It is also used in demanding Commercial and Military applications such as boats and combat crafts.

D7 INFLATION/ DEFLATION VALVE

The D7 valve is designed for use in demanding applications where a compact design is required; such as Military and Commercial RIBs, River Rafts and Inflatable Boats.

It has a shorter, smoother internal profile, making it ideal for smaller diameter tubes, for example inflatable kayak floors.



D7 Key attributes and benefits:

- High flow for size.
- Rugged and reliable.
- Low profile at 50mm overall height.
- Smooth, snag free cap.
- 'O' ring seal on the valve core to reduce the risk of lateral leaks in the fabric.

- 100% tested during production.
 - ACETAL (POM) plastic parts give high strength, chemical, ozone and shock resistance.
 - Cap works as a second seal
 - Internal cap strap.
 - Core available in grey or black.
- Caps available in grey, black, white or yellow.
- Company brand can be added to the cap, subject to a minimum quantity and tooling charge.

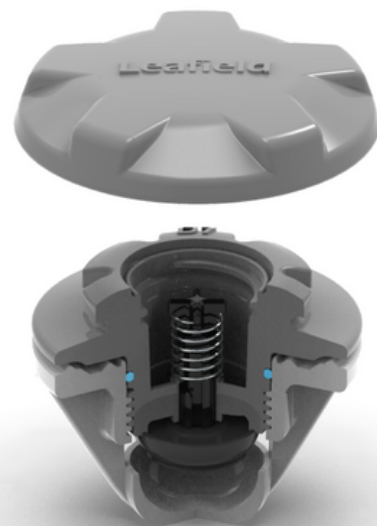

SHOULD YOU CHOOSE THE C7 OR D7 VALVE?

The Leaffield C7 inflation deflation valve offers great reliability and durability in many tough environments. It is the first-choice valve for many military and commercial rigid inflatable boats (RIBs), inflatable boats, and river rafts.



While the C7 is still a popular choice in the rigid inflatable boat market, it has now been superseded by the D7 inflation/deflation valve. The D7 retains all the advantages of its predecessor, with a few key additional features that make it more suitable in certain situations.

The D7 inflation deflation valve offers several advantages:

- **Rapid inflation/deflation:** Compared to the C7, inflation and deflation times are improved
- **Better clamping method and an O-ring seal** that decreases the chance of lateral leaks in the fabric.
- **Shorter internal profile:** The D7 has a significantly shorter internal profile. This makes it more suited to small diameter tubes.
- **Integral Mesh available for valve nut,** stops drop threads from entering the valve seal.



Both the C7 and its D7 successor are good choices for any inflatable product. While the D7 is a more up-to-date model, with some additional benefits, the C7 will never let you down. The main consideration is whether you need the added benefits of the D7.



PRESSURE RELIEF VALVES

In grueling conditions, you want to be confident that your products will maintain optimum functionality. With changes in weather and temperature, it is essential that the air pressure in your craft is stable. Leaffield Marine design and manufacture several different pressure relief valves to protect inflatable structures from over inflation caused by solar heat.

Pressure relief valves are used on a variety of different inflatable structures, from RIBs to Stand Up Paddleboards. They are an essential device to maintain the structure of a craft.

Leaffield Marine have designed various Pressure Relief Valves for different applications. However, The A6 is one of our most popular. It has become a firm favourite with many manufacturers of leisure life rafts, RIBs, and river rafts around the world. It is also ideal for any use where compact and reliable valves are critical. The pressures are accurately pre-set to your specific requirements.

A6 PRESSURE RELIEF VALVE

The A6 Pressure Relief Valve is ideal for any application. Particularly those where compactness and reliability are essential for safety.



A6 Key attributes and benefits:

- Protects the structure from over inflation and excess pressure due to solar heat.
- Approved to ISO 9650 and ISO 15738 as a transfer valve.
- Type Approval Certificate available on request
- Smooth, low profile.
- Materials have high UV resistance.
- 100% tested for opening and closing pressures.
- Rapid installation with clamp fitting.
- Operating temperature: -30°C to +65 °C.

- The valve is available in grey, black or white.
- Filter caps are available to stop debris entering the valve
- A secondary seal plug is available for test purposes (prevents pressure relief function from working)

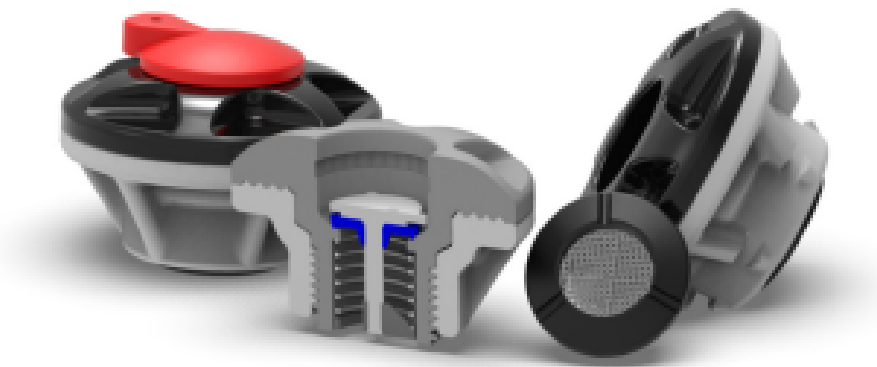
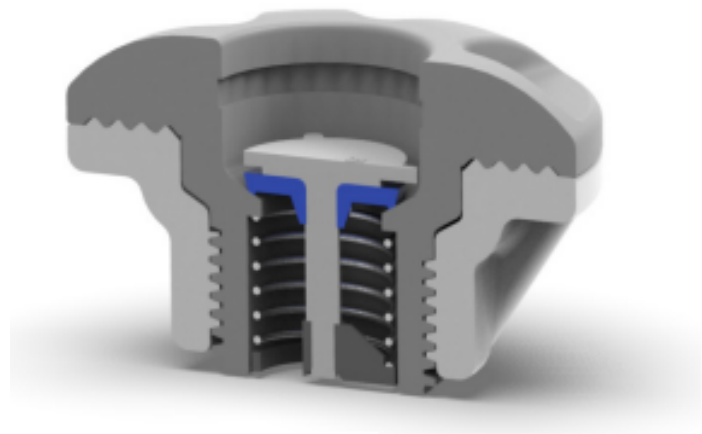

LEAFIELD MARINE'S CUSTOMISATION OPTIONS



The sleek valves from Leaffield Marine are available in several colours. The A9 and D7 cores, for example, are available in black or grey. The caps for the D7 valves are available in black, grey, yellow, red, or white. As a result, you can be assured that the valve will match your product design and maintain a sleek low-profile.

Our valve caps can be custom-made to feature company branding. We can include your logo or company name and will work with you to create a design that you're happy with. This option is subject to minimum order requirements.

If you are looking for something specific, get in touch today and we will see what we can do for you!



Leaffield Marine

Leaffield Marine is based in the UK, in the heart of the Wiltshire countryside, with in-house design and production.

We first started designing and producing valves for inflatable boats in 1965. Since then, our range of products has grown to include specialist inflation systems and air valves for many different inflatable structures, including commercial, leisure and military applications. We now supply many of the world leaders in these markets.

At Leaffield Marine, we are renowned for our engineering strength and work closely with customers in the product design phase, in order to ensure our products fully satisfy our customers' needs.

This is particularly important for many of our technical and specialist products, such as our gas inflation systems for life rafts.



We are ISO 9001:2015 registered company with many of our products are also approved to SOLAS (ISO:15738), PE(S)R and PED standards.

Leaffield Marine has been accredited with Approved Exporter Status as governed by UK HM Revenue and Customs. This opens the way for simpler trading between Leaffield Marine and countries entered into Free Trade Agreements.

WHAT OUR CUSTOMERS SAY

"I go rafting to be in the moment, so I don't want to think about my gear. Thankfully, I never have to think about my Leaffield valves."

- Member of the NRS Team

Gemini have been using the tried and tested Leaffield Valves in our commercial & professional RIBS for many years and will continue to do so.

- Gemini Marine Team

For more than 25 years, we have been Leaffield's US distributor.

Their expertise in design, manufacturing and customer service is second to none. Great support, timely deliveries and cutting edge engineering, we are proud to team up with them.

- River Gear Team

We've always been very happy with the quality of Leaffield's products for use in our oil booms. The service they offer has always been great and they consistently fulfil orders on time to meet our project requirements.

- Vikoma International Team

Leaffield Marine



To view our full product range on our website, scan the QR code below



Tel: +44 (0)1225 899550 Email: sales@leaffieldmarine.co.uk