

NOTES:

1. ASSEMBLED ALUMINUM WELDMENT CONSTRUCTION.
2. FOR USE WITH 1140 WORKLAMPS.
3. BI-DIRECTIONAL, WIDE AREA (2 X 150°) ILLUMINATION
4. (2) 1140 WORKLAMPS SUPPORTED AND CLAMPED VERTICALLY IN OPPOSING DIRECTIONS.
5. FRAME SUPPLIED WITH (4) SWIVEL CASTERS WITH BRAKES.

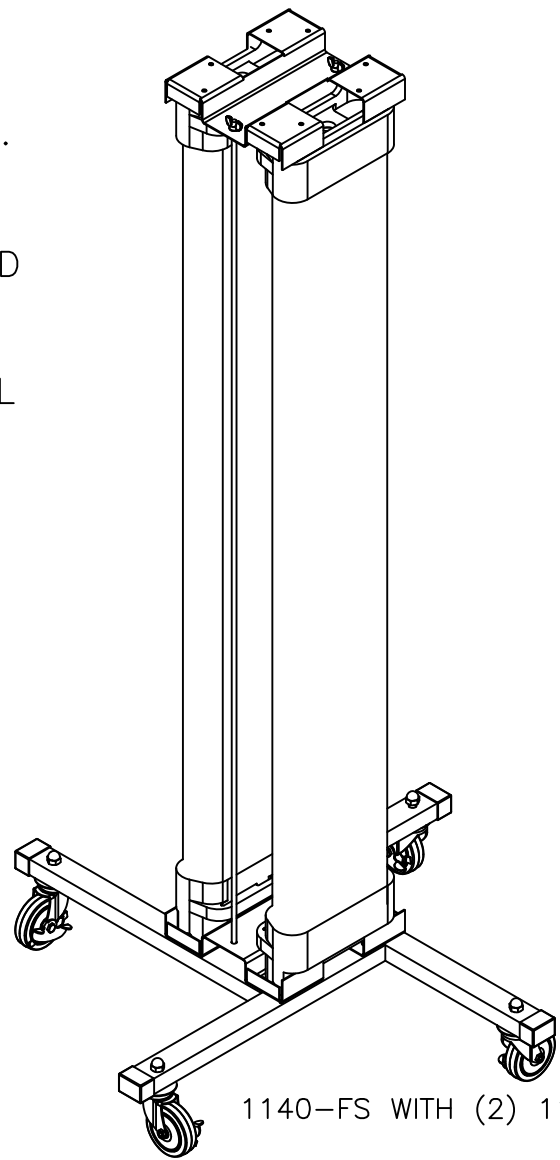

1140-FS WITH (2) 1140s

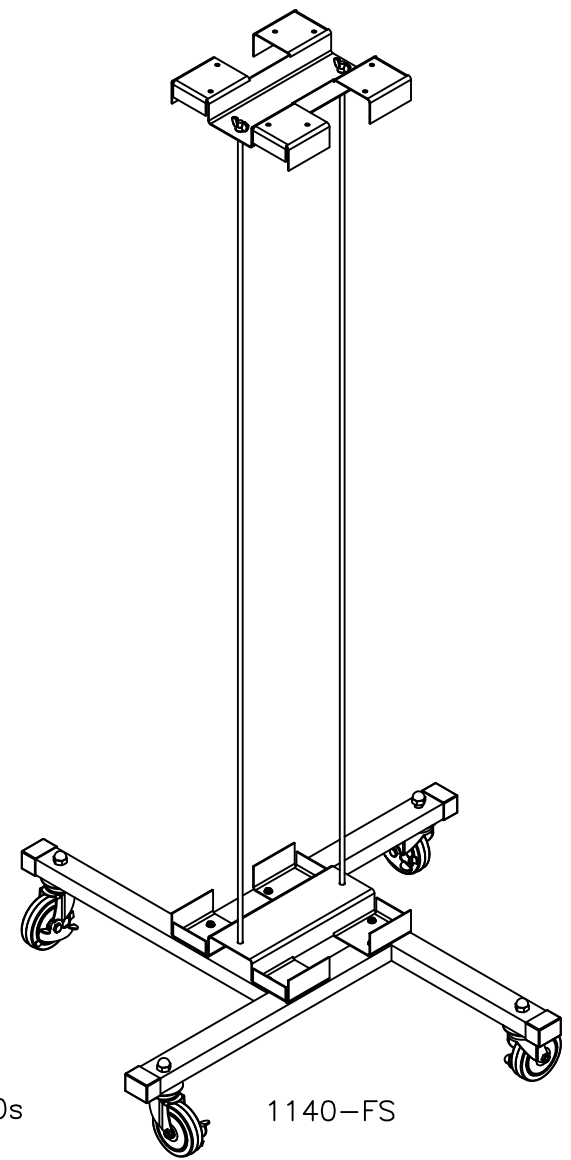

1140-FS

REV	REVISION DESCRIPTION	DATE	BY	CHKD	ECN NO.
A	INITIAL DESIGN				

**TOLERANCES**  
 FRAC. ± 1/64  
 .X ± .015  
 .XX ± .010  
 .XXX ± .005  
 ANGLES ± 1°  
 UNLESS OTHERWISE SPECIFIED  
 DO NOT SCALE  
 B SIZE

DWG. APPROVALS	DATE	REV.

DRAWN RWH      5/21/20  
 CHK'D \_\_\_\_\_



**ERICSON**  
 SAFETY IS OUR STANDARD

ERICSON MANUFACTURING COMPANY  
 1-800-ERICSON • www.ericson.com

DWG. TITLE		
WORKLAMP ACCESSORIES 1140-FS FLOOR STAND FOR (2) 1140 WORKLAMPS		
SCALE NTS	PROJ. NO. --/--	SHEET 1 OF 1
DWG. UNIT NO. 1140-FS		REV A