

NOTES:

1. ASSEMBLED ALUMINUM WELDMENT CONSTRUCTION.
2. FOR USE WITH 1140 AND 1239 WORKLAMPS.
3. ADJUSTABLE ANGLE, FLOOR LEVEL ILLUMINATION.
4. LAMP MECHANICALLY ATTACHED AT EACH END THROUGH SUPPORTING STRAP SLOTS.

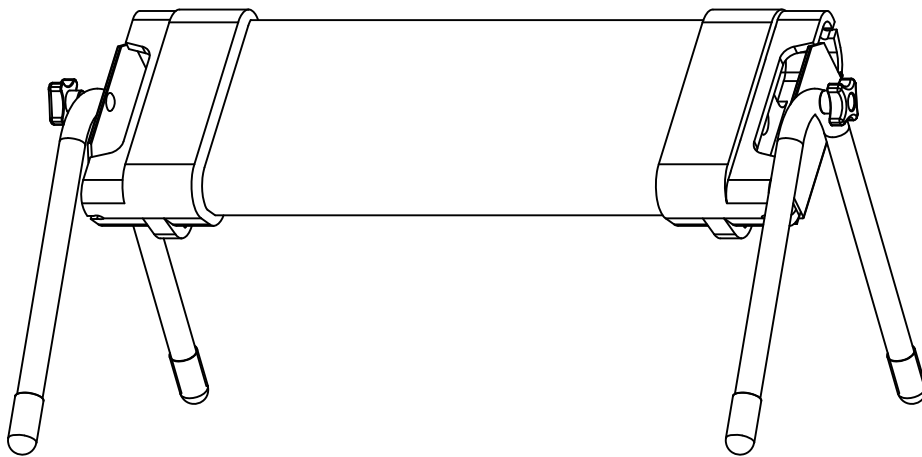

FS-PIVOT WITH 1239

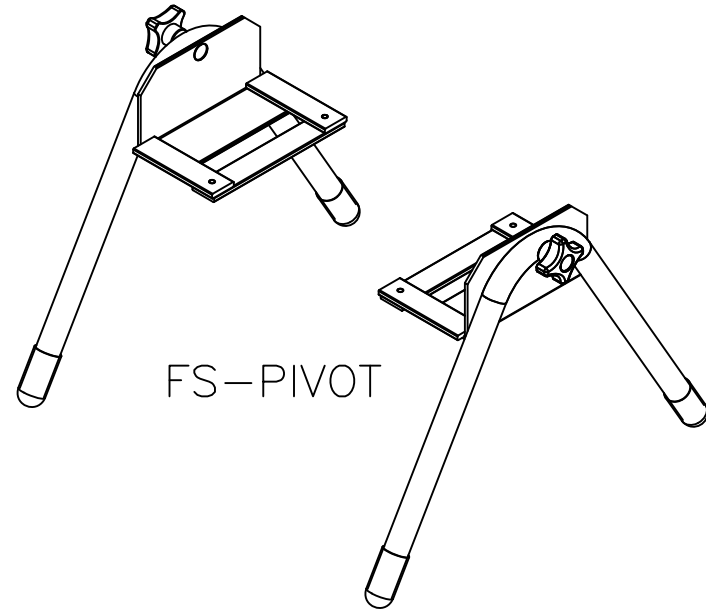

FS-PIVOT

REV	REVISION DESCRIPTION	DATE	BY	CHKD	ECN NO.
A	INITIAL DESIGN				

TOLERANCES
FRAC. ± 1/64
.X ± .015
.XX ± .010
.XXX ± .005
ANGLES ± 1°
UNLESS OTHERWISE SPECIFIED
DO NOT SCALE
B SIZE

DWG. APPROVALS	DATE	REV.

DRAWN RWH 5/21/20
 CHK'D _____



ERICSON
 SAFETY IS OUR STANDARD

ERICSON MANUFACTURING COMPANY
 1-800-ERICSON • www.ericson.com

DWG. TITLE		
WORKLAMP ACCESSORIES		
FS-PIVOT FLOOR STAND		
FOR 1140 AND 1239 WORKLAMPS		
SCALE NTS	PROJ NO. --/--	SHEET 1 OF 1
DWG. UNIT NO.		REV
FS-PIVOT		A