

SWITCH SCHEMATIC

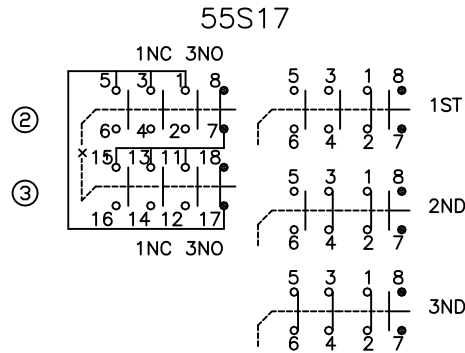

SWITCH ASSEMBLY VIEWED FROM BACK SIDE

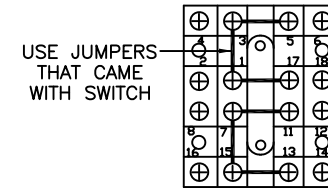
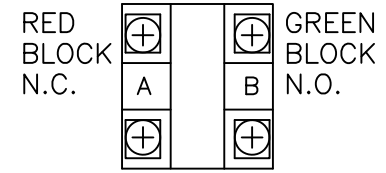

NOTES:

- 1. SW1 ESTOP (PUSHLOCK, TWIST TO RELEASE) 1 MAINTAINED N.C.&N.O. CONTACT
- 2. SW2&3 ARE MECHANICALLY INTERLOCKED, 2 THREE SPEED MOMENTARY 3 N.O. & 1 N.C. CONTACT EACH. TYPE 55S17.
- 3. CONTACTS RATED 5A @ 120 OR 250VAC MAX, 2A @ 24VDC, .4A @ 120VDC.
- 4. YELLOW HIGH IMPACT ENCLOSURE, STANDARD CABLE ENTRY AND HOUSING DEPTH.
- 5. UL LISTED, CE MARKED, NEMA4X RATED AS ASSEMBLY

| REV | REVISION DESCRIPTION | DATE | BY | CHKD | ECH NO. |
|-----|----------------------|----------|-----|------|---------|
| A | INITIAL DESIGN | 12/11/19 | FWK | | |
| | | | | | |
| | | | | | |
| | | | | | |
| | | | | | |

TOLERANCES

FRAC. ± 1/64

.X ± .015

.XX ± .010

.XXX ± .005

ANGLES ± 1°

UNLESS OTHERWISE SPECIFIED

DO NOT SCALE

B SIZE

| DWG. APPROVALS | DATE | REV. |
|----------------|------|------|
| | | |
| | | |
| | | |

DRAWN FWK 12/11/19

CHK'D

ERICSON

SAFETY IS OUR STANDARD

ERICSON MANUFACTURING COMPANY

1-800-ERICSON • www.ericson.com

| | | |
|---------------------------------|----------------|--------------|
| DWG. TITLE | | |
| 5500 SERIES PENDANTS | | |
| PISTOL GRIP PENDANT WITH E-STOP | | |
| TWO BUTTON - THREE SPEED | | |
| SCALE NTS | PROJ NO. --/-- | SHEET 1 OF 2 |
| DWG. UNIT NO. | | REV |
| 5503-PG3 | | A |

NOTES:

1. SHIPPED WITH POLYBAG CONTAINING RING CRIMP TERMINALS.
2. SHIPPED WITH C8020398B INSTALLATION & OPERATION MANUAL.
3. SHIPPED WITH BUSHING – CABLE RANGE .32IN TO .63IN
4. C1010129 MAIN PENDANT UNIT.
5. POLYBAGGED WITH C8020444 LABEL.

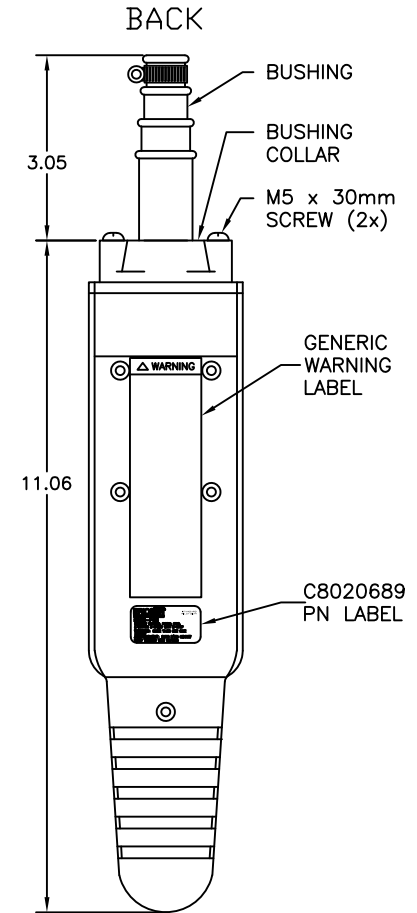
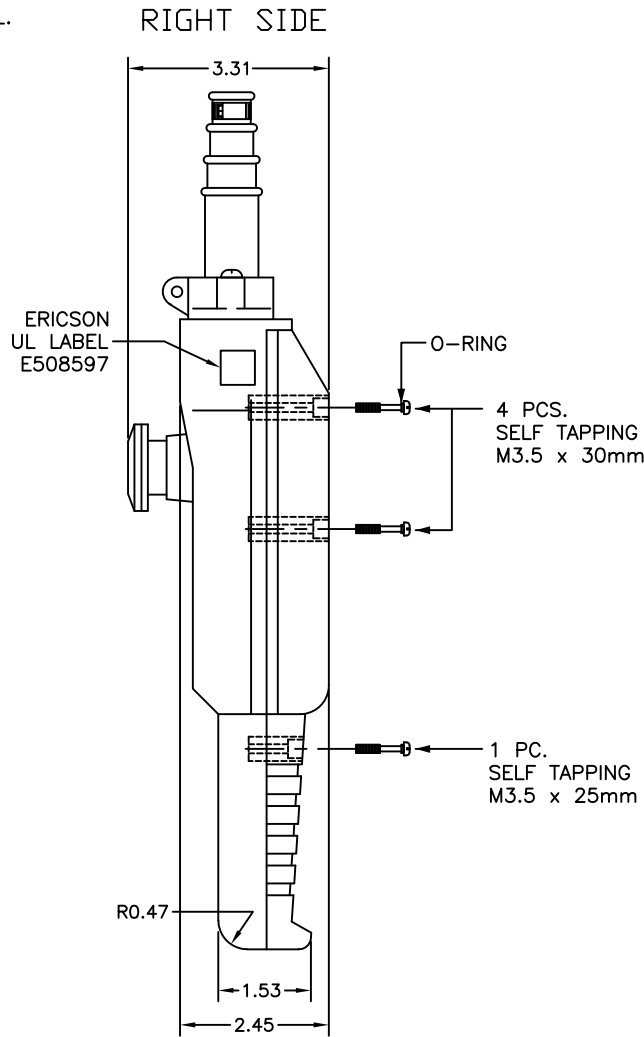

| REV | REVISION DESCRIPTION | DATE | BY | CHKD | ECN NO. |
|-----|----------------------|------|----|------|---------|
| | | | | | |
| | | | | | |
| | | | | | |
| | | | | | |
| | | | | | |
| | | | | | |
| | | | | | |
| | | | | | |
| | | | | | |
| | | | | | |

TOLERANCES
 FRAC. ± 1/64
 .X ± .015
 .XX ± .010
 .XXX ± .005
 ANGLES ± 1°
 UNLESS OTHERWISE SPECIFIED
 DO NOT SCALE
 B SIZE

| DWG. APPROVALS | DATE | REV. |
|----------------|------|------|
| | | |
| | | |
| | | |
| | | |
| | | |
| | | |
| | | |
| | | |
| | | |
| | | |

DRAWN FWK 12/11/19
 CHK'D _____

ERICSON
 SAFETY IS OUR STANDARD

ERICSON MANUFACTURING COMPANY
 1-800-ERICSON • www.ericson.com

| | | |
|---------------------------------|----------------|--------------|
| DWG. TITLE | | |
| 5500 SERIES PENDANTS | | |
| PISTOL GRIP PENDANT WITH E-STOP | | |
| TWO BUTTON - THREE SPEED | | |
| SCALE NTS | PROJ NO. --/-- | SHEET 2 OF 2 |
| DWG. UNIT NO. | | REV |
| 5503-PG3 | | A |