

**CECO**  
ENVIRONMENTAL

**Sethco**

**THERMOPLASTIC  
CHEMICAL SUMP  
PUMPS**

UD/UV Series for  
Corrosive Liquids and  
Chemical Transfer

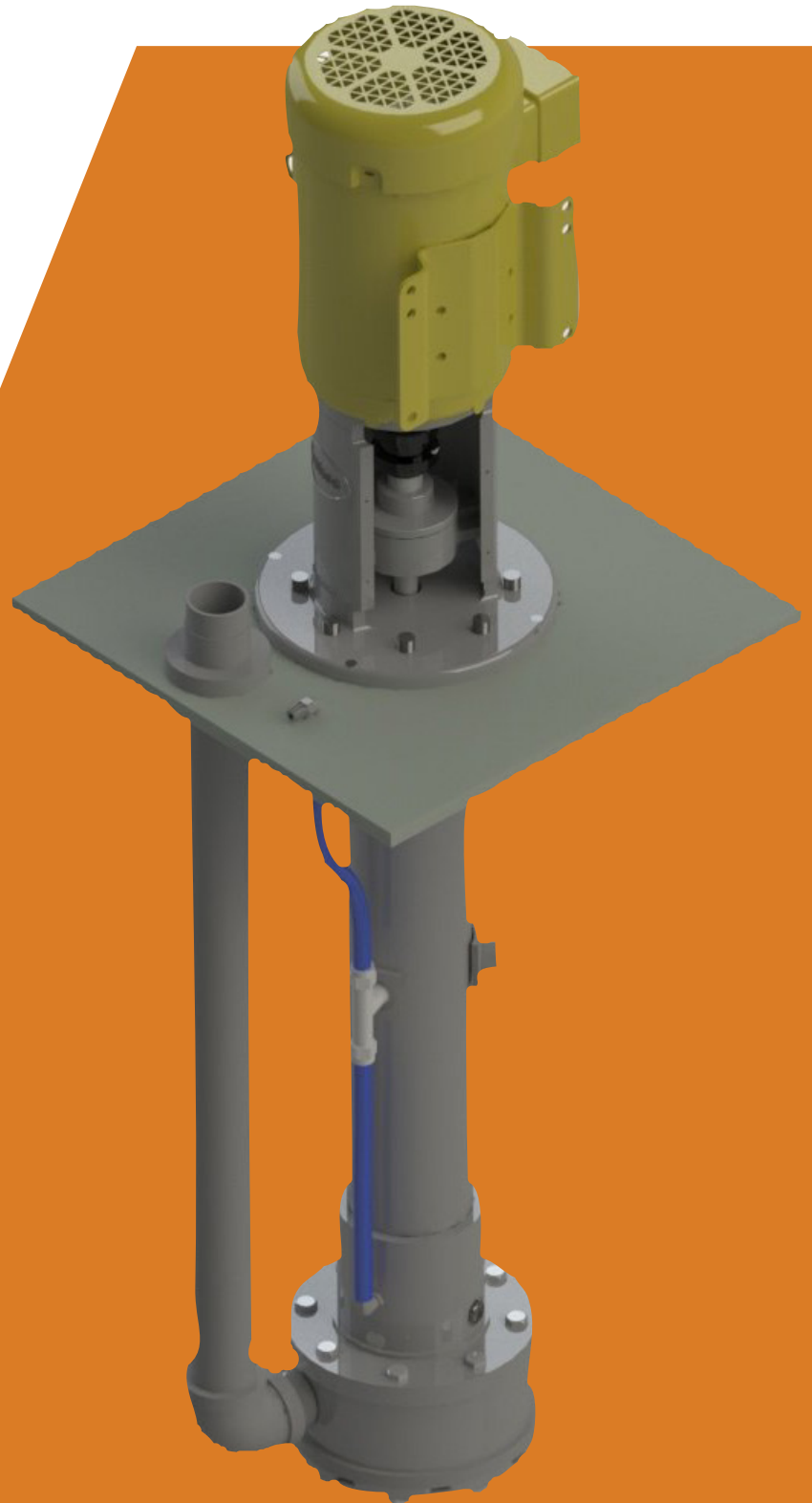

# SETHCO® THERMOPLASTIC CHEMICAL SUMP PUMPS

## UD/UV SERIES FOR CORROSIVE LIQUIDS AND CHEMICAL TRANSFER

- Capacities to 220 GPM (50 m<sup>3</sup>/hr)
- Heads to 135 ft (41 m)
- Standard lengths from 2 to 10 feet (3 m)
- Motors up to 15 hp (11.2 kW)
- CPVC/PVC materials of construction (up to 140° F/60° C)
- All CPVC construction for higher temp applications (up to 180° F/83° C)
- 3168S, Carp-20, Titanium or Hastelloy-C pump shafts

## DESIGN FEATURES

- Internal, external or bypass flush bearing lubrication options
- Non-metallic mounting plate – custom sizes available
- One piece column design adds strength and stability to pump body
- Impeller/casing design permits passage of occasional solid particles and fibrous materials
- Corrosion resistant carbon-filled teflon line shaft bearings
- Maximum 24" (610 mm) bearing span
- Mounts to standard NEMA or IEC frame motors
- Vapor seal designed to protect motor/pedestal from corrosive vapors
- Bearing pedestal includes an oversized double sealed ball bearing

## APPLICATIONS

- Acids
- Bleaches
- Caustics
- Chemical Transfer
- Scrubber/Odor Control
- Water/Wastewater Treatment
- Aquarium
- Plating Solutions
- Quench Tanks
- Pickling Solutions

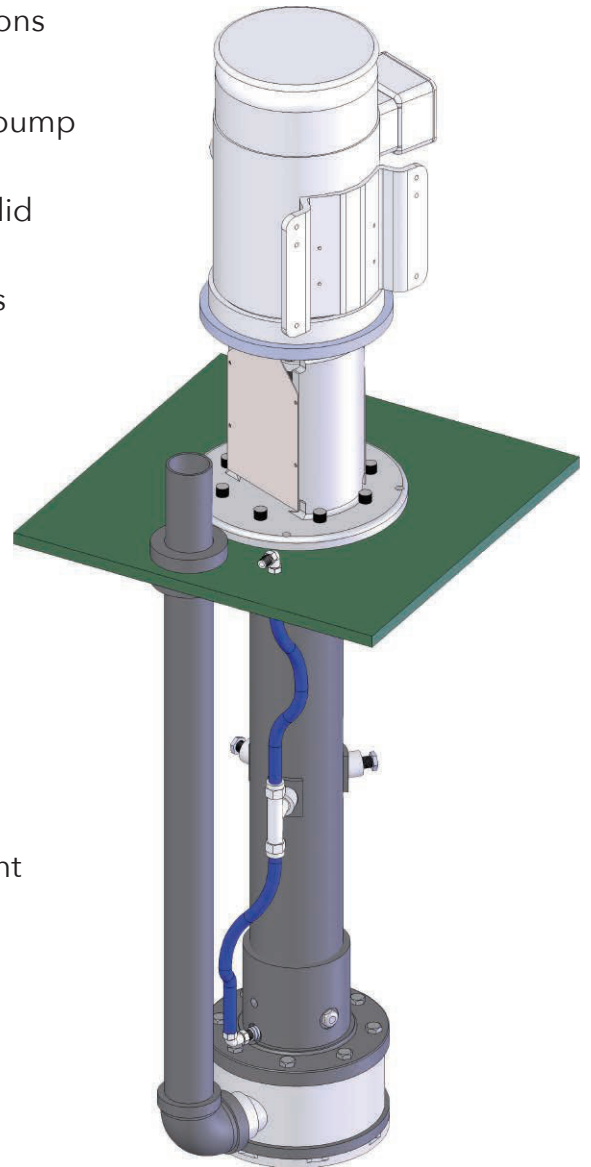

# MODEL UD/UV 60A PERFORMANCE CURVES

RPM: 1750

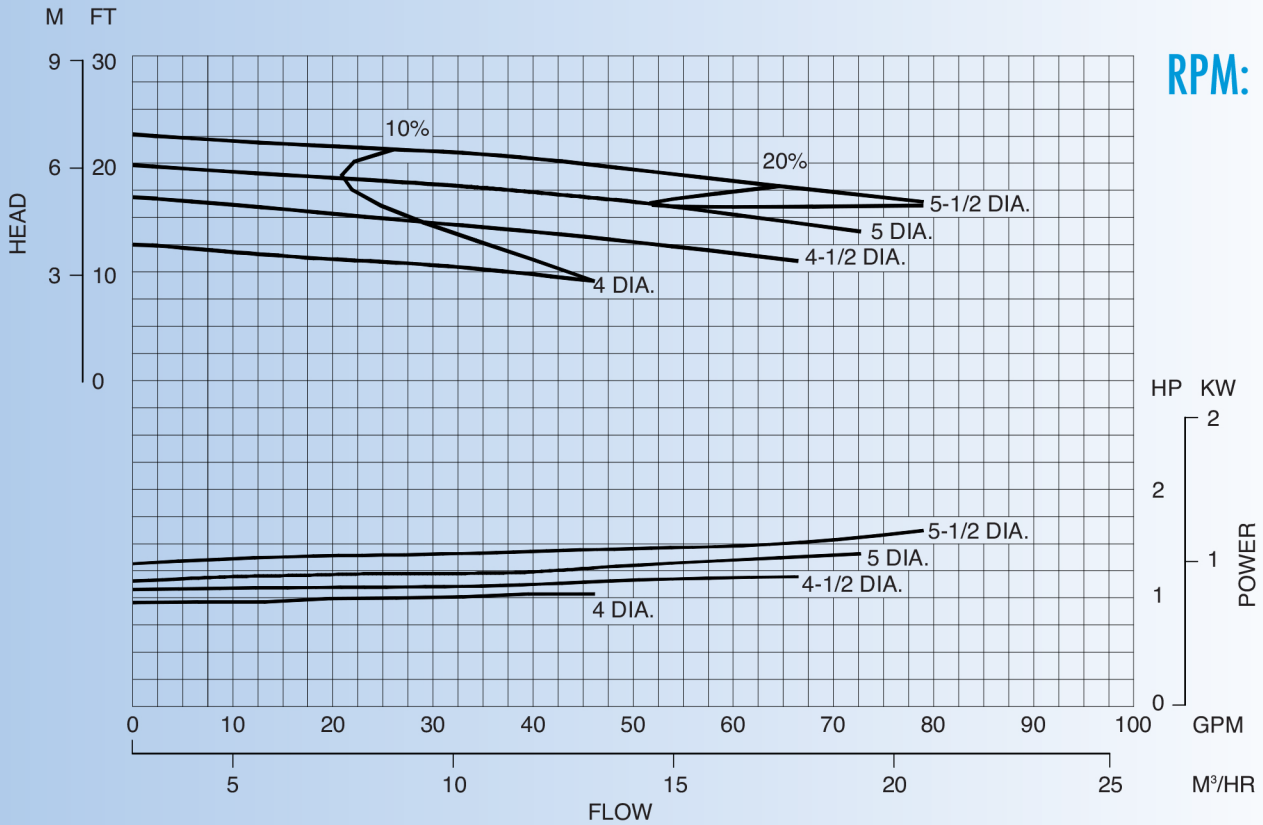

RPM: 3450

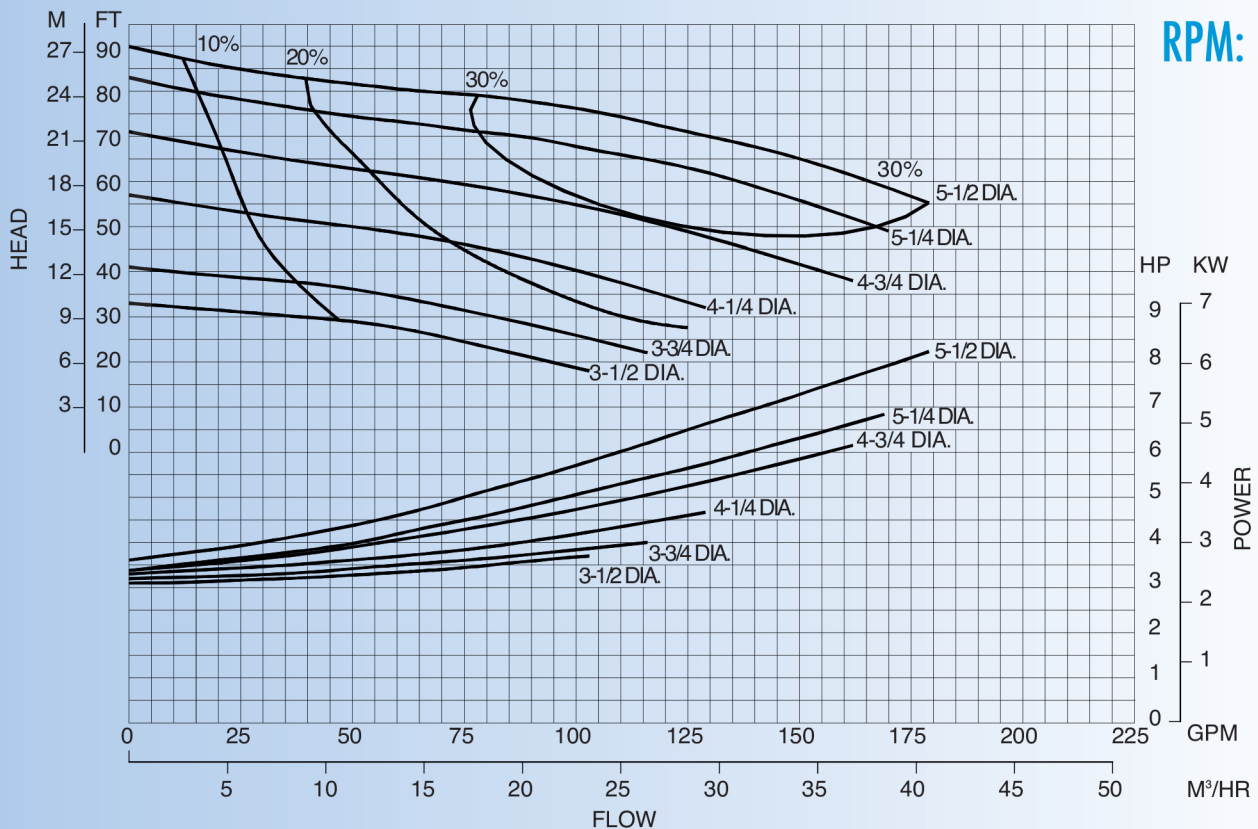

# MODEL UD/UV 80A PERFORMANCE CURVES

RPM: 1750

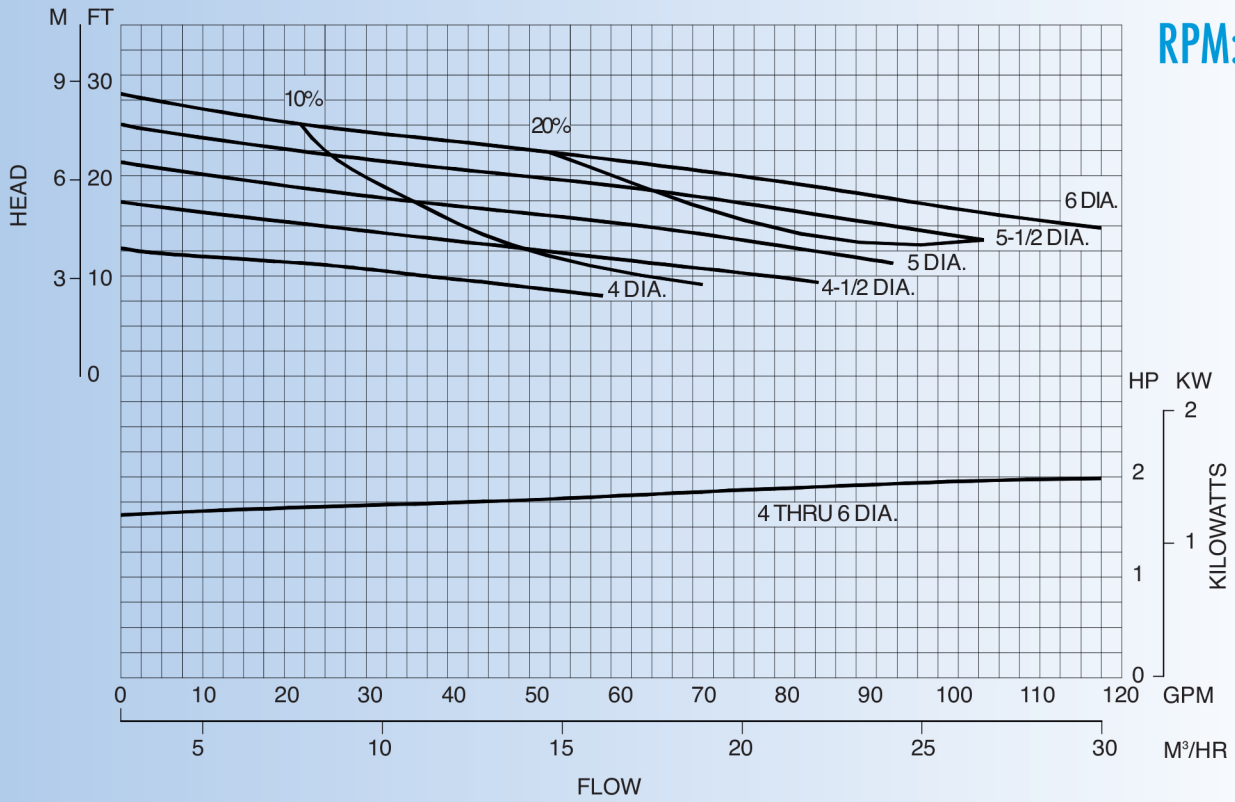

RPM: 3450

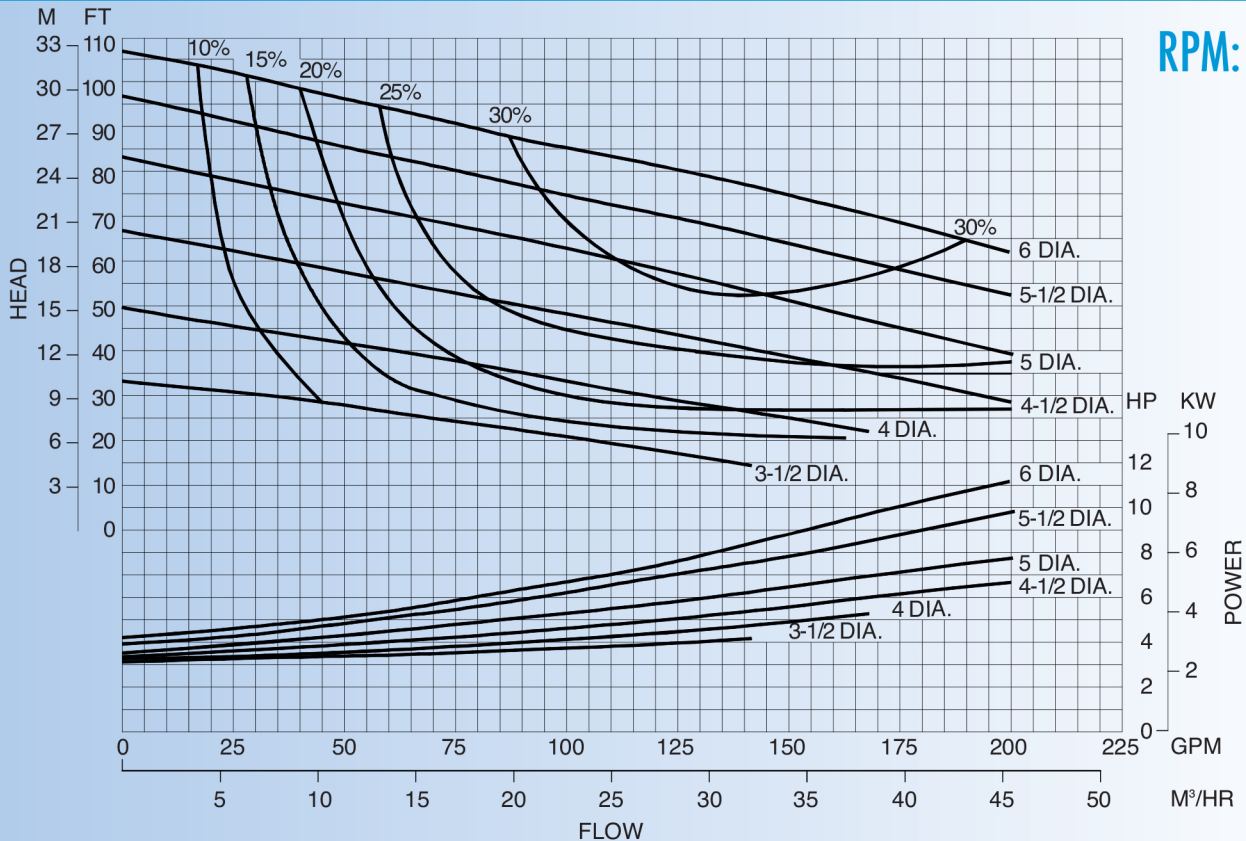



# MODEL UD/UV 100A PERFORMANCE CURVES

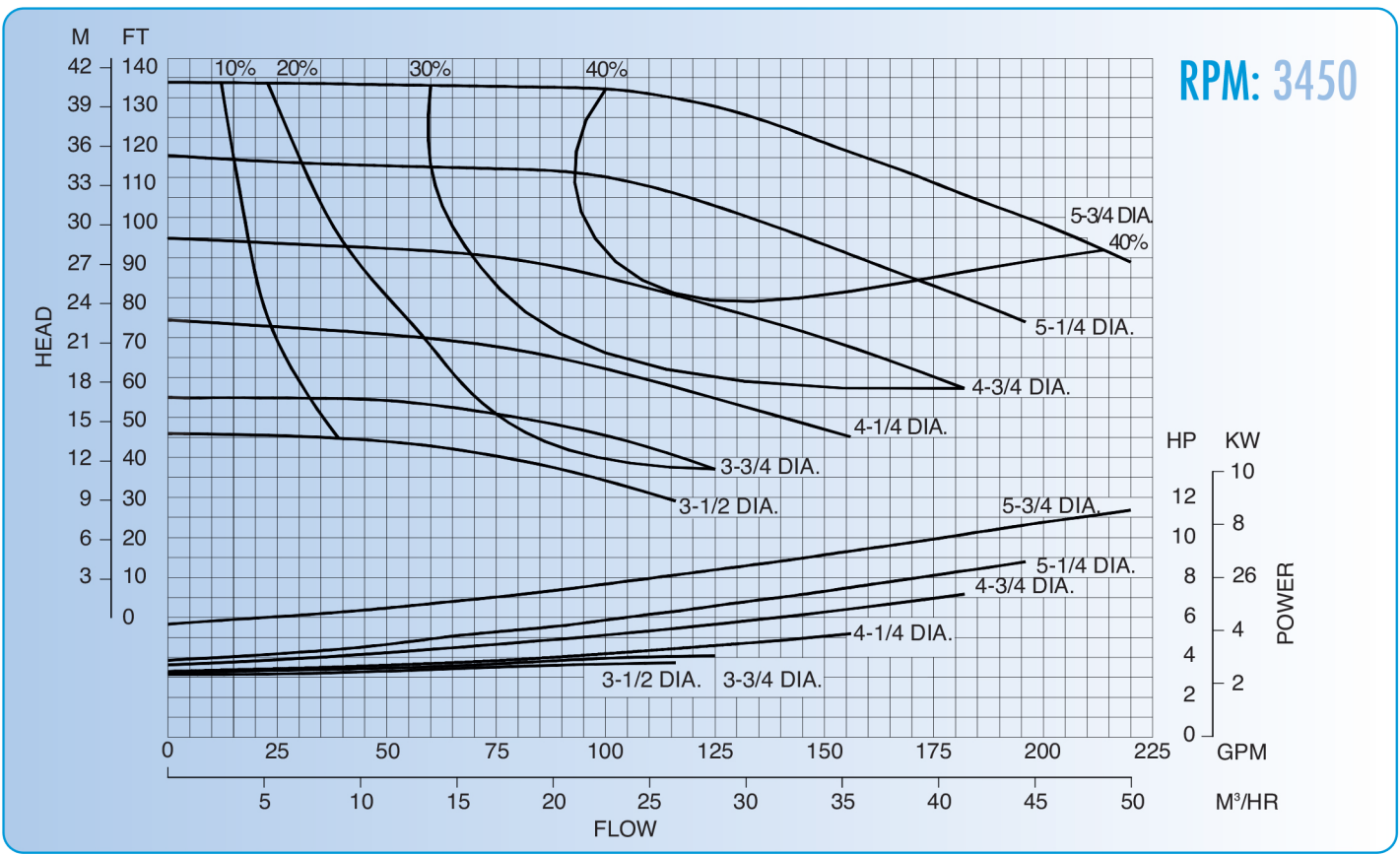
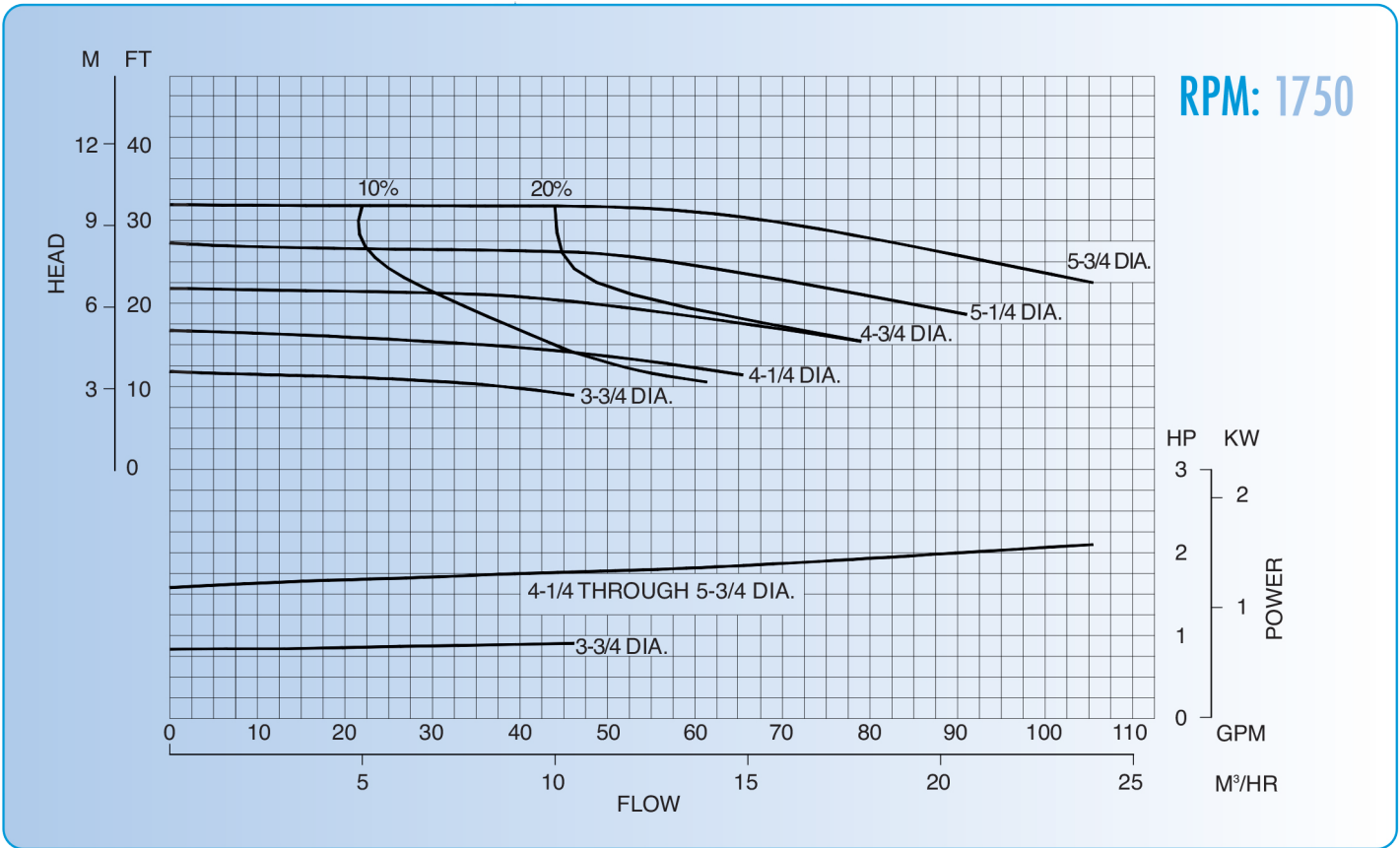

# UD/UV SERIES PUMP ASSEMBLY DRAWING AND PARTS LIST

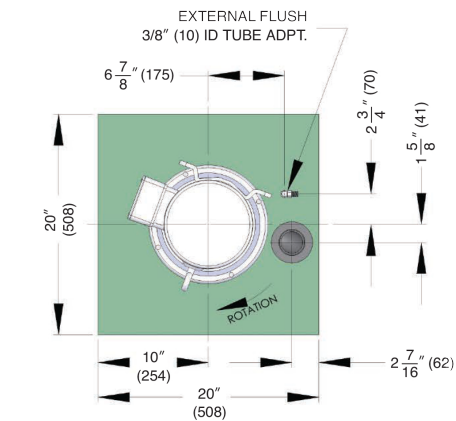

L	Bearings
24" (610)	1
36" (914)	2
48" (1219)	2
60" (1524)	3
72" (1829)	3
84" (2134)	4
96" (2438)	5
108" (2743)	5
120" (3048)	5

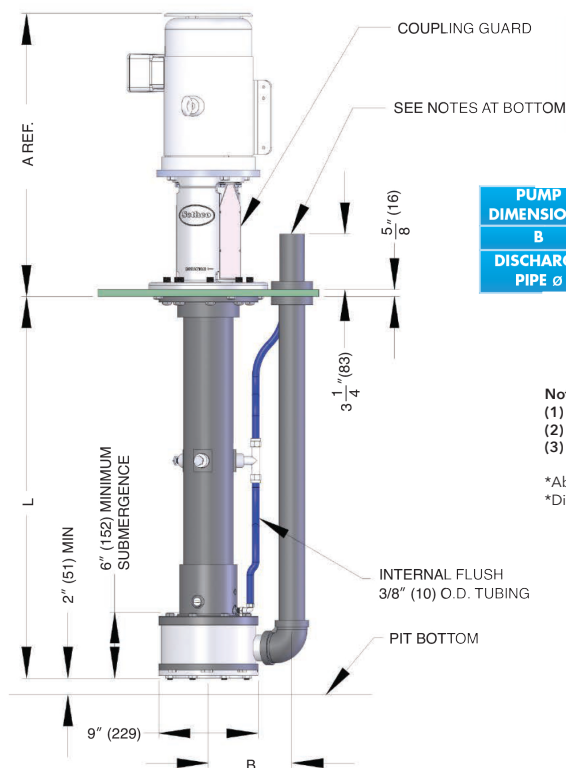

Motor Frame	A
56C	23 5/8" (600)
143TC/145TC	23 5/8" (600)
182TC/184TC	25 5/8" (651)
213TC/215TC	28 3/8" (721)
254TC/256TC	31" (787)

PUMP DIMENSIONS	UD/UV-60A	UD/UV-80A	UD/UV-100A
B	7" (178)	8" (203)	8" (203)
DISCHARGE PIPE Ø	1 1/2" NPT	2" NPT	1 1/2" NPT

## Notes:

- (1) "A" Dimensions vary with motor type and manufacturer.
- (2) Coverplate to be supported on four sides.
- (3) Motor shipped separately for field mounting by others.

\*Above drawing is not to be used for construction purposes.  
\*Dimensions shown are in inches and (millimeters).

## ABOUT CECO ENVIRONMENTAL FLUID HANDLING SOLUTIONS

CECO Environmental Pump Solutions, which combines the resources of the Company's internationally recognized Dean Pump®, Fybroc® and Sethco® brands, is a leading niche-oriented global provider of solutions and products for the pumping of corrosive, abrasive and high temperature liquids. Its broad range of high quality centrifugal pumps provide excellent performance for tough applications including pumping of acids, brines, caustics, bleaches, seawater, high temperature liquids and a wide variety of waste liquids for a broad range of applications including the chemical, petrochemical, metal finishing, wastewater treatment, desalination and aquarium/aquaculture markets. Our Sethco Pump brand is recognized worldwide for its high-quality chemical process and high temperature metallic centrifugal pumps. These pumps are manufactured in a variety of metals to handle a broad range of high temperature and chemical process applications. For more information, visit [www.cecoenviro.com/sethco](http://www.cecoenviro.com/sethco).

## CECO Sethco

700 Emlen Way, Telford, PA 18969

P: 800.645.0500

<https://www.cecoenviro.com/sethco>