

Introduction

The ShockLog® 208 is the base model in the ShockWatch® series of impact recorders, which includes the ShockLog® 248 and ShockLog® 298 impact recorders. Available in 10G, 30G, and 100G scale range settings, the ShockLog® 208 monitors peak acceleration and internal temperature, provides peak value (time slot) and summary period journey profile data.

FEATURES
Record max peaks X, Y, and Z and internal temperature
Field-proven tri-axial piezoelectric accelerometer technology
User-definable alarm levels
LED lights for visual notification of alarms

Contents

ShockLog® 208 Key Features	2
ShockLog® 208 Specifications	3
Factory Fit Specifications	4
Product Construction	4
How to Use the ShockLog® 208.....	5
Communications.....	5
Security	5
Software.....	6
Best Practices for Mounting.....	7
Drawings.....	8
Accessories & Related Products	9
Declaration of Conformity	9
Ordering Information.....	10
Warranty	10
Limitation of Liability.....	11

ShockLog® 208 Specifications

Complete Instrument	
Operating Temperature Range	-40 to 85°C / -40 to 185°F
Drop Test Survival	1m / 39.4in
Dimensions (over connectors & humidity chimney)	84 x 84 x 55mm / 3.3 x 3.3 x 2.2in
Weight (without Battery)	445g / 1.0lbs
Battery	2 x 3.6V Lithium Thionyl Chloride 2 x 1.5V Alkaline Size AA
Battery Life	Up to 12 months w/ Lithium battery
Case Material	Aluminum
Sealing	IP67
Accelerometers	Piezo
Software	Functions on Windows XP, Vista, 7, 8
Communications / Interfaces	
USB 2 Compliant 12Mbps – effective baud rate	256k
iButton	
Indicators	LEDs - 1 Bi-color and 1 Red
A-D Converter Resolution	12 bits
Flash Memory for Data	512kbytes
EMC	
ETSI EN 301 489-17 v1.3.2 (2008-04)	
ETSI EN 301 489-1 v1.8.1 (2008-04)	
EN61326-2-1:2006	
EN301489-17-V2.1.1	
FCC RULES CFR47: PARTS 15.107 & 15.109	
RTCA DO-160F-Section Radiated Emissions Category B	
Data Collection	
Timeslot Interval	10 to 3600 seconds
Maximum Number of Timeslots (depends on slot contents)	15709 to 172800

Accelerometers	
Low Frequency Cutoff (-3dB 10g – 100g)	0.1 - 0.5Hz
High Frequency Cutoff (-3dB)	250 – 300Hz
Resolution (% of full scale) 1% for Peaks	0.1%
Additional Error Peak Capture	±5%
Acceleration Ranges	±10G, ±30G, and ±100G

Factory Fit Specifications

Humidity / Temperature Specifications	
Temperature Measuring Range	-40 to 85°C / -40 to 185°F
Temperature Accuracy	±2°C / ±4°F
Temperature Resolution	0.1°
Humidity Measuring Range	0 - 100% RH
Humidity Accuracy	±3% RH
Humidity Resolution	0.1% RH
Dew Point Measuring Range	-40°C to 85°C / -40°F to 185°F 0 - 100% RH
Dew Point Relative Accuracy (-20 to 70°C, 25 to 75% RH)	±2°C / ±4°F
Dew Point Resolution	0.1°

Product Construction

The ShockLog® 208 has been designed to function reliably in difficult environments. The electronic components are assembled using surface mount technology and the latest automatic assembly equipment. The complete electronic package is coated with acrylic resin and enclosed in the metal case. The securing bolts pass through the body of the instrument to guarantee a reliable mechanical installation.

This construction technique, in combination with the absence of cables for power or sensors results in a very high immunity to electrical interference and very low levels of RF emission. The ShockLog® 208 may safely be used in close proximity to sensitive instruments or in difficult electromagnetic environments.

The ShockLog® 208 has been designed to meet IP67 (including connectors) and is capable of operating at temperatures between -40 and 85°C.

How to Use the ShockLog® 208

Control your ShockLog® device through a simple Windows®-based software program. The software allows for configuration of the ShockLog® 208, data extraction, and analysis. Once configured, mount the ShockLog® 208 to the equipment to be monitored. When the journey is complete, remove the ShockLog and download the recorded information. The ShockLog Report View provides users with an overview of the entire journey. ShockLog® 208 provides peak acceleration values for all three axes reported on a time basis. Additional environmental conditions can be monitored and displayed, if desired. (See Accessories and Related Products below for more information.) Users are able to zoom in for a closer view, or export data into programs such as Excel and MatLab for more detailed analysis. Please refer to the manual for full details.

Communications

The ShockLog® 208 has several mediums of communication. The primary method is via USB. The ShockLog® PC software automatically finds an attached unit so there is no need to identify which USB port is used.

When conditions do not dictate a fixed water tight link a standard cable can be used. An IP67 watertight USB connector is available when conditions warrant its use. The supplied watertight cap should be refitted after communications are complete. Should the cap be left off, the unit remains water tight but the exposed connections may become tarnished which may lead to poor communications.

For a quick and simple way of setting up, starting or stopping a unit in the field, an iButton interface is available. The iButton interface also supports the download of a 'one-page report' giving a condensed view of the journey data gathered.

Security

The ShockLog® 208 stores all data and status information in high performance FLASH memory. This memory requires no power to retain data. The instrument is configured by connecting to a PC and running the data analysis / setup software. During the configuration process the operator has the option of setting passwords in order to limit subsequent access to data.

If passwords have been enabled to restrict access to data, reset the unit or other functions, the user must supply those passwords before the software will communicate with the ShockLog®.

An area of the flash memory is reserved for the security log – this memory records the timing of such actions as resetting the clock or clearing out data and cannot be modified by the operator. It is intended that the security log last the operating life of the instrument and will only be cleared when the ShockLog® is recalibrated at the factory.

Software

The ShockLog® 208 software runs on a desktop or laptop PC using the Windows XP, Vista, Windows 7, or Windows 8 operating systems.

The software allows the operator to configure the ShockLog® 208 and to extract and examine data records from the instrument.

Reports may be viewed onscreen and selected data exported to other applications. Three different reports are available: report, time slot, and log data.

Report:

A top-level view of a mission is presented, providing the user with a single-page report that can be printed or copied into another document. It contains a Time Slots graph and configuration information. The report start and end time can be adjusted to focus on any part of the mission.

Time Slot Report:

Data recorded in the time slot memory can be displayed in graphical form. The following parameters can be available depending on setup and unit specification: date, time, max peak x, y, and z, min peak x, y, and z, internal temperature, humidity, and external temperature.

Security Log Report:

The security log data can be displayed in spreadsheet form. The following parameters are available: date and time of data clearing operations or resets.

Best Practices for Mounting

Mount the ShockLog® close to the most sensitive part of the product being monitored. The ShockLog® should be mounted to a solid, rigid surface and as low as possible. When monitoring long shipments (>20 feet / 6 meters), it is best to mount a ShockLog® at both ends of the shipment.

For best results, it is recommended that the unit be mounted directly to the product being monitored using all four mounting bolts included with the ShockLog®, as shown in the figure below.

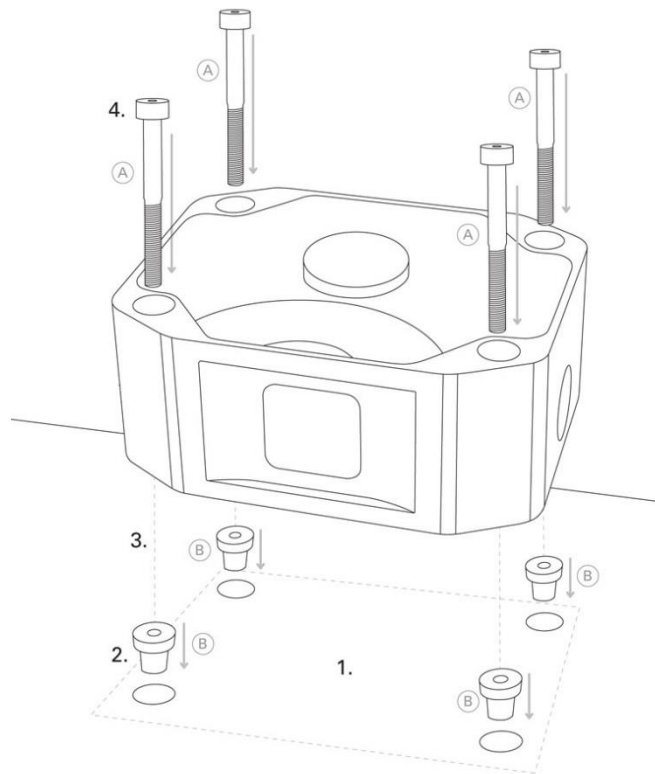

Kit contains:

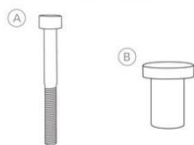

(B) 4 x M5x45 bolts

(C) 4 x black rubber anti-vibration isolation bushings

You will need:

- Electric drill with drill bit between 10.2mm and 10.3mm in diameter
- 5mm allen key

Instructions:

1. Drill 4 (four) $\text{\O}10.2\text{mm}-10.3\text{mm}$ holes in your product to a depth of at least 17mm. Alternatively a mounting plate with the four holes could be mounted to your product.
2. Insert the 4 isolation bushings in the 4 holes, narrow end first.
3. With the ShockLog facing up align bolts with anti-vibration bushings.
4. Push M5 bolts through the holes from front to back. Tighten bolts clockwise with the allen key. Begin with 2 bolts diagonally opposite each other for optimal grip.

ShockLog[®] 208 Technical Data

If it is not possible to mount the ShockLog[®] with mounting bolts, it is possible to use an aggressive adhesive or double-sided tape; however, it is important to remember that the ShockLog[®] should not be free to move inside the shipment.

Additionally, a magnetic mounting plate is available that have been predrilled for the four rubber bushings provided in the mounting kit. See the Drawings section for plate dimensions.

Avoid building special brackets to mount the ShockLog[®]. If a cover is required over the product being monitored, place the cover over the ShockLog[®], but do not attach the unit to the cover.

The ShockLog[®] assumes the axes indicated on the unit. Mount the ShockLog[®] either vertically or horizontally and note the orientation to assist with data analysis.

Drawings

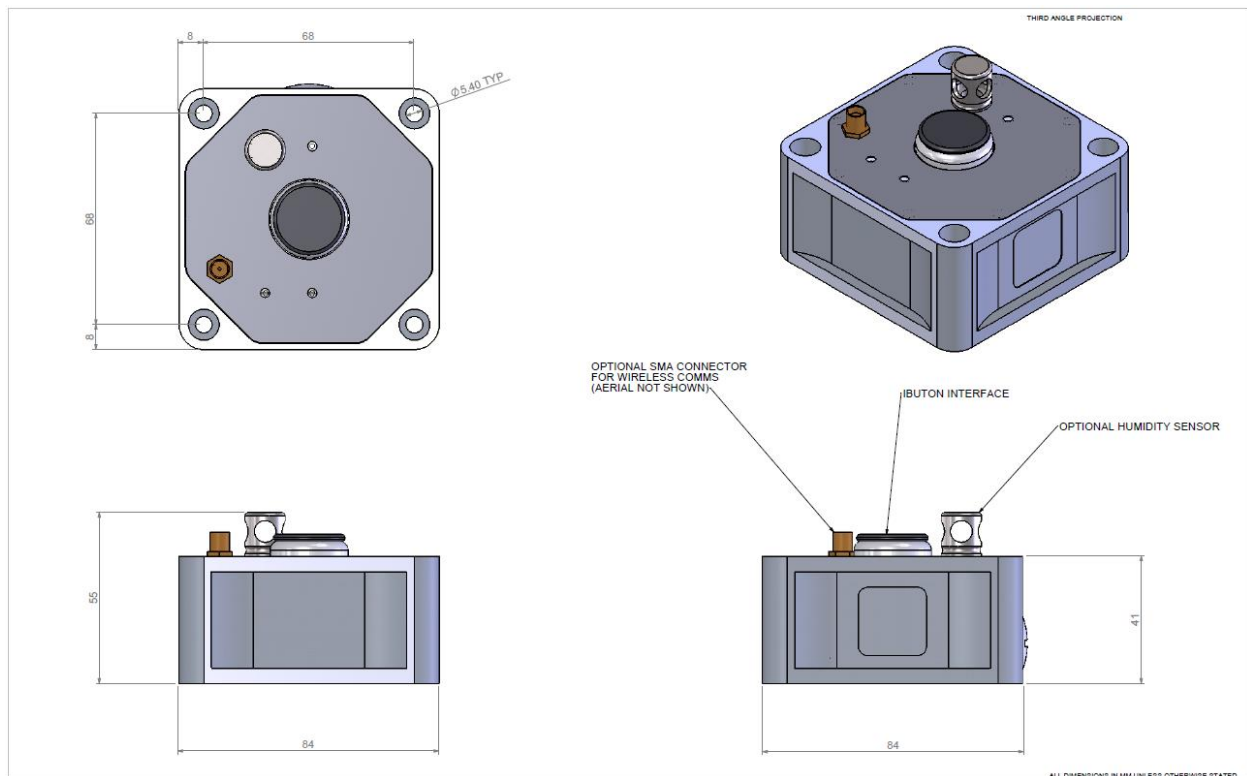

Magnetic Mounting Plate

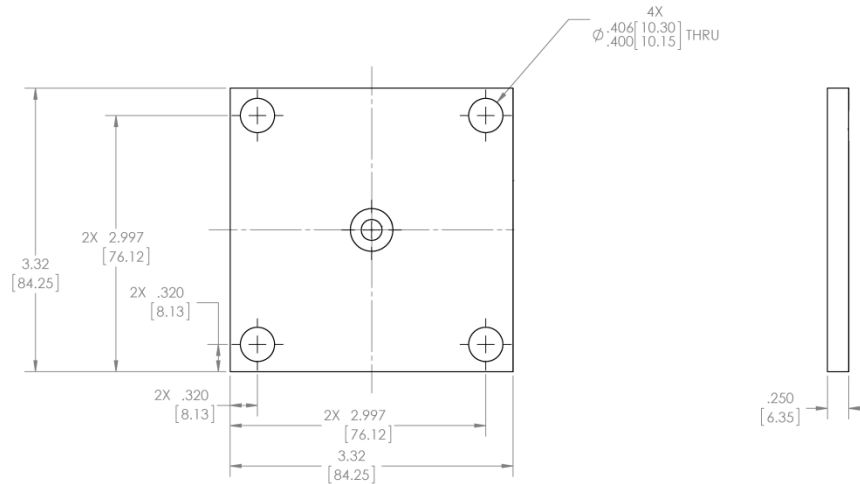

Note: Dimensions in inches

Accessories & Related Products

Batteries, a mounting kit and a companion label are included with each ShockLog® 208. New users of the ShockLog® 208 will be required to purchase a kit in order to get all the necessary accessories and software licenses to correctly operate the device. The kit contains the following items (CD containing software and manual; Quick Start User Manual; USB Communication Cable; and 2 AA Lithium Batteries). iButtons, additional software licenses, and cables can be ordered separately.

The optional Humidity/Temperature Sensor (built-in) can be ordered to extend the conditions monitored by the ShockLog®.

Declaration of Conformity

This ShockLog® product is in compliance with the essential requirements and other relevant provisions of directives, ESTI EN 301 489, EN 61326, FCC Rules CFR47 Parts 15 and RTCA/DO160D. Copies of these Declarations of Conformity are available upon request.

Ordering Information

ShockLog® 208 units include batteries, mounting kit and companion label.

Part Number	Description
SL208-10-A	ShockLog® 208 Unit, 10G 40Hz
SL208-30-A	ShockLog® 208 Unit, 30G 90Hz
SL208-100-A	ShockLog® 208 Unit, 100G 250Hz
SL208-10H-A	ShockLog® 208 Unit, 10G 40Hz w/ External Humidity and Temperature Sensor
SL208-30H-A	ShockLog® 208 Unit, 30G 90Hz w/ External Humidity and Temperature Sensor
SL208-100H-A	ShockLog® 208 Unit, 100G 250Hz w/ External Humidity and Temperature Sensor
SL KIT 208-A	ShockLog® 208 Accessory Kit

Technical Support

If you are unsure of how to use or interpret the ShockLog® 208, please contact ShockWatch Technical Support at (800) 527-9497 or (214) 736-4580.

Warranty

If a product fails to conform to the specifications stated in this document, the product may be returned to ShockWatch at any time prior to the product's specified expiration date or, if no expiration date is specified, within one year from the date of shipment. ShockWatch shall either refund the purchase price (without interest), or repair and/or replace the product (or, in the case of services, re-perform such services) at no additional cost. The warranty is void if the defect has resulted from accident, misuse, abuse or misapplication. Any product which is identified as defective during the warranty period and is returned to ShockWatch with a Return Material Authorization (RMA) number (which must be obtained from ShockWatch prior to any return) within thirty (30) days after discovery of the defect with a written description of the defect will be replaced by ShockWatch.

Limitation of Liability

Seller makes no warranty, expressed or implied, except that the Products sold hereunder shall conform to Seller's written specifications for such Products as in effect and provided to Buyer by Seller at the time of sale of such Products to Buyer ("Seller's Specifications").

WARRANTY SET FORTH ABOVE IS EXCLUSIVE AND IN LIEU OF ANY AND ALL OTHER WARRANTIES, REPRESENTATIONS, AND COVENANTS, EXPRESS OR IMPLIED, STATUTORY, UNDER COMMON LAW OR OTHERWISE. EXCEPT AS PROVIDED IN THE SELLER'S TERMS & CONDITIONS, SELLER MAKES NO, AND EXPRESSLY DISCLAIMS, AND BUYER HEREBY EXPRESSLY WAIVES, IN EACH CASE TO THE MAXIMUM EXTENT PERMITTED BY APPLICABLE LAW, ANY AND ALL WARRANTIES, GUARANTEES, PROMISES, OR REPRESENTATIONS WITH RESPECT TO THE PRODUCTS, WHETHER WRITTEN, ORAL, EXPRESSED, OR IMPLIED, AND WHETHER IN FACT OR BY OPERATION OF LAW, STATUTORY, OR OTHERWISE, INCLUDING, WITHOUT LIMITATION, ANY IMPLIED WARRANTY OF MERCHANTABILITY OR SUITABILITY OR FITNESS FOR ANY PARTICULAR PURPOSE OR ANY WARRANTY OF NON-INFRINGEMENT (INCLUDING PATENT INFRINGEMENT, BOTH DIRECT AND INDIRECT, AND INCLUDING BOTH CONTRIBUTORY AND INDUCING PATENT INFRINGEMENT).

CONDITIONS, BUYER ASSUMES ALL RISK WHATSOEVER, AND SELLER (AND SELLER'S SHAREHOLDERS, DIRECTORS, MANAGERS, OFFICERS, EMPLOYEES, AND OTHER AFFILIATES (COLLECTIVELY, "SELLER'S AFFILIATES")) SHALL NOT BE LIABLE, FOR ANY LOSS, DAMAGE, OR LIABILITY INCURRED BY BUYER OR BY ANY USER OF ANY PRODUCTS ARISING OUT OF THE USE OF SUCH PRODUCTS, WHETHER SINGLY OR IN CONJUNCTION WITH ANY OTHER EQUIPMENT OR PROCESS, AND WHETHER DUE TO THE NEGLIGENCE OF SELLER OR ANY OTHER PERSON OR ENTITY. THE LIABILITY OF SELLER AND SELLER'S AFFILIATES FOR ANY FAILURE OF A PRODUCT TO CONFORM TO SELLER'S SPECIFICATIONS SHALL BE LIMITED EXCLUSIVELY TO, AT SELLER'S ELECTION, EITHER (1) REFUND OF THE PURCHASE PRICE PAID BY BUYER FOR SUCH PRODUCT (WITHOUT INTEREST) OR (2) REPAIR OR REPLACEMENT OF SUCH PRODUCT (OR, IN THE CASE OF SERVICES, REPERFORMANCE OF SUCH SERVICES). IN THE EVENT A COURT OF COMPETENT JURISDICTION SHOULD RULE THAT SELLER OR ANY OF SELLER'S AFFILIATES IS ANSWERABLE IN DAMAGES NOTWITHSTANDING THE LIMITATION OF LIABILITY SET FORTH HEREIN, THE AGGREGATE AMOUNT OF SUCH DAMAGES FOR WHICH SELLER AND SELLER'S AFFILIATES ARE LIABLE SHALL NOT EXCEED THE TOTAL OF ALL PAYMENTS MADE BY BUYER TO SELLER UNDER THE AGREEMENT WITH RESPECT TO THE RELEVANT PRODUCTS. SELLER AND SELLER'S AFFILIATES SHALL IN NO EVENT BE LIABLE TO BUYER OR ANY OTHER PERSON OR ENTITY FOR INDIRECT, SPECIAL, INCIDENTAL, CONSEQUENTIAL, PUNITIVE, OR EXEMPLARY DAMAGES, OR FOR DIMINUTION IN VALUE, LOST PROFITS, OR LOST BUSINESS OPPORTUNITY DAMAGES OF ANY NATURE, ARISING OUT OF OR RELATING IN ANY WAY TO THE PERFORMANCE UNDER OR BREACH OF THE AGREEMENT OR THE PURCHASE OR SALE OR USE OF THE PRODUCTS.

NOTWITHSTANDING ANYTHING TO THE CONTRARY CONTAINED HEREIN, BUYER EXPRESSLY ACKNOWLEDGES THAT SELLER HAS TESTED THE PRODUCTS ONLY AS SET FORTH IN THE SELLER'S SPECIFICATIONS AND NOT FOR USE WITH OR INCORPORATION INTO ANY PARTICULAR APPLICATION, AND BUYER ASSUMES AND BEARS ALL RISK AND RESPONSIBILITY OF DETERMINING THE SUITABILITY OF THE PRODUCTS FOR THE PURPOSE INTENDED BY BUYER OR BUYER'S CUSTOMER. BUYER SHALL NOT MAKE ANY REPRESENTATION TO ANY THIRD PARTY (1) REGARDING THE RELIABILITY OR ACCURACY OF THE PRODUCTS EXCEPT AS EXPRESSLY SET FORTH IN SELLER'S SPECIFICATIONS OR (2) TO THE EFFECT THAT SELLER HAS TESTED THE PRODUCTS FOR THE USE INTENDED BY BUYER OR SUCH THIRD PARTY.

BUYER SHALL INDEMNIFY, DEFEND, AND HOLD SELLER AND SELLER'S AFFILIATES HARMLESS FROM AND AGAINST ANY AND ALL CLAIMS, DEMANDS, LOSSES, DAMAGES, RESPONSIBILITIES, OBLIGATIONS, LIABILITIES, COSTS AND EXPENSES (INCLUDING WITHOUT LIMITATION ATTORNEY FEES, COURT COSTS, COSTS OF ALTERNATIVE DISPUTE RESOLUTION PROCEEDINGS, AND COSTS OF SETTLEMENT) BROUGHT BY ANY PARTY REGARDING PRODUCTS SOLD BY SELLER AND INCORPORATED INTO OTHER ITEMS MANUFACTURED OR SOLD BY BUYER, INCLUDING BUT NOT LIMITED TO ANY CLAIM OF DIRECT OR INDIRECT PATENT INFRINGEMENT.