



Clearing The Airway Is Our #1 Priority

OPERATING INSTRUCTIONS AND MAINTENANCE MANUAL



SSCOR Sentinel Model 2315

SSCOR, INC.

11064 Randall Street • Sun Valley, CA 91352 • USA

Telephone +1-818-504-4054 • 800-434-5211

Fax +1-818-504-6032

www.sscor.com

Email: info@sscor.com

techsupport@sscor.com



Caution-Notice

1. SSCOR suction units are not designed or intended for use in extended procedures that require prolonged high vacuum/low airflow applications, as is the case in wound drainage or endoscopic use or in any other procedure that produces high vacuum levels within an occluded system for an extended period of time. Turn the suction unit off when it is not in use.
2. Federal law restricts this device to sale, distribution, and use by, or on the order of a physician, emergency medical technician, or other medical practitioner. For use by medical personnel trained in suctioning techniques and in the use of medical suction equipment.
3. This manual is restricted to the discussion of the use and maintenance of this device. It does not attempt to discuss professional techniques in suctioning procedures.
4. Operator should be thoroughly familiar with these operating instructions before this device is used.
5. The suction pump must be reconnected to the battery charger after each use and remain connected until needed.
6. Do not use in the presence of flammable agents or anesthetics.
7. The shut-off valve in the canister lid will close down when the canister is filled with fluids.
8. Install a new canister before testing for vacuum over -300mmHg to minimize the possibility of implosion, which can occur when a canister is aged or damaged.
9. SSCOR's battery charger charges batteries only. The battery charger will not run the pump.
10. This unit complies with electromagnetic compatibility standards. Any person who connects external equipment to signal input, signal output, or other connectors has formed a system and is therefore responsible for the system to comply with the requirements of IEC 60601-1-2. If in doubt, contact a qualified technician or your local representative.

SSCOR Sentinel Model 2315 Series
Battery operated portable suction pump
©2014 HI-D and Big Stick are registered trademarks of SSCOR, Inc.

Table of Contents

Caution-Notice	2
General Description and Symbols	3
Getting Acquainted- Basic Instructions	4
General Specifications-Trouble Shooting	5
Warranty-Maintenance	6
Sanitation and Disinfection.....	7
Internal Access-Internal Components	8

General Description



The SSCOR Sentinel is a portable, 12V DC battery operated suction pump for constant suctioning during resuscitation emergencies. It is powered by sealed lead acid batteries, capable of driving the unit for 45 minutes \pm 10%. The batteries are recharged by a 115V AC to 13.8V DC Dual Mode Charger (included with the unit). A sealed lead acid battery is a very stable and reliable battery. Many factors can affect the life of a battery:

- Leaving a unit switched on after there is no longer enough power to run the pump can cause a battery to deep discharge. This can reduce the life of, or destroy the battery.
- Failing to charge a battery for an extended period of time will also cause the battery to go into deep discharge.
- Low temperatures may reduce the available capacity.
- High temperatures may cause deformation of the battery case and damage the battery.

Sealed lead acid batteries can easily be maintained to permit proper operation of the equipment. To protect the battery, after each procedure turn the unit off, put the unit on charge and always store the pump at room temperature. The only way to assure the battery has functional capacity, even if it is indicated the battery is fully charged, is to perform the battery test suggested on page 4 of this operations manual.

The Sentinel is designed to provide instant, effective suctioning, independent of external sources of power and can be pre-set to be activated immediately upon reaching the distressed patient. Suction power is controllable for those instances when full power would be considered harmful to the patient. The SSCOR Sentinel is equipped with a disposable collection canister which features a bacterial filter to screen airborne particulates and a mechanical shut-off valve to prevent fluid overflow.

Description of Symbols

Symbol	Meaning	Location
	Type B Medical Equipment	Serialized Label
	Serialized Label	Separate Collection for Electronic Equipment
	Serialized Label	Caution - Consult Accompanying Documents

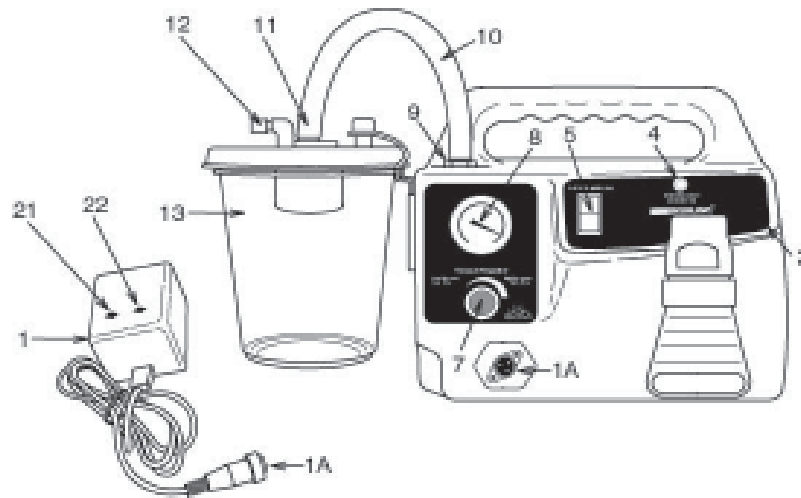

Getting Acquainted

Charging the Battery

1. Connect the dual mode battery charger (1) to a grounded wall receptacle.
2. Connect the female plug of the battery charger (1A) to the facing side of the unit (1A).
3. Check the control panel (2). The "power source connected" red LED (4) indicates a good connection between the Sentinel and the charger.
4. Check the LED's on the battery charger (1). "Power On" (21) indicates a good connection to the AC power source. "Fast Charge" (22) will light when the battery is charging and go out when the battery is fully charged. When the "Fast Charge" (22) light is out, you can test the charging mode by flicking the switch (5) to the "On" position and back "Off". The "Fast Charge" (22) light should come on immediately.

For Optimal Performance

1. The suction device is to remain plugged in whenever the device is not in use.
2. If for any reason poor battery quality is suspected, the customer is to perform a battery test.

Battery Test

Run the following test whenever poor battery quality suspected to ensure proper performance of the device.

- Confirm the power cord is supplying power to the device. Check the power indicator light on the control panel.
 - Remove the power cord and run the unit from its internal DC battery.
 - Check the vacuum by occluding the patient tube and set the vacuum regulator to the maximum vacuum setting.
 - Observe the regulator gauge. The vacuum reading should rise to -300mmHg from zero in less than 3 seconds. It should max out at $\geq -525\text{mmHg}$. Un-occlude the patient tubing.
 - Allow the unit to run for 15 minutes on the DC power. If the unit stops or slows during the 15 minutes, or if the battery condition indicators begin to blink, it is possible the battery capacity has been depleted. It is time to replace the battery.
 - If the unit is still running at full power after 15 minutes, adjust the regulator to the desired setting, turn the device off and put it back on charge.
 - Note: If the vacuum does not reach -525mmHg, check for a leak in the system i.e. vacuum tubing, barb connections or loose canister lid. Refer internal vacuum problems to qualified personnel.
 - Reconnect the unit to the charging source as soon as possible after each use.
- SSCOR recommends replacement of the battery after 3 years.

General Specifications

CHARACTERISTICS	SPECIFICATIONS
Size	17"L x 9"H x 6"W (43.2cm L x 22.9cm H x 15.2cm W)
Weight	8.5 lbs. (4.1 Kgs.)
Vacuum Pump	12V DC oil-less diaphragm. 3.0A Exceeds -525mmHg Clinical Airflow >= 30LPM
Variable Regulator (7)	Controls vacuum from < -50 to >= -525mmHg
Gauge (8)	Calibrated in mmHg. Color-coded.
Power Source: Battery (DC Power)	Rechargeable Sealed Lead Acid. 45 (±10%) minute running time.
Switch (5)	On/Off rocker switch
Collection Canister (13)	1200cc/ml SSCOR part #48041
Patient tubing	Vinyl tubing 9/32"ID, 72"L SSCOR part #43200
Suction Tip	HI-D® "Big Stick®" SSCOR part #44241

Trouble Shooting

PROBLEM	POSSIBLE CAUSE	CORRECTIVE ACTION
Does not function when switch is on	Battery discharged	Reconnect to battery charger
Power source connected indicator light not lit	Fuse blown	Refer to Bio-Med
	Bad connection	Refer to Bio-Med
No suction when pump is running	Vacuum line (10) loose	Tighten
	Canister(13) damaged	Replace
	Canister lid (13) loose	Tighten
	Catheter thumb vent (6) is open	Occlude
	Debris has collected in pump	Refer to maintenance section of this manual

Warranty

SSCOR warrants that each new product is free from defects in material and workmanship under normal use and service for a period of one year from date of purchase. If returned to SSCOR, we will arrange for repairs or replacement within the terms of the warranty. The product should be decontaminated and returned properly packaged and postage prepaid. Loss or damage in transit to the factory shall be at the purchaser's risk. Please call 800-434-5211 or international +1 818-504-4054 for return authorization or for the location of an authorized repair center. Loss or damage in return shipment from SSCOR shall be at the purchaser's risk.

The warranty shall not apply to any SSCOR product which has been repaired by anyone other than an authorized SSCOR representative, or altered in any way so as, in SSCOR's judgment, to affect its safety or efficacy, nor which has been subject to misuse, negligence, or accident, nor which has had the serial number altered, effaced or removed. Neither shall this warranty apply to any SSCOR product which has been connected otherwise than in accordance with the instructions furnished by SSCOR.

This warranty is in lieu of all other warranties expressed or implied and of all other obligations or liabilities on SSCOR's part, and SSCOR neither assumes, nor authorizes any representative or other persons to assume for it, any other liability in connection with the sale of SSCOR products.

This warranty gives you specific legal rights and you may also have other rights that vary from jurisdiction to jurisdiction. For countries where minimum warranty terms are determined by statute, the warranty term is the longer of the statutory period or the term listed above.

Batteries, disposable items including collection canisters, patient tubing and catheters are excluded from this warranty

Maintenance

Preventive Care

Observe the following maintenance routine to ensure readiness at any time:

1. When the SSCOR aspirator is not in use, keep batteries on continuous charge.
2. Test the SSCOR aspirator at regular intervals; See page 4.
3. Make sure the SSCOR aspirator is always clean and ready for use.
4. If the procedure produced an excessive quantity of fluids, check the vacuum line (1) for evidence of moisture. If the vacuum line between the pump and canister is moist, it is possible that fluids have reached the vacuum pump. See Disinfection Instructions (page 7).
5. If the vacuum pump appears defective, return the unit to the factory for repair. Do not attempt to repair the vacuum pump.
6. For technical assistance, call (800) 434-5211 or international +1 (818) 504-4054.

Maintenance

Sanitation

As soon as possible after use, the single use disposable canister, patient tubing and catheter should be discarded according to local / regional / national requirements for the disposal of hazardous waste materials. Clean the exterior of the SSCOR suction unit using a mild detergent and clear water by dampening a clean lint free cloth. Rinse using clear water and another damp clean lint free cloth to remove any detergent residue.

NOTE: The hydrophobic filter in the canister helps to ensure that no moisture or particulate matter reaches the inside of the device. When fluids fill the canister, the positive (mechanical float) shutoff valve closes immediately, shutting the vacuum port off so as to prevent fluid from contacting the pump. The filter has been tested by the manufacturer (Bemis) to screen out aerosolized microorganisms and particulate matter at a bacterial efficiency rating of 99.99% DOP. The canister also has sidewall gradation marks starting at 100 ml/cc and at every 50 ml/cc up to 1200 ml/cc indicating the fill level of the canister.

In the unlikely event that fluids may have reached the vacuum pump, read the disinfection section. Your engineering department will have to open the unit to check the condition of the pump.

Do not reuse any single use disposable parts; do not submerge the device into any liquid, this will void the warranty and cause the device to malfunction.

Disinfection

Use personal protective equipment such as gloves, a smock, and face and eye protection when handling units that are suspected to be contaminated.

Part

Cleaning and Disinfecting

Collection Canister	Disposable item, re-use not permitted. Use new canister for each patient.
Patient Tubing	Disposable item, re-use not permitted. Use new patient tubing for each patient.
HI-D® Stick	Disposable item, re-use not permitted. Use new HI-D Stick for each patient.
Vacuum Pump	Wipe with damp cloth or disinfectant wipe. Sterilization not permitted. Vacuum pump should be replaced if contaminated.
Chassis	Wipe with damp cloth or disinfectant wipe. Sterilization not permitted.

Caution: Disconnect the unit from any power source prior to cleaning the unit.

Disinfect the unit using a mild surface disinfectant, such as a 10:1 mixture of water and bleach. The unit is designed to suction contaminated fluids, which should be removed from the system immediately after use. In the unlikely event that fluids may have reached the vacuum pump, your engineering department will have to open the unit to check the condition of the pump. When cleaning the interior of the chassis, disconnect the battery from the wiring harness. The only foreseeable way fluids may reach the vacuum pump is the filter in the canister has been compromised or bypassed.

For technical assistance, call (800) 434-5211 or +1 (818) 504-4054.

Internal Access for Electrical and Pneumatics
**WARNING: DO NOT ATTEMPT TO SERVICE THIS EQUIPMENT
 IF YOU ARE NOT A QUALIFIED MEDICAL REPAIR TECHNICIAN**

To open the unit, first remove the canister holder:
 Remove the set screws on the canister bracket. Lift canister holder up and out of the main chassis.

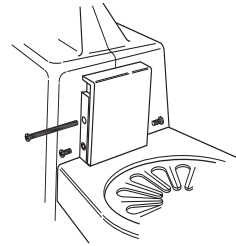

The clamshell design enables access to internal components. All 6-32 phillips head fastening screws are located in back of the unit.

REMOVE MAIN CHASSIS SCREWS

- (A) 1 screw under the canister holder
- (B) 2 screws in the back of the handle
- (B) 3 screws in the back of the main chassis.
- (C) It should not be necessary to open the exhaust door unless fluids have entered the system

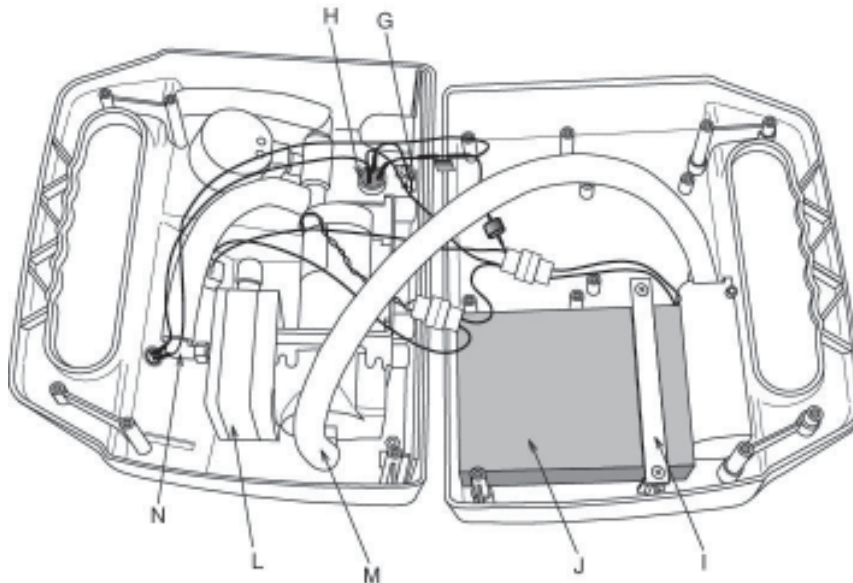
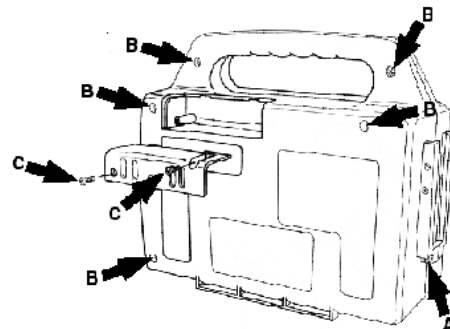

- (G) Ground is connected between the receptacle and the pump bracket.
- (H) DC receptacle
- (I) Battery Bracket
- (J) Battery, 12V, Sealed Lead Acid
- (K) N/A
- (L) Vacuum pump. Return to SSCOR or authorized service center for service. Do not attempt to service the vacuum pump.
- (M) Exhaust barb
- (N) Vacuum barb