



ø5 - ø78 mm

ø0,25 to ø3 "

- Ø 0,25" to 3": very **wide range** of use
- **Cutting precision:**
 - perpendicular cuts < 0.25 mm
 - seamless cutting

Weight: 15 kg / 33 lbs (easy handling)

- **Ideal for use at worksites**

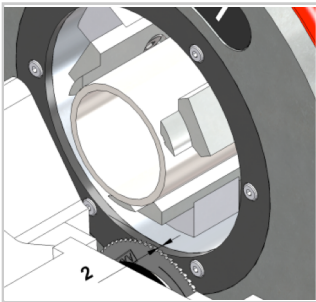

Blade-jaws distance of 2 mm
Limits vibration and distortion with thin and small-diameter tubes



Concentric clamping with 3 jaws in **stainless steel** to eliminate tube distortion

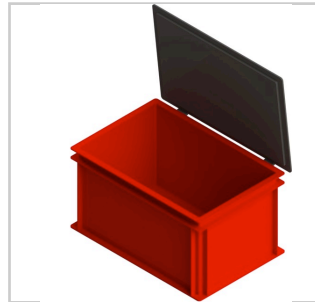

Worksite carry case



Adjustment via the speed changer

References	Motors	Accessories	Consumables
81M21	M21 : Metabo 230V mono Thickness < 7mm	CCSER1/CCSER2: simple/bearing stand	LS6872 : 1 to 3 mm
81M11	M11 : Metabo 120V mono Thickness < 7mm		LS6844 : 2 to 7 mm
	All motors are delivered in their individual case, including the necessary tools		LS63100 : 0.7 to 1,5 mm
			CCLUP: lubricant

