

∅38 - ∅220 mm

∅1,5" - ∅8,625"

- Ideal for Multi-pass welding up to 12,7 mm thickness
- AVC regulation of the position of the electrode (20 mm stroke)
- Oscillation OSC capacity: 20 mm stroke
- Symmetrical quick clamping through lever
- Motor with encoder : allows for tungsten electrode start-up at all angles and a wide range of diameters
- Axial adjustment of the electrode
- Low rotating free space around the tube: 175 mm radius from center of tube
- Compatible with AVC/OSC module upgrade

Weight: 15,1Kg / 33 lbs (without cables)

Very compact design
Two motor positions available

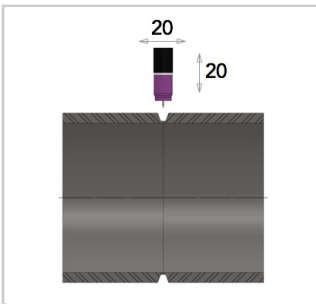

Oscillation stroke :20mm
AVC stroke : 20 mm
Max speed: 15mm/s

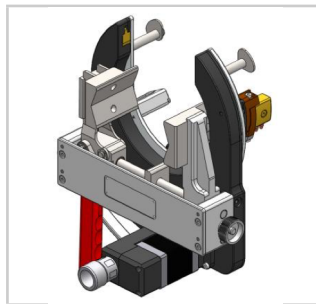

SATO-xxxE31: Straight motor
Symmetrical clamping

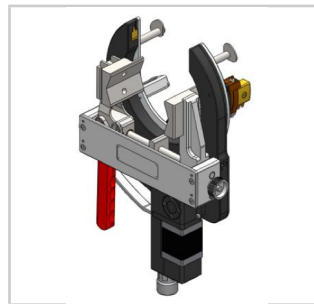

SATO-xxxE32 : Angle transmission motor
Symmetrical clamping

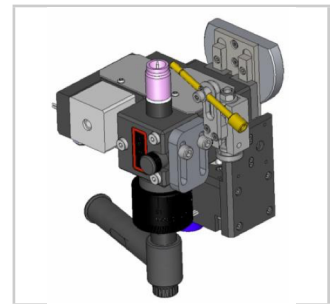

SOAF: AVC/OSC module

References	Accessories	Consumables
SATO-220E31 SATO-220E32	SAFS-310 : Wire harness extension 10 M SKIB-01: gas protection kit - plugs ∅6 to 41 mm SKIF-01: gas protection kit - membranes ∅40 to 120 mm	SCE16-50 : ∅ 1,6 mm SCE24-50 : ∅ 2,4 mm

