

Ø19 - Ø80 mm

Ø0,75" - Ø3"

- **Water cooled welding torch**
- Mechanical Roll tracking: insures electrode distance without marking the tube
- Symmetrical quick clamping through lever
- Motor with encoder : allows for tungsten electrode start-up at all angles and a wide range of diameters
- Axial adjustment of the electrode
- Low rotating free space around the tube: **90 mm** radius from center of tube

Weight: 4,2 Kg / 7 lbs (without cables)

Very compact design
Two motor positions available

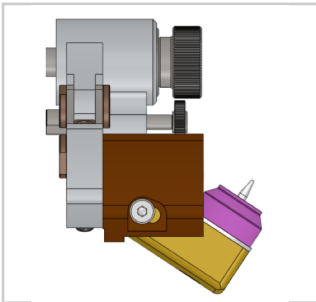

Torch angle adjustment: welding under flange or short T angle

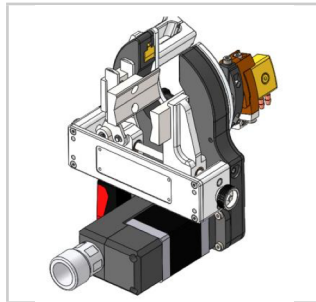

SATO-xxxE01: Straight motor
Symmetrical clamping

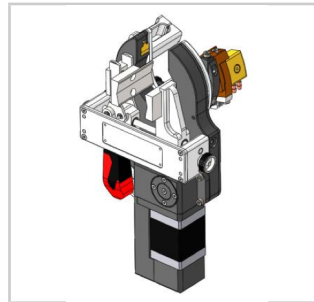

SATO-xxxE02 : Angle transmission motor
Symmetrical clamping

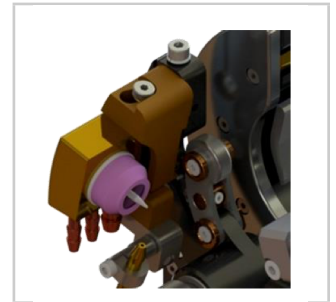

Mechanical roll tracking: Constant arc voltage and roll tracking avoiding marking the tubes

References	Accessories	Consumables
SATO-80E01	SAFS-210 : Wire harness extension 10 M Except with AVC/OSC/ WIRE	
	SKIB-01: gas protection kit - plugs Ø6 to 41 mm	
SATO-80E02	SKIF-01: gas protection kit - membranes Ø40 to 120 mm	SCE16-50 : Ø 1,6 mm
	SATOB-02B : Wire guide two axis for SATO	SCE24-50 : Ø 2,4 mm
	SKTO-01 : Exchange kit for open head torch diam 1.6 and 2.4mm	
	SADF-2: wire feeder for SP and SATO (without wire spool)	

