

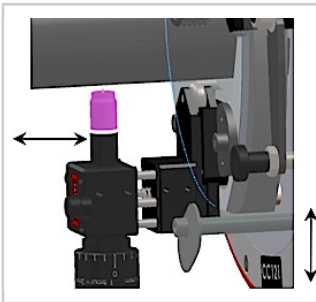

Ø59 - Ø225 mm

- Morse **inox** di base da Ø116 a Ø219 mm
- Morse ausiliari inox inclusi da Ø 59 a Ø169mm
- **Rotazione elettrica autoline 120 V - 230V**
- Ampio range di diametri
- **Raffreddata ad acqua:** corrente max 200A al 100%
- **Evolutiva:** trasformabile in macchina per taglio e smusso orbitale

Peso: 59 kg



Regolazione assiale per posizionamento preciso

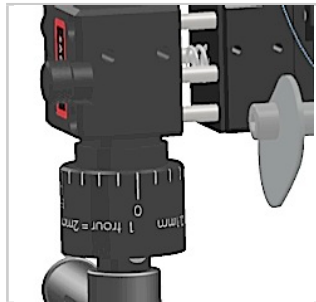

Regolazione radiale per posizionamento preciso



Commando de Stazione AXXAIR



Guida profilo meccanica: tensione arco costante

Codici	Accessori	Consumabili
SP221-E	<p>CCPS21: piede di supporto</p> <p>FS29 / FS25: 230 V FS19 / FS15: 120 V</p> <p>GA10-2-xxx: 230 V GA10-1-xxx: 120 V</p> <p>CCSA21: Serraggio pneumatico per 121 / 171 /221 e DC115-BM/DC221-BM</p> <p>CCSER1/ CCSER2: cavalletto treppiede</p>	<p>SCE16-50 Ø 1,6 mm</p> <p>SCE24-50 Ø 2,4 mm</p>

