

# Framing & Electrical Rough-in for Recess Mount IS Panel System

## Overview

Careful pre-planning and design lay-out are critical to successfully installing a Recess Mount IS (Infra-Sauna) Panel System. The basic concept is to apply horizontal furring strips to your existing vertically framed stud walls. This will allow “window frame” openings that the Recess Infrared (I.S.) Panels will fit into. Standard 1x2, (3/4” x 1.5” actual dimension) furring strips will work the best but 3/4” plywood ripped to dimension will work just as well. Always use straight lumber when framing out your panel openings!

Although this tutorial is based on vertically mounted tongue and groove (T&G) wall paneling, it can easily be adapted for horizontally mounted T&G by furring out all stud faces that are not within the “window frame” openings. For clarity, all furring strips in this document have been covered with blue tape. It is not necessary to do this on your project.



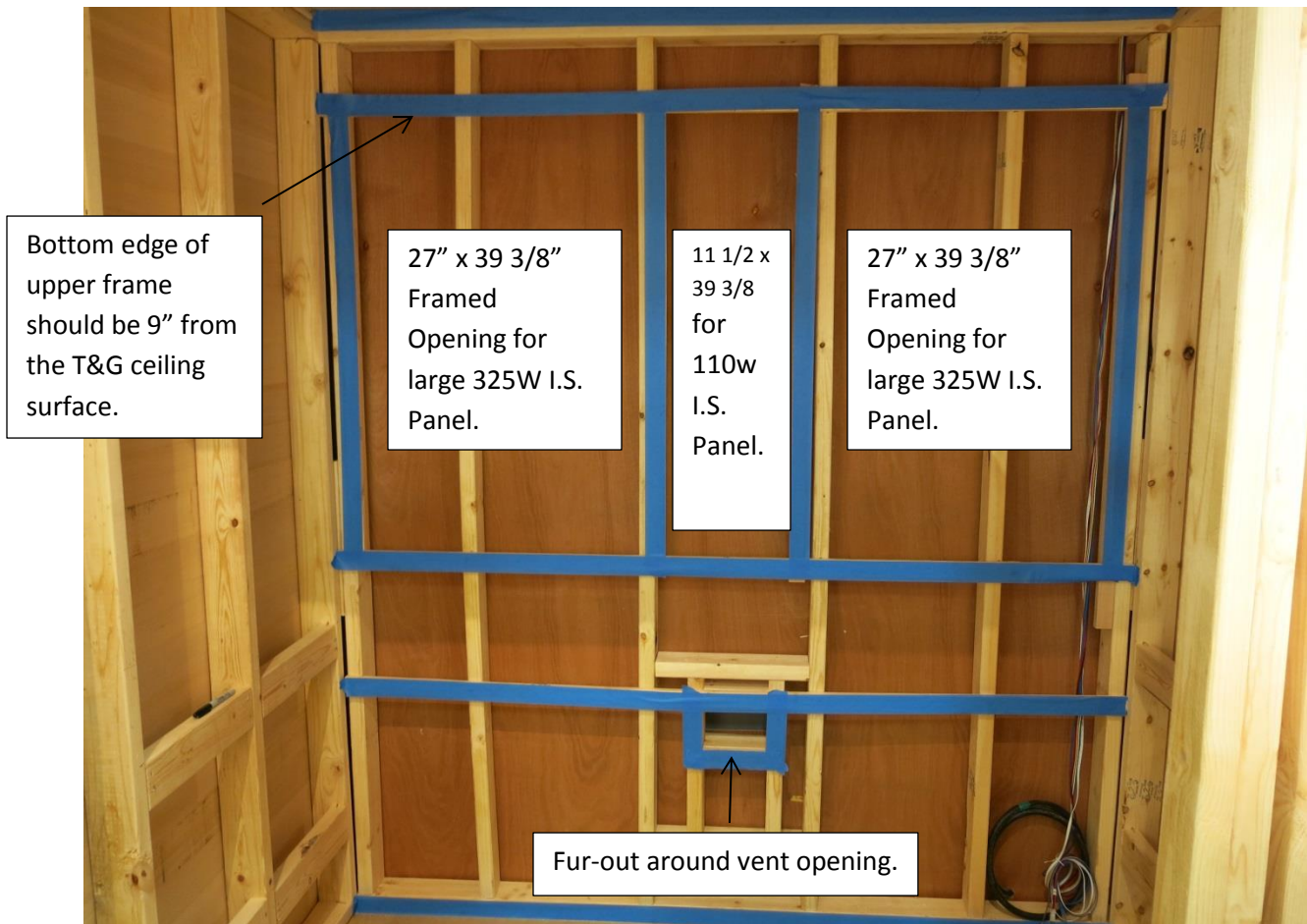

Photo A

After your ceiling has been covered with T&G, always start furring on your back wall. In this example, we will be installing 3 I.S. panels (two 325 watt and one 110 watt). The minimum distance to place your vertical framing from either corner is 2 3/4" from the framed stud face to the inside dimension of the furring strip. The small (110 watt) panel will fit in the center and in this case will meet the minimum spacing of 1/2" from the two larger panels. So, we were able to use a standard 1x2 to vertically frame between the 3 panels. If your back wall is wider than our example, you may wish to install additional vertical furring strips to create a larger gap between the elements.

After framing in your panel "window openings", apply furring strips to the top and bottom plate of the wall as well as approximately 24" from the floor. If you have a vent opening under the bench you will want to frame around that as well.

Some of your vertical furring strips that form the sides of the "window openings" may NOT land directly over an existing vertical stud. Adding a backer board to the back side of your horizontal furring strips will give you a solid surface to attach your vertical furring strips. To avoid cracking the wood, always pre-drill before using screws or use a pneumatic nail gun. See Photo B for details.

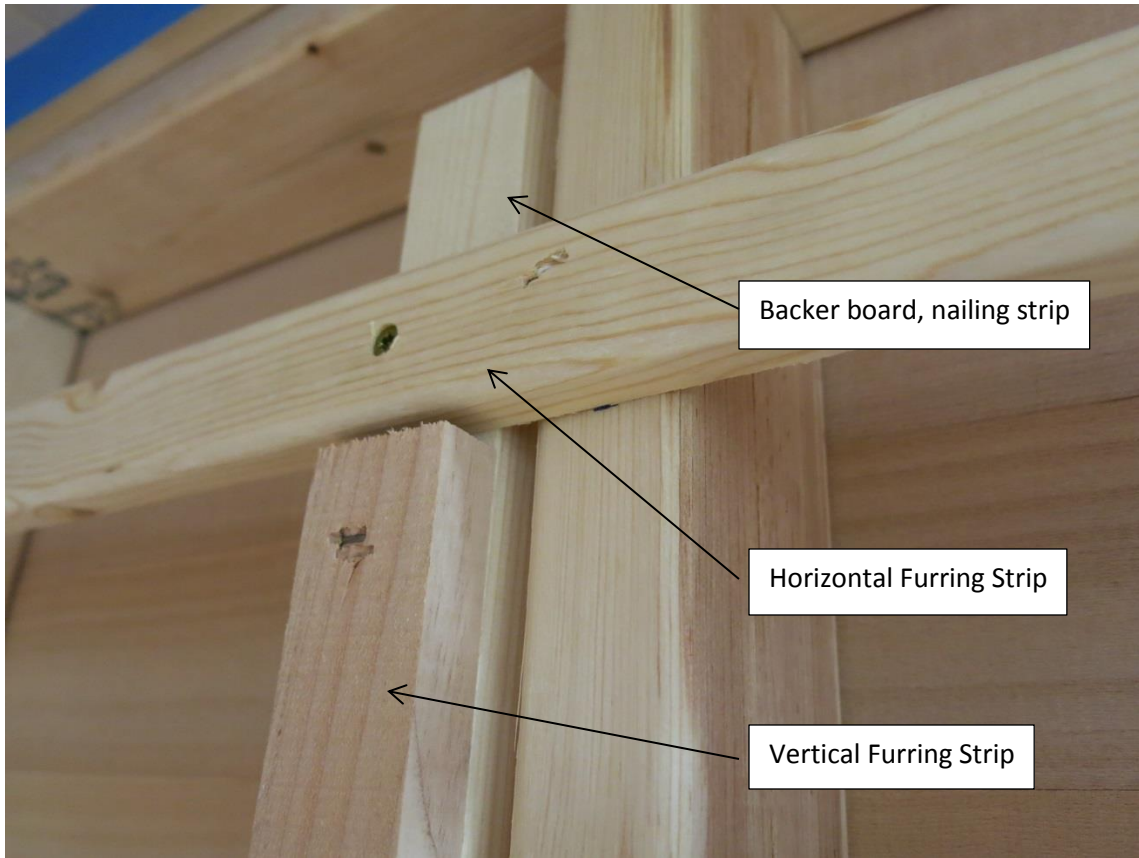

Photo B





Photo C

Before moving on any further, pre-fit your I.S. panels in your newly framed “window openings” to make sure they all fit with proper clearances between each panel and a minimum distance of at least 2” from the left/right wall corner studs or 1 ¼” from the furred out surface to the I.S. panel edge. See photos D & E below. If your panels do not meet this minimum, re-adjust your vertical furring strips to meet the minimum requirement.



Photo D



Photo E

The Left and Right side walls can now be furred-out. Again, starting 9" from the T&G ceiling surface install your first horizontal furring strip. Then, measure down 26 7/8" from the bottom edge of this strip and install your next horizontal furring strip. This will establish the top and bottom of your "window opening".

In our example, we will only have one I.S. panel on the left side wall but we still want to maintain our minimum distance from the corner of the back wall and left side wall. See photo's D & E on page 4.

Our right side wall will have one large 325 watt I.S. panel and one medium 160 watt I.S. panel. With keeping symmetry in mind, we used the same panel spacing as the back wall. This will give a nice, uniform flow from the right wall, back wall and left wall.

Also be mindful of bench support locations for the upper and lower benches as you will need to fur-out the surface of those support blocks too.

See photo F on page 6 for detailed view of the left side wall furring.



27" x 39 3/8" framed opening for large 325 watt I.S. Panel

Furring strips installed over bench supports

Photo F

Left Side Wall Detail





Photo G

Right Side wall detail

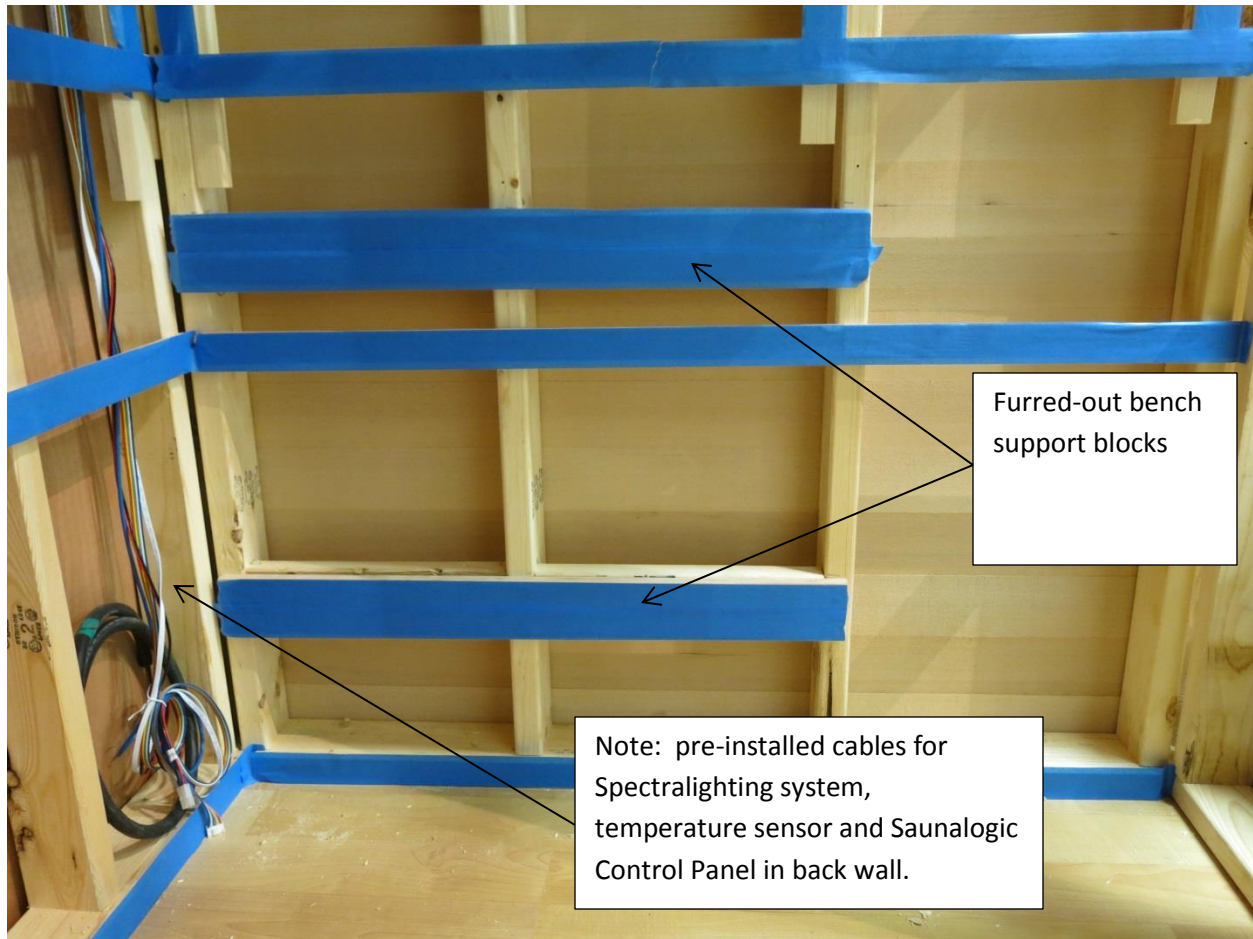

Photo H

#### Right Side Wall Detail

After pre-fitting all panels and double checking that all necessary surfaces are furred-out, you are ready to rough-in the electrical system to connect the I.S. panels to the CBPK contactor box.

In order to maintain the patented Low EMR/EMF qualities of these panels, you must use MC/BX (armored sheath with twisted, stranded conductors) to connect your individual panels. If you are not familiar with or are uncomfortable with installing this type of wiring, please consult with a qualified electrician. 12AWG MC/BX cable, Metallic Junction Boxes, bushings and cable clamps are not included with your kit.



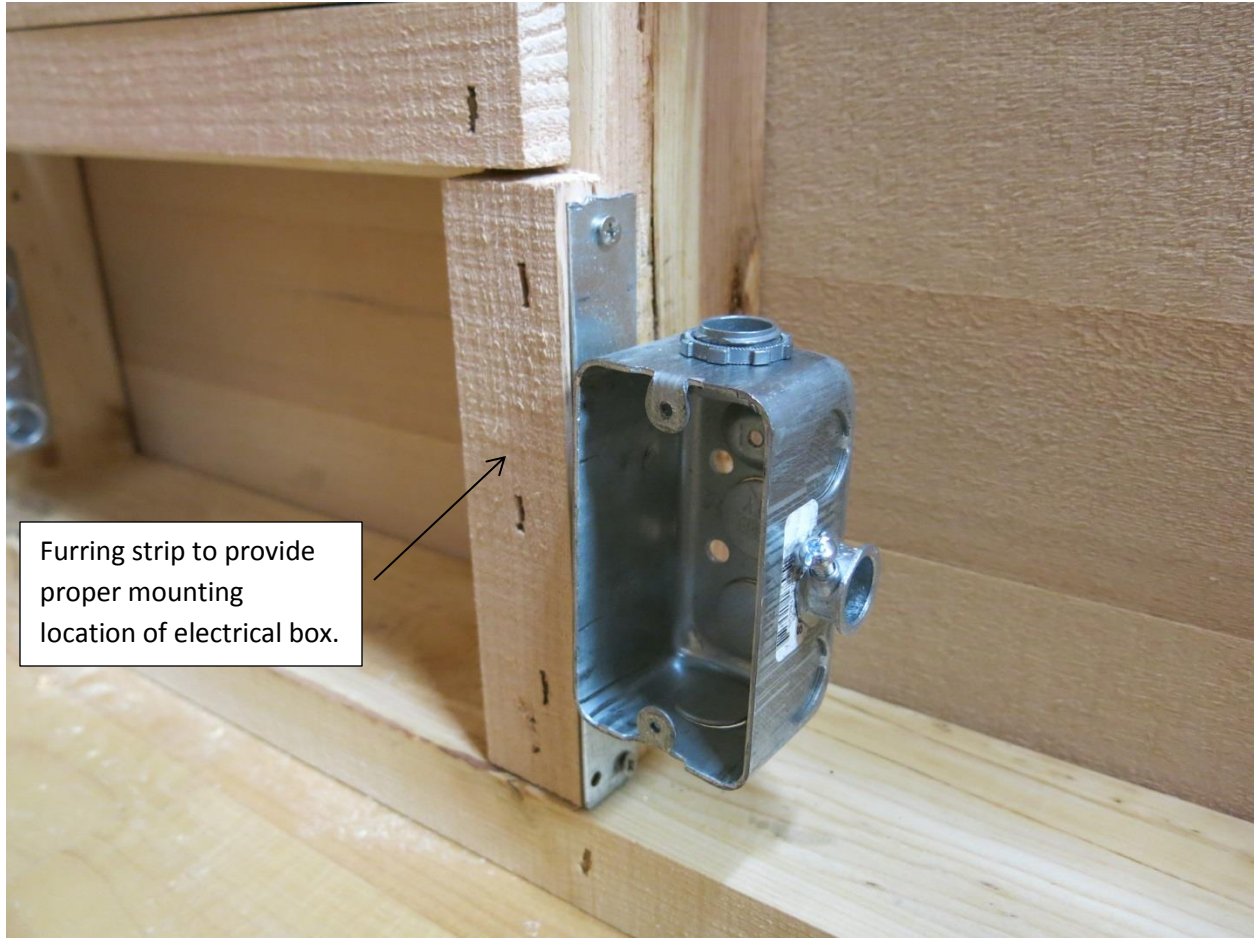

Photo I

Start by installing the metallic single-gang electrical boxes. Each panel is equipped with a built-in 1.5 meter service cable. This cable will be wired into it's own single-gang box that is typically located directly below each panel, just above the bottom plate of your framed room. Be sure to mount the electrical box so the open surface will be flush with our T&G surface. As shown in photo I, we had to add a furring strip to the face of the framing stud to get our electrical box to mount flush with finished T&G surface.



Photo J

Use a  $\frac{3}{4}$ " spade bit to drill holes between all of the single-gang boxes. Keep the holes at least 1" from the face of your framing so your T&G nails do not penetrate the MC/BX cable.



Photo K

Connect each box with the MC/BX cable. The idea here is to electrically connect each box in a “daisy-chain” fashion using a Parallel circuit.



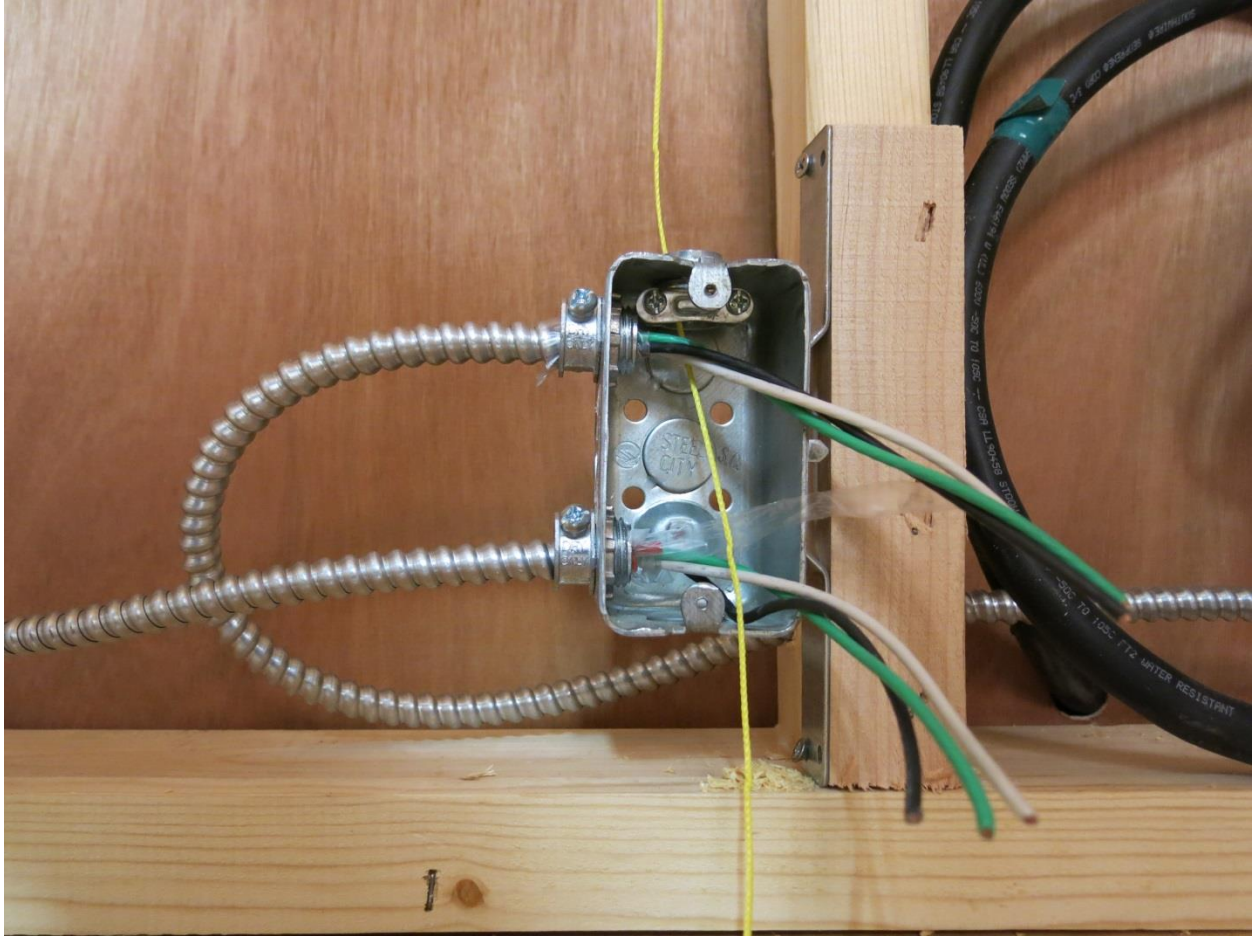

Photo L

Strip back about 8" of the MC/BX cable and insert into the single-gang box. Secure the cable with the appropriate cable clamps.



TIP: Add a pull string to the top of each box that runs up to the panel window opening!! For clarity, the photos are taken before insulating but it is recommended to do this step AFTER insulating.



Photo M

When you have completed your electrical rough-in and are satisfied that all framing is complete, it is time to add insulation to the walls. Standard R-13 un-faced fiberglass insulation is recommended. Spray-foam insulations are acceptable but must be open-cell and applied very carefully to avoid over-filling the wall cavities and distorting the framing.

Closed cell spray-foam insulation should be avoided in a sauna because it creates its own vapor barrier. When you add the foil vapor barrier it will create a “double” vapor barrier which can trap condensation in the walls.



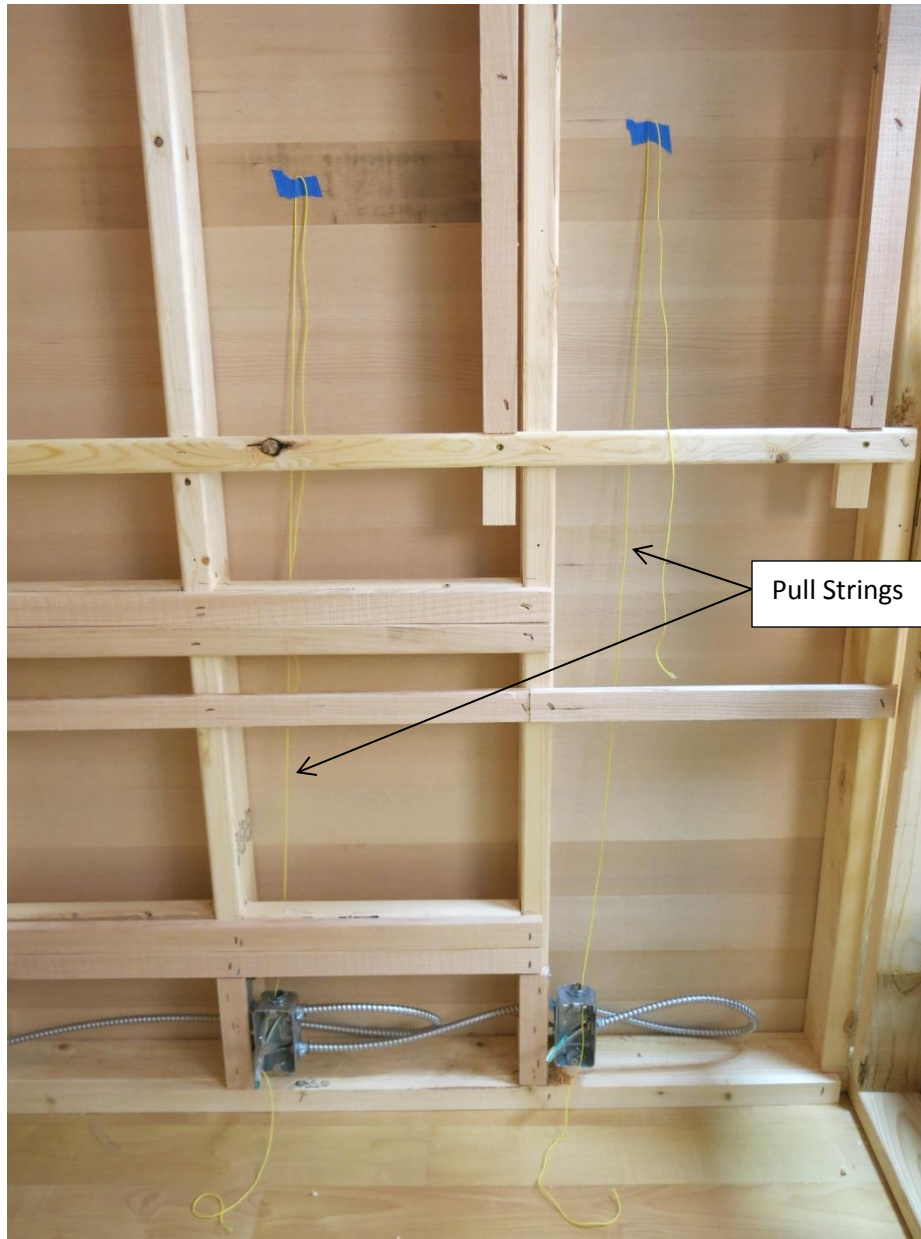

Photo N

After insulation is complete, install a “pull-string” from the top of each electrical box and extending into the “window-opening” for each I.S. panel. This will allow you to pull each I.S. panel service wire into the electrical box after the T&G and benches have been installed. Be generous with the string!

Note: For clarity, Photo N shows the pull strings installed without the insulation in the walls. Always add the pull strings directly after insulating! An alternate method is to run conduit from the top of the electrical box up to the “window-openings” for the I.S. panels.





Photo O

Attach your foil vapor barrier over the framed walls with the metallic side facing in to the sauna. The easiest method is to start at the bottom of the room and attach the vapor barrier horizontally with each row overlapping at least 6". A staple gun works best for attaching the vapor barrier but spray adhesive over the stud faces will also work.

Be sure to remove the vapor barrier at each I.S. panel "window-opening" (see photo O), all of the electrical boxes and the vent opening. Also, make sure the low voltage wires for lights and control are pulled out and not trapped behind the vapor barrier where they could accidentally get paneled over when the T&G is installed! See photo's on page 16 for details on vapor barrier installation.



Photo P



Photo Q



Photo R

As shown in photo's P – R, your foil vapor barrier will cover everything except the cut-outs for the I.S. panels, any electrical box locations, the air vent opening and any of the low voltage or electrical supply cables.

Your sauna is now ready to install the T&G wall paneling. Panel the back wall first then the two side walls and finally the front wall. Install your upper and lower bench supports and both benches.

Install the sauna door and any windows (if applicable). Finally, install the interior trim to all corners and door frame.

With help from a friend, attach each service wire from the back of the I.S. panels to the pre-installed pull strings with electrical tape. Tape on at least 12" of string to avoid having the string slip out while pulling the service wire down the wall cavity. Carefully pull the end of the string that is in the electrical box until the service wire is pulled into the electrical box opening. You will want at least 6" of service wire in the box, the extra wire can remain in the wall cavity. Avoid cutting the service wire to length as it is prepared at the factory for immediate installation.

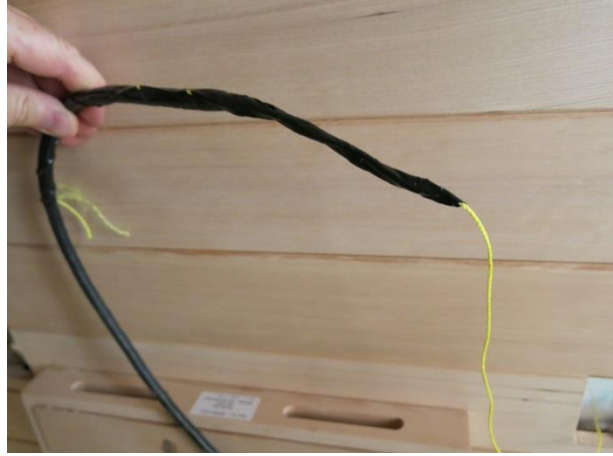

Photo S

To attach each I.S. Infra-red panel to the wall, insert the panel into the pre-framed “window-opening” with the service wire on the bottom portion of the panel. Use a level to align the panel and secure to the wall with a pneumatic pin nail gun or use 1 ¼” brad nails. It is recommend to only nail on the left and right vertical frame members. If using brad nails and a hammer, pre-drill each hole to avoid splitting the wood.

Fill in all nail heads with matching wood putty (natural pine) and sand smooth with 120 grit sand paper.





Attach pull string to your service wire. Tape a generous amount of string to avoid slipping out of wire.



Carefully pull service wire into the electrical box. Leave about 6-8" of cable exposed. Excess service wire can be left inside the wall cavity.



Tighten cable clamp and make electrical connections as shown.



Photo O

Cover each electrical box with a stainless steel blank plate.

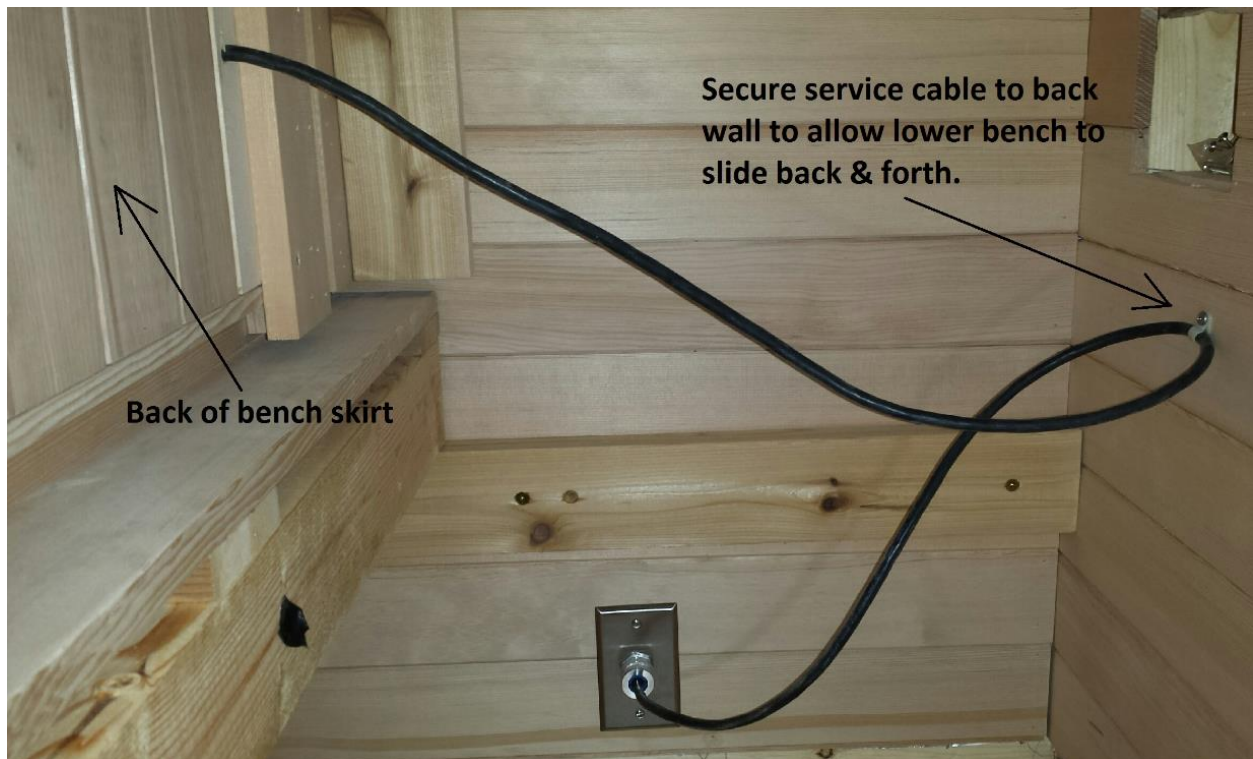

Photo P

Connect bench skirt wire to the closest electrical box using a seal-tight fitting. Secure slack in service wire to back wall so the lower bench is free to move back/forth for cleaning.



Photo P

Final connection to the CBPK-5 contactor box can be made by installing a MC/BX cable “whip” from the nearest IR panel junction box. This cable will go into the CBPK-5 box to connect to the output terminal block labeled **GND IR1 IR2**. See Drawings 4124-063 and 4124-065 for detailed wiring.



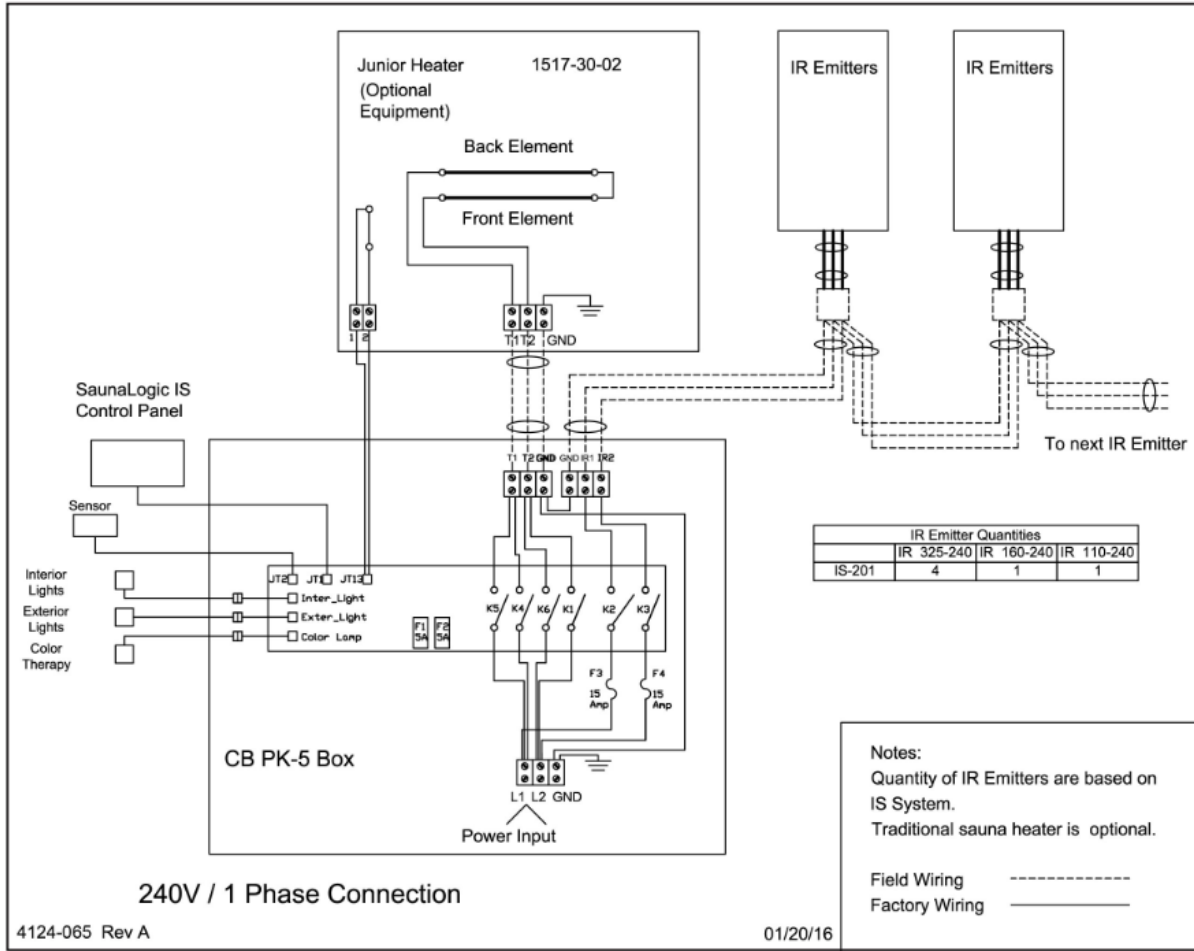

Dwg: 4124-065

Reference for kit model IS-201 only

Model	KW	Minimum Room size			Maximum Room			PHASE	VAC	IR Amps	Wire Size		*Optional Traditional Heater
		Floor Area	Ceiling Height	Volume Cu. Ft.	Ceiling Height	Volume Cu. Ft.	Power Supply to CB PK-5				CB PK-5 to Traditional Heater		
SI-201	1.6	12 sq. ft.	73 1/2"	100	96"	150	1	240	6.5	2 #12AWG + GR	2 #12AWG + GR	Junior 3.0	
IS-301	2	16 sq. ft.	73 1/2"	135	96"	200	1	240	8.3	2 #10AWG + GR	2 #10AWG + GR	Viki 4.5	
IS-401	2.3	21 sq. ft.	73 1/2"	175	96"	300	1	240	9.7	2 #10AWG + GR	2 #10AWG + GR	Viki 6.0	
IS-601	3	31 sq. ft.	73 1/2"	250	96"	425	1	240	12.4	2 #8AWG + GR	2 #8AWG + GR	Viki 8.0	

IS Kit Emitter Quantities

*Denotes an optional traditional sauna heater may be added to the System. Refer to Installation and Operation manual for installation instructions.  All installation and service to this equipment should be performed by qualified licensed personnel in accordance with local and national codes.	IR 325-240	IR 160-240	IR 110-240	
	IS-201	4	1	1
	IS-301	5	1	2
	IS-401	6	1	2
IS-601	8	1	2	

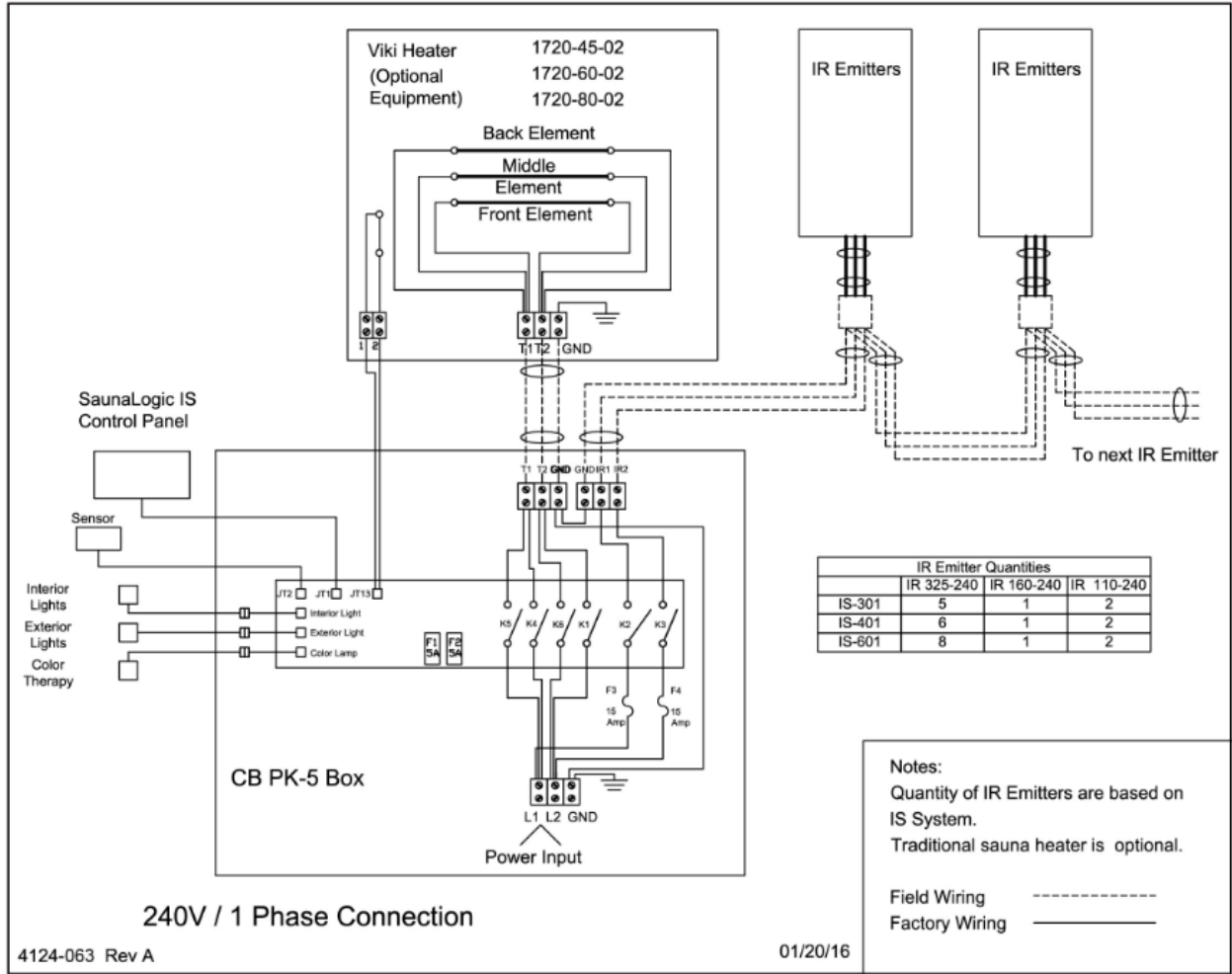

Dwg: 4124-063

Reference for kit models IS-301, IS-401 & IS-601 only

Model	KW	Minimum Room size			Maximum Room			PHASE	VAC	IR Amps	Wire Size		*Optional Traditional Heater
		Floor Area	Ceiling Height	Volume Cu. Ft.	Ceiling Height	Volume Cu. Ft.	Power Supply to CB PK-5				CB PK-5 to Traditional Heater		
SI-201	1.6	12 sq. ft.	73 1/2"	100	96"	150	1	240	6.5	2 #12AWG + GR	2 #12AWG + GR	Junior 3.0	
IS-301	2	16 sq. ft.	73 1/2"	135	96"	200	1	240	8.3	2 #10AWG + GR	2 #10AWG + GR	Viki 4.5	
IS-401	2.3	21 sq. ft.	73 1/2"	175	96"	300	1	240	9.7	2 #10AWG + GR	2 #10AWG + GR	Viki 6.0	
IS-601	3	31 sq. ft.	73 1/2"	250	96"	425	1	240	12.4	2 #8AWG + GR	2 #8AWG + GR	Viki 8.0	

\*Denotes an optional traditional sauna heater may be added to the System. Refer to Installation and Operation manual for installation instructions.

All installation and service to this equipment should be performed by qualified licensed personnel in accordance with local and national codes.

IS Kit Emitter Quantities

	IR 325-240	IR 160-240	IR 110-240
IS-201	4	1	1
IS-301	5	1	2
IS-401	6	1	2
IS-601	8	1	2

Recess Mount IR panel size and rough opening dimensions

<b>Recess Panel</b>	<b>Frame Width</b>	<b>Frame Height</b>	<b>Max R.O. Width</b>	<b>Max R.O. Height</b>
IR 325-240	28 ¼"	40"	27"	39 3/8"
IR 160-240	16"	40"	14 ¾"	39 3/8"
IR 110-240	12 ½"	40"	11 ½"	39 3/8"